

This Information Is Provided By
CBTricks.com

Teaberry Stalker XII Service Manual

Liability of damages to any equipment is the sole responsibility of the user! Downloading, viewing, or using any information provided on these pages automatically accepts the user to the terms of this agreement!

Modifications are provided for information purposes only!

Supporters of CBTricks.com paid for the hosting so you would have this file.

CBTricks.com is a non-commercial personal website was created to help promote the exchange of service, modification, technically oriented information, and historical information aimed at the Citizens Band, GMRS (CB "A" Band), MURS, Amateur Radios and RF Amps.

CBTricks.com is not sponsored by or connected to any Retailer, Radio, Antenna Manufacturer or Amp Manufacturer, or affiliated with any site links shown in the links database. The use of product or company names on my web site is not endorsement of that product or company.

The site is supported with donations from users, friends and selling of the Site Supporters DVD's to cover some of the costs of having this website on the Internet instead of relying on banner ads, pop-up ads, commercial links, etc. Thus I do not accept advertising banners or pop-up/pop-under advertising or other marketing/sales links or gimmicks on my website.

ALL the money from donations is used for CBTricks.com I didn't do all the work to make money (I have a day job). This work was not done for someone else to make money also, for example the ebay CD sellers.

All Trademarks, Logos, and Brand Names are the property of their respective owners.

This information is not provided by, or affiliated in any way with any radio or antenna Manufacturers.

Thank you for any support you can give.

For information on how to Support CBTricks.com

<http://www.cbtricks.com/support/>



STALKER XII

SERVICE MANUAL



\$5.00

Table of Contents

Page

2. Specifications
3. Alignment Power Supply and PLL
4. Alignment Transmitter
5. Alignment Receiver
6. Test Equipment Setup
7. Transistor Voltage Chart
8. IC Voltage Chart
9. PLL Programming Chart
10. TA 7310P
11. UPD 2816P
12. TM4801P
13. TA7222P
14. Clock Diagram
15. Wiring Diagram
16. Block Diagram
17. Semiconductor Pin Locations
20. PCB Bottom View
21. PC451AA Channel Selector PCB
22. PC541AA Clock PCB
23. PC410AC Power Supply PCB
24. PC398AA Jack PCB
25. Component Layout
26. Wiring Diagram
27. Schematic
28. PCB Parts Assembly
29. Parts List

Specifications

Power Source	117V AC/13.8V DC
Size	15" x 11½" x 4¾"

Receiver Section

Sensitivity	0.5 uV
Squelch Threshold	0.5 uV
Squelch Deepest Point	1000 uV
"S" Meter S-9	100 uV
Delta Tune	± 1.5 KHz
Maximum AF Output Power	5.0 W
AF Output Power/10% Distortion	4.0 W
Selectivity BW @ 6 dB Down	± 6 KHz
Adjacent Channel Rejection	- 60 dB
Image Rejection	- 80 dB
Speaker Impedance	8 Ohm

Transmitter Section

Modulation (Peak)	100%
Power Output	4.0 W
Emission Type AM	6A3
Hum and Noise (Better than)	- 60 dB
Frequency Tolerance	0.002%
Antenna Impedance	50 Ohm
Frequency Determining Method	PLL

Public Address

Output Power @ 10% Distortion	4.0 W
-------------------------------------	-------

Alignment Procedure

1. AC Power Supply

a. Equipment Required:

- DC Volt Meter

b. Procedure:

Place the DC/AC switch, S305 in AC position. Connect DC volt meter to terminal of the fuse holder, F301 and ground. Then connect AC plug to AC power source and adjust VR201 for 13.8V reading.

2. Phase-Locked-Loop

a. Equipment Required:

- DC Voltmeter
- Frequency Counter
- Oscilloscope

b. Procedure:

Step	Preset To	Connections	Adjustment
1.	RX, CH 19	oscilloscope to lead of R14	Adjust L23 for a max. reading.
2.	TX, CH 19	frequency counter to lead of R14	Adjust L21 for 10.2MHz \pm 100Hz reading.
3.	RX, CH 19	same as step 2	Check the frequency range of DELTA TUNE. (+ 400 to + 950Hz and - 400 to - 950Hz on each side)
4.	TX, CH 40	DC volt meter to lead of R71 and GND	Adjust L20 for 3.2 \pm 0.1V reading.
5.		same as step 4	Check whether the voltages are within 0.8 to 3.7V on all channels and both transmit and receive modes.
6.	RX, CH 19	oscilloscope to lead of R63	Adjust L19 for a max. reading. (approx. 0.12Vrms)
7.	RX, CH 19	oscilloscope to lead of R10	Adjust L18 for a max. reading. (approx. 0.2Vrms)
8.	RX, CH 40	frequency counter to lead of R10	Check whether the frequency is within 16.710MHz \pm 0.5KHz.

3. Transmitter

a. Equipment Required:

- AF oscillator
- AF VTVM
- RF VTVM
- RF power meter
- 50ohm load and attenuator
- oscilloscope
- spectrum analyzer

b. Procedure:

Should set the controls as follows:

MIKE GAIN: max. C.W.
 CH 9/OFF: off
 PA/CB: CB
 MOD/SWR/CAL: MOD

Step	Preset To	Connections	Adjustment
1.	CH 19, no mod.	oscilloscope to lead of R54	Adjust L24 and L25 for a max. reading.
2.	CH 19, 80 - 100% mod. (1KHz)	see TX setup drawing	Adjust L17 and L13 for a max. reading on RF power meter.
3.	CH 19, no mod.	see TX setup drawing	Adjust L13 for 4 watts reading on RF power meter.
4.	same as step 3	see TX setup drawing	Adjust L10 for a min. 2nd harmonic on spectrum analyzer.
5.	CH 19, 1KHz 40mV on AF VTVM	see TX setup drawing	Adjust VR6 for 100% mod. on oscilloscope.
6.	same as step 5	see TX setup drawing	Adjust VR5 for a "100%" position on the transceiver's meter.
7.	same as step 5	see TX setup drawing	Check whether the RF power meter reading is increase modulation.
8.	CH 19, no. mod.	see TX setup drawing	Adjust VR 4 for "4w" position on the transceiver's meter.

4. Receiver

a. Equipment Required:

- RF signal generator
- AF VTVM
- Oscilloscope
- 8ohm load, resistive

b. Procedure:

Should set the controls as follows before proceeding:

CH 9/OFF: off

PA/CB: CB

NB switch: off

MOD/CAL/SWR: MOD.

DELTA TUNE: center

RF GAIN: max. C.W.

SQUELCH: max. C.C.W.

TONE: max. C.W.

SG Output Frequency: 27.185MHz

Step	Preset To	Adjustment
1.	CH 19, vol.: max. C.W.	Adjust L8, 7, 6, 5, 4, 3, 2 and L1 for a max. reading on AF VTVM.
2.	same as step 1	Adjust VR1 for 2V reading on AF VTVM with – 2dB output level of SG.
3.	same as step 1	Adjust VR2 for “S-9” position on the transceiver’s meter with 46dB SG level.
4.	CH 19, vol.: max. C.W. and SQ: max. C.W.	Adjust VR3 for 2V on AF VTVM with 66dB SG level.

SETUP DRAWINGS

PLL SETUP

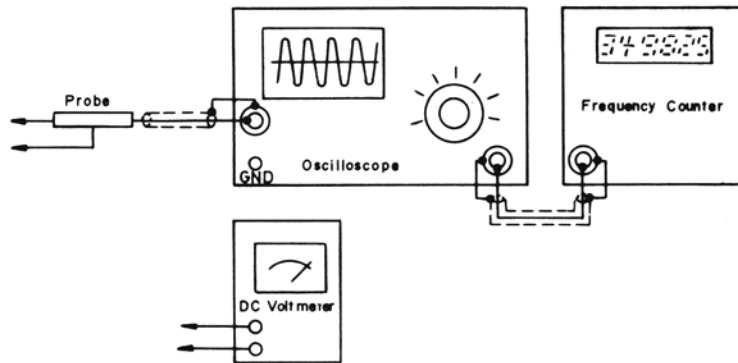

RX SETUP

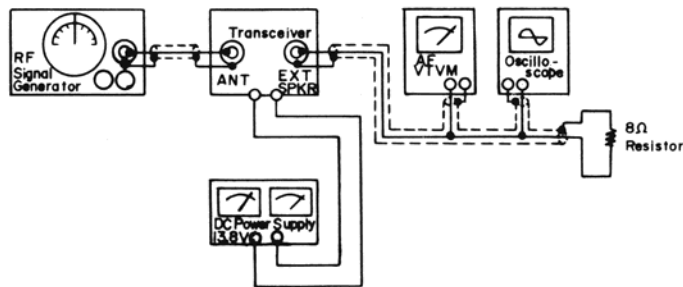

TX SETUP

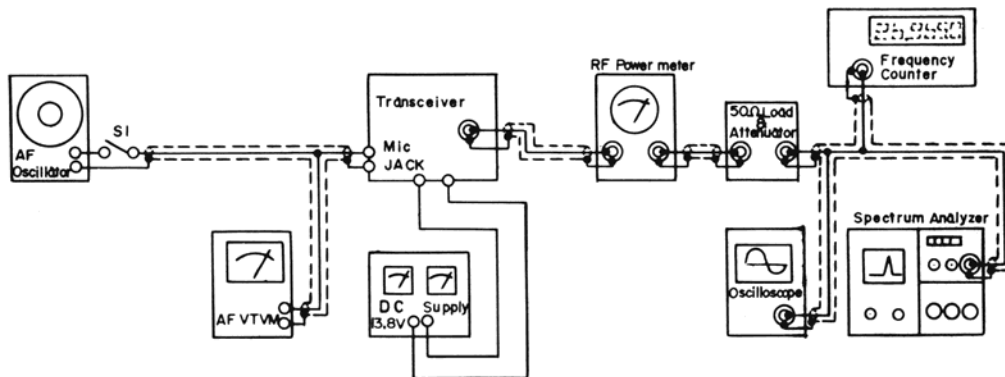

STALKER XII VOLTAGE CHART

Condition, RX: No Signal
TX: No Modulation.

	TX			RX			PA			Remarks
	B	C	E	B	C	E	B	C	E	
TR 1	0	1.1	0	0.6	0.1	0	3.4	1.3	0	
2	0.4	0.2	0	1.7	8.4	0.9	0	0.2	0	
3	G 0	D 0.2	S 0.2	G 0	D 8.5	S 3.4	G 0	D 0.2	S 0.2	
4	G 0	D 0.2	S 0.2	G 0	D 8.6	S 1.3	G 0	D 0.2	S 0.2	
5	0	0.2	0	1.4	8.1	0.8	0.2	0.2	0	
6	0	0.2	0	0.7	2.3	0	0	0.2	0	
7	0	13.3	0.2	2.3	13.0	1.6	0.2	13.7	0	
8	0.2	4.2	0	0.7 0	0 4.3	0 0	0.2	4.3	0	SQ off SQ on
9	0	0.2	0	0 0.6	0.7 0	0 0	0	0.2	0	SQ off SQ on
10	*	12.3	0	*	13.5	0	*	13.4	0	
11	*	12.0	0	*	13.5	0	*	13.4	0	
12	0.6	12.3	0.5	0.7	13.5	0.1	0.2	-0.6	0	
13	0.6	0	0	0 0.6	0	0	0.6	0	0	SQ off SQ on
14	5.4	7.6	4.9	5.5	7.6	4.9	5.4	7.6	4.9	
15	1.3	4.2	0.7	0	0	1.5	1.3	4.1	0.7	
16	0	0	0	0	0	0	0	0	0	
17	7.1	7.8	7.9	8.5	0	7.9	7.1	7.8	7.9	
18	8.5	12.6	7.9	8.5	12.6	7.9	8.5	11.9	7.9	
21				G 0 0	D 0 7.9	S 0 0.9				NB off NB on
22				3.5	7.9	3.0				NB off/on
23				0.5	6.8	0				NB off/on
24				0 7.8	0 0	0 7.9				NB off NB on
201	4.3	22.3	13.6	14.3	22.3	13.6	14.3	22.3	13.6	
202	14.8	22.3	14.3	14.8	22.3	14.3	14.8	22.3	14.3	
203	7.9	14.8	7.9	7.9	14.8	7.2	7.9	14.8	7.2	
701				0.3 0.7	14.8 0	0 0				Auto Power on Auto Power off

* Unable to measure DC voltage in actual operation.

STALKER XII VOLTAGE CHART

IC-1 pin #	1	2	3	4	5	6	7	8	9	10
	13.3	2.8	NC	0	1.8	1.8	0	0	6.7	13.0

IC-2 pin #	1	2	3	4	5	6	7	8	9
	2.7	2.0	1.5	2.5	0	4.2	0	4.7	1.2

IC-3 pin #	1	2	3	4	5	6	7	8	9
TX	2.6	2.1	1.2	2.4	0	7.7	2.1	7.7	7.7
RX	0	0	0	0	0	0	0	0	0

IC-4 pin #	1	2	3	4	5	6	7	8	9	10	11	12	13	14	15
TX	See program chart of BCD code.						4.7	4.7	0.6	1.7	4.7	2.3	2.3	2.3	4.6
RX	See program chart of BCD code.						4.7	4.7	4.7	1.7	4.7	2.3	2.3	2.3	4.6

pin #	16	17	18	19	20	21	22
TX	4.7	1.5	1.5	1.8	0	0	2.3
RX	4.7	1.5	1.5	2.7	0	0	2.3

IC-701 pin #	31	33	35	36	37
	16.0	13.8	13.8	13.8	10.0

Program Chart of BCD Code

1st IF 10.695 (MHz)

2nd OSC 10.240 (MHz)

CH	Frequency (MHz)	TX			RX			Program					
		Divide Ratio (N)	P.I. Freq. (KHz)	VCO. Freq. (MHz)	Divide Ratio (N)	P.I. Freq. (KHz)	VCO. Freq. (MHz)	Input Level					
								P ₆	P ₅	P ₄	P ₃	P ₂	P ₁
1	26.965	273	1365	16.725	182	910	16.27	L	L	L	L	L	H
2	26.975	275	1375	16.735	184	920	16.28	L	L	L	L	H	L
3	26.985	277	1385	16.745	186	930	16.29	L	L	L	L	H	H
4	27.005	281	1405	16.765	190	950	16.31	L	L	L	H	L	L
5	27.015	283	1415	16.775	192	960	16.32	L	L	L	H	L	H
6	27.025	285	1425	16.785	194	970	16.33	L	L	L	H	H	L
7	27.035	287	1435	16.795	196	980	16.34	L	L	L	H	H	H
8	27.055	291	1455	16.815	200	1000	16.36	L	L	H	L	L	L
9	27.065	293	1465	16.825	202	1010	16.37	L	L	H	L	L	H
10	27.076	295	1475	16.835	204	1020	16.38	L	H	L	L	L	L
11	27.085	297	1485	16.845	206	1030	16.39	L	H	L	L	L	H
12	21.105	301	1505	16.865	210	1050	16.41	L	H	L	L	H	L
13	27.005	303	1515	16.875	212	1060	16.42	L	H	L	L	H	H
14	27.125	305	1525	16.885	214	1070	16.43	L	H	L	H	L	L
15	21.135	307	1535	16.895	216	1080	16.44	L	H	L	H	L	H
16	27.155	311	1555	16.915	220	1100	16.46	L	H	L	H	H	L
17	27.165	313	1565	16.925	222	1110	16.47	L	H	L	H	H	H
18	27.175	315	1575	16.935	224	1120	16.48	L	H	H	L	L	L
19	27.185	317	1585	16.945	226	1130	16.49	L	H	H	L	L	H
20	27.205	321	1605	16.965	230	1150	16.51	H	L	L	L	L	L
21	21.215	323	1615	16.975	232	1160	16.52	H	L	L	L	L	H
22	27.225	325	1625	16.985	234	1170	16.53	H	L	L	L	H	L
23	27.255	331	1655	17.075	240	1200	16.56	H	L	L	L	H	H
24	27.235	327	1635	16.995	236	1180	16.54	H	L	L	H	L	L
25	27.245	329	1645	17.005	238	1190	16.55	H	L	L	H	L	H
26	27.265	333	1665	17.025	242	1210	16.57	H	L	L	H	H	L
27	27.275	335	1675	17.035	244	1220	16.58	H	L	L	H	H	H
28	27.285	337	1685	17.045	246	1230	16.59	H	L	H	L	L	L
29	27.295	339	1695	17.055	248	1240	16.60	H	L	H	L	L	H
30	27.305	341	1705	17.065	250	1250	16.61	H	H	L	L	L	L
31	21.315	343	1715	17.075	252	1260	16.62	H	H	L	L	L	H
32	27.325	345	1725	17.085	254	1270	16.63	H	H	L	L	H	L
33	21.335	347	1735	17.095	256	1280	16.64	H	H	L	L	H	H
34	27.345	349	1745	17.105	258	1290	16.65	H	H	L	H	L	L
35	27.335	351	1755	17.115	260	1300	16.66	H	H	L	H	L	H
36	27.365	353	1765	17.125	262	1310	16.67	H	H	L	H	H	L
37	27.375	355	1775	17.135	264	1320	16.68	H	H	L	H	H	H
38	27.385	357	1785	17.145	266	1330	16.69	H	H	H	L	L	L
39	27.395	359	1795	17.155	268	1340	16.70	H	H	H	L	L	H
40	27.415	361	1805	17.165	270	1350	16.71	L	L	L	L	L	L

H: High Level (More than 3.5V DC)
L: Low Level (Less than 1.0V DC)

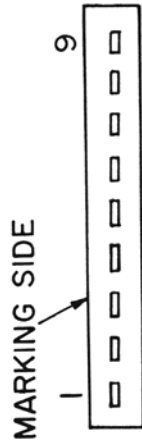

TA7310P

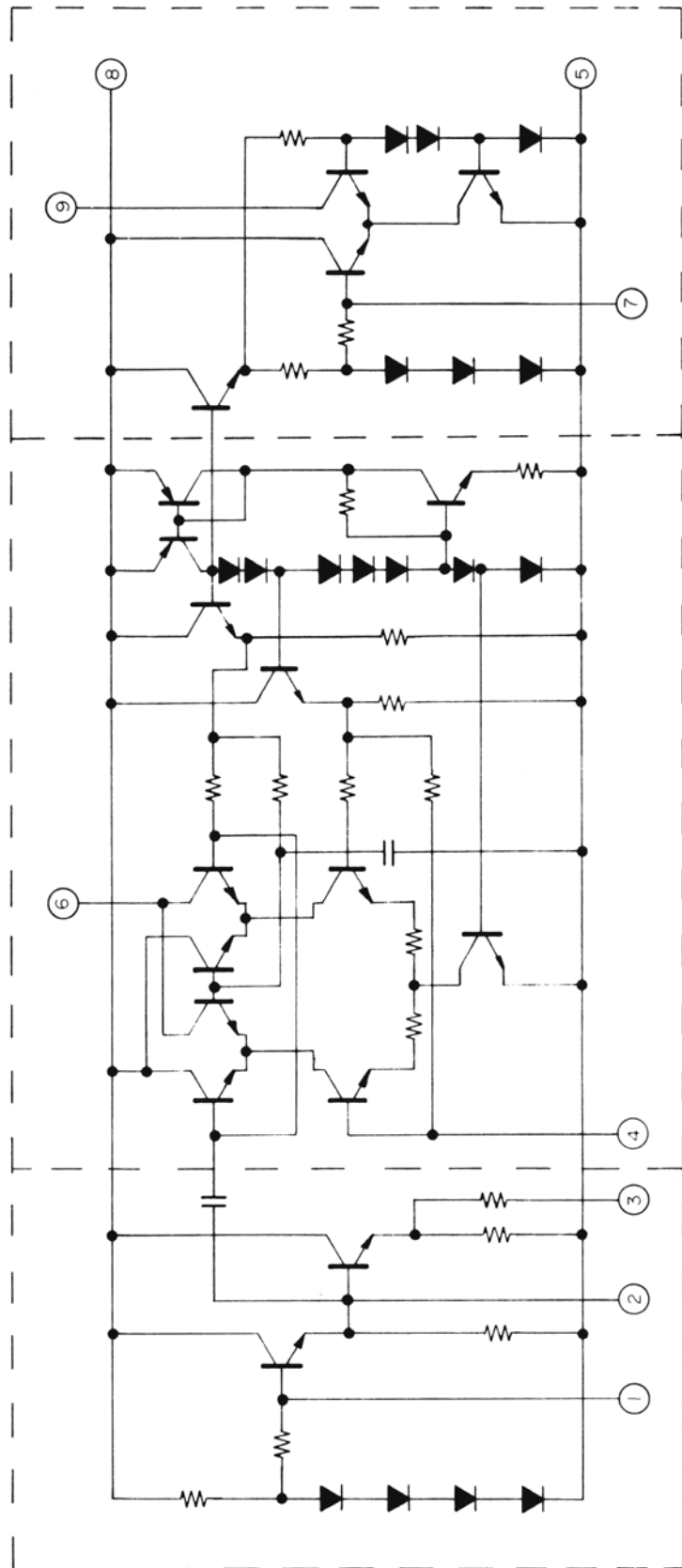

u PD2816C

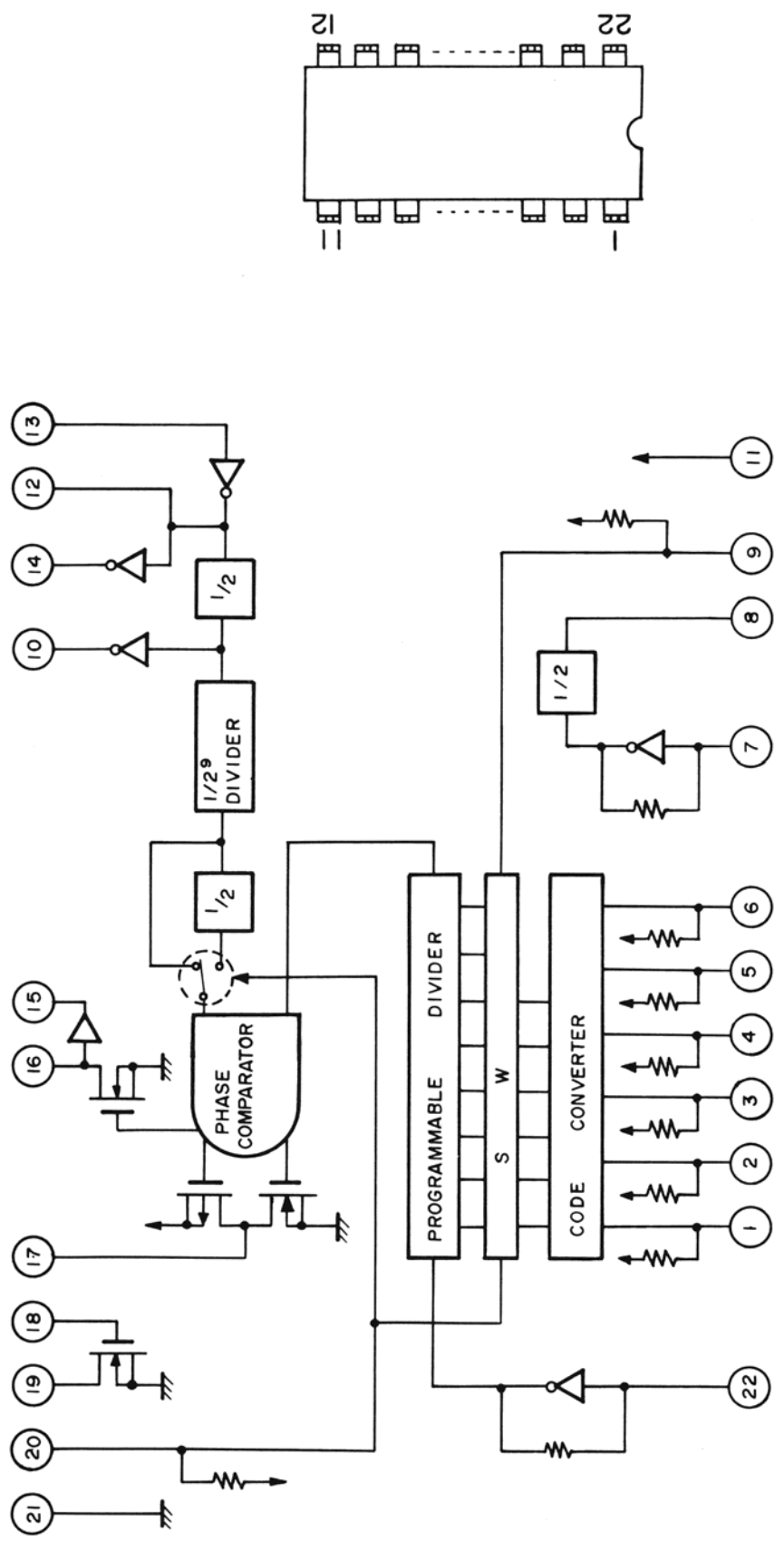

TM4801P

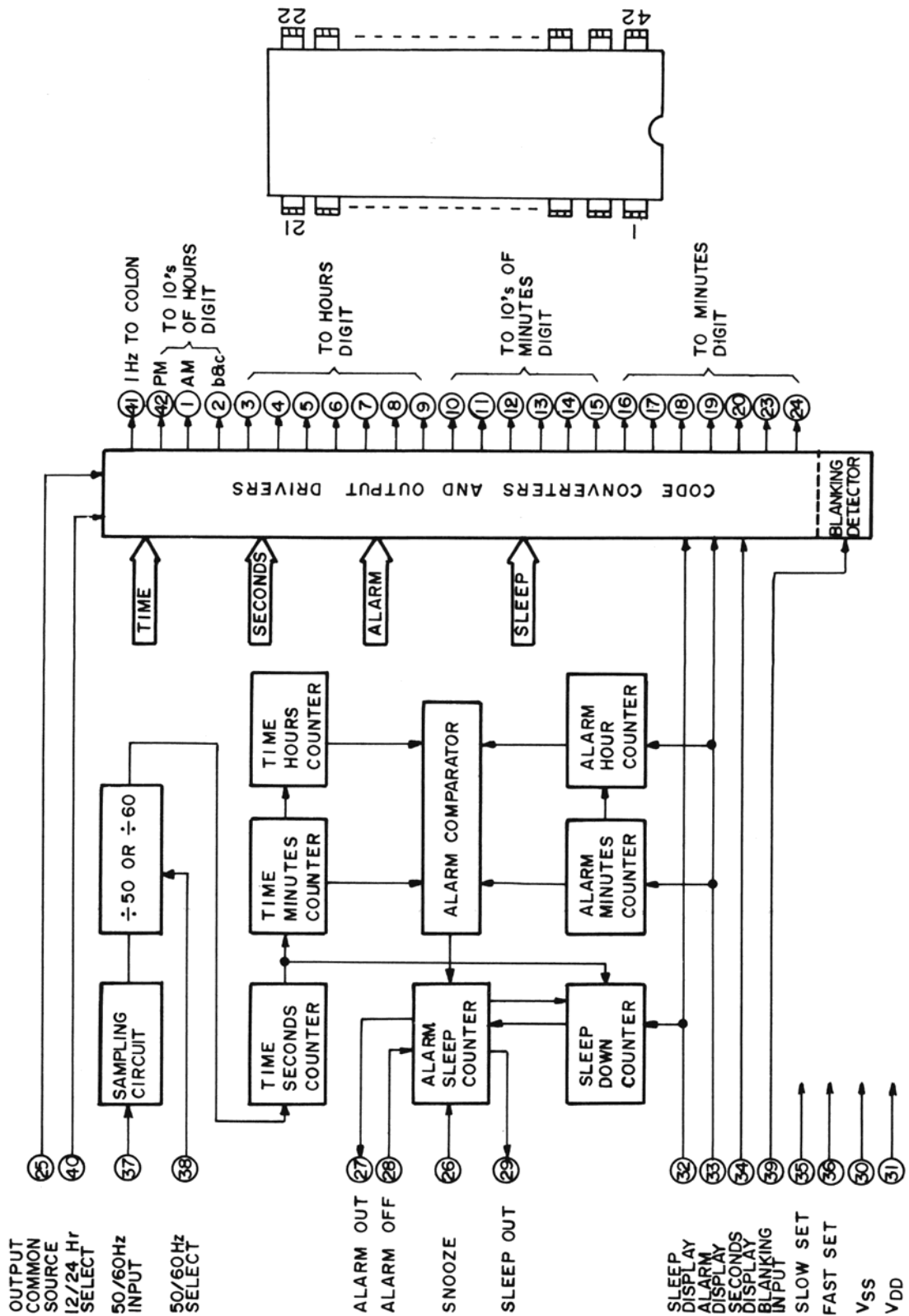

TA7222P

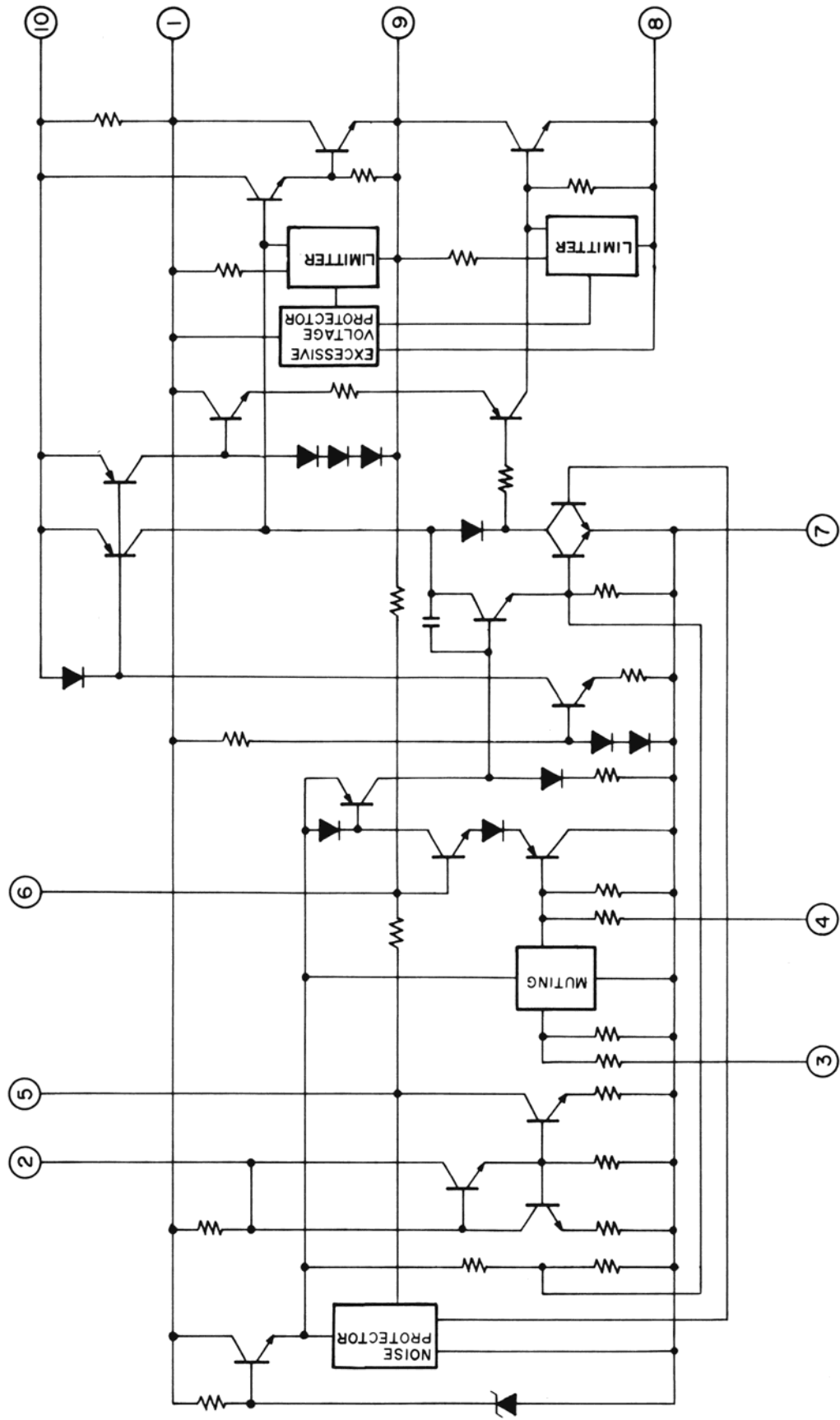

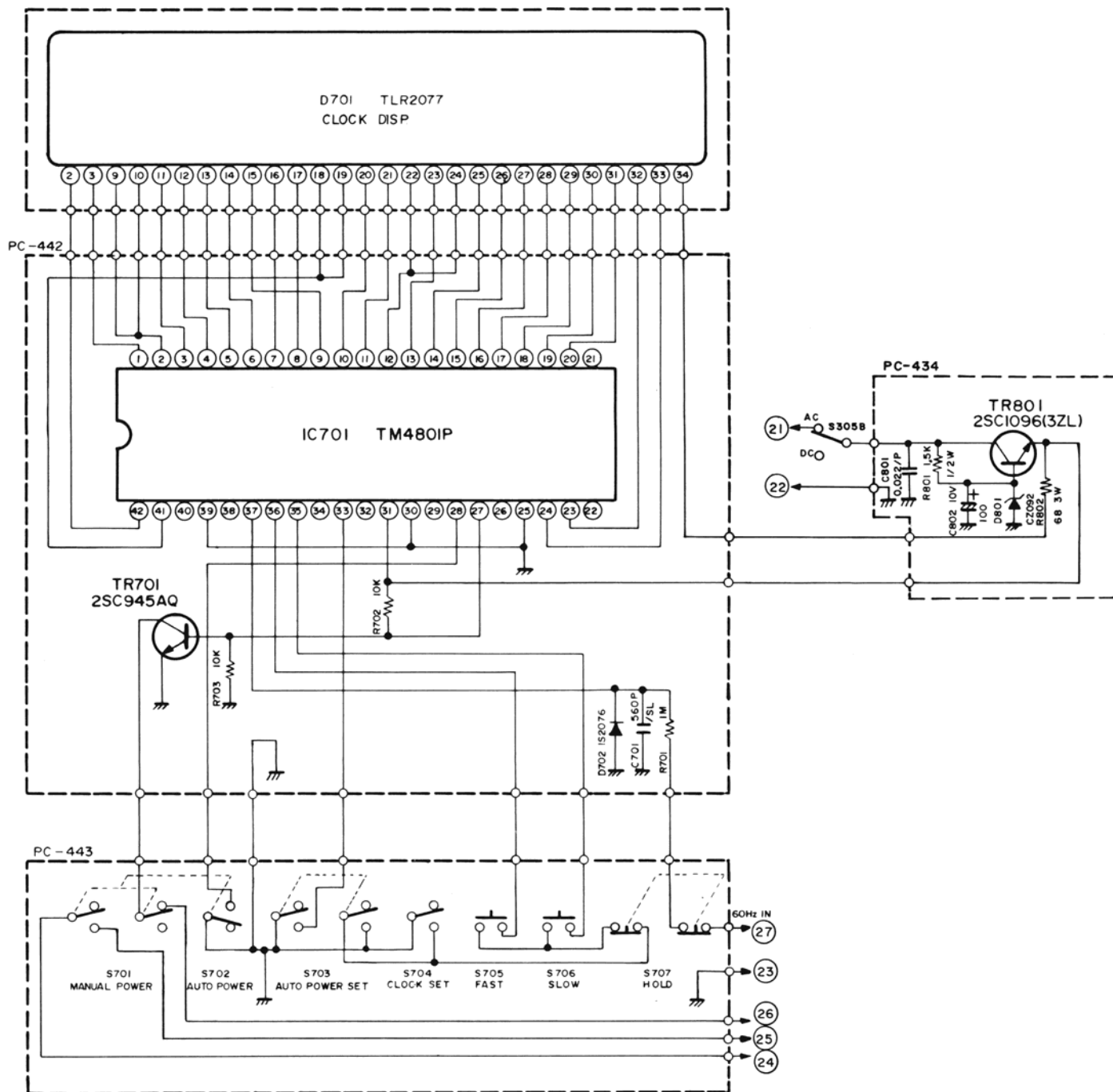

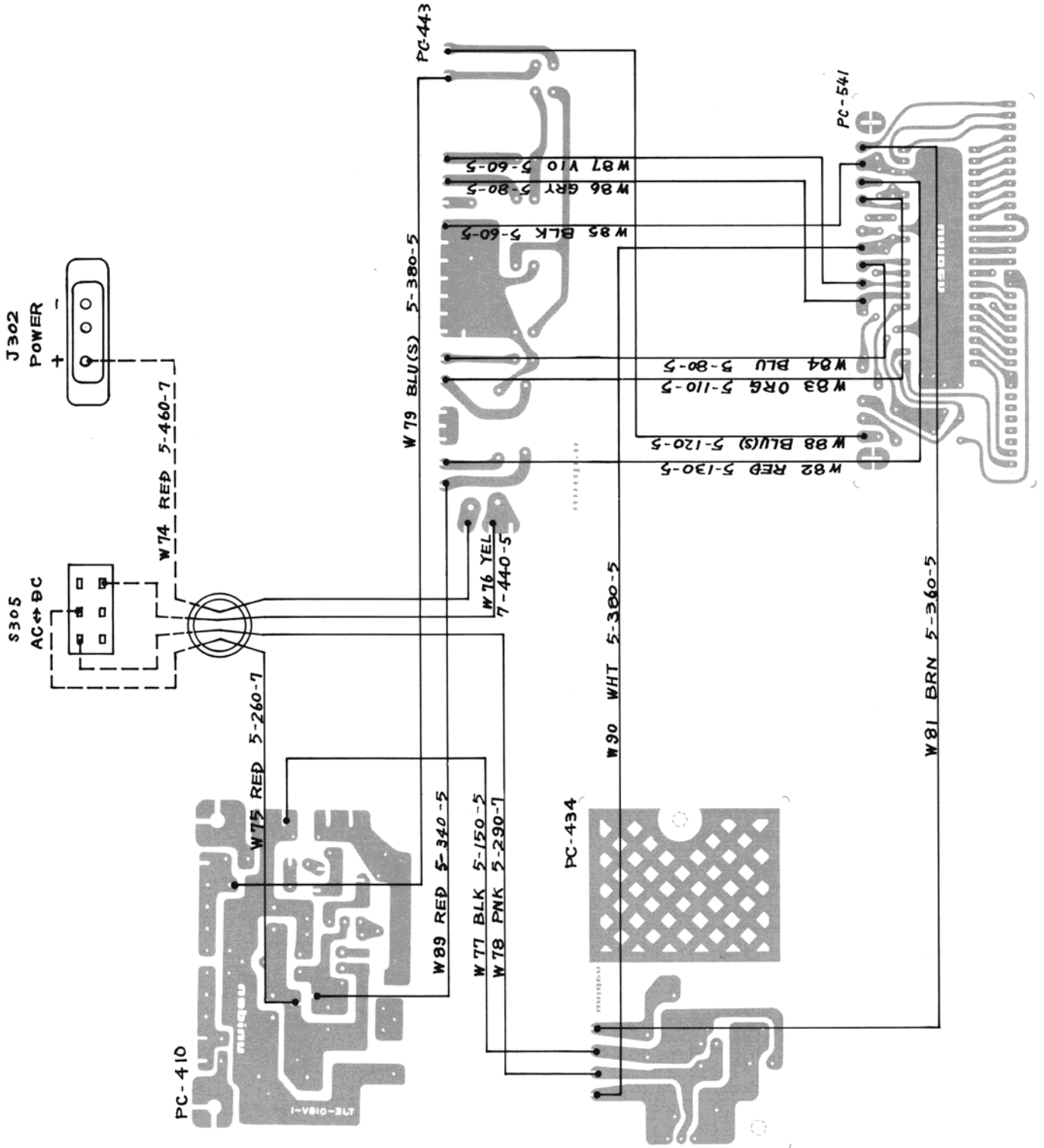

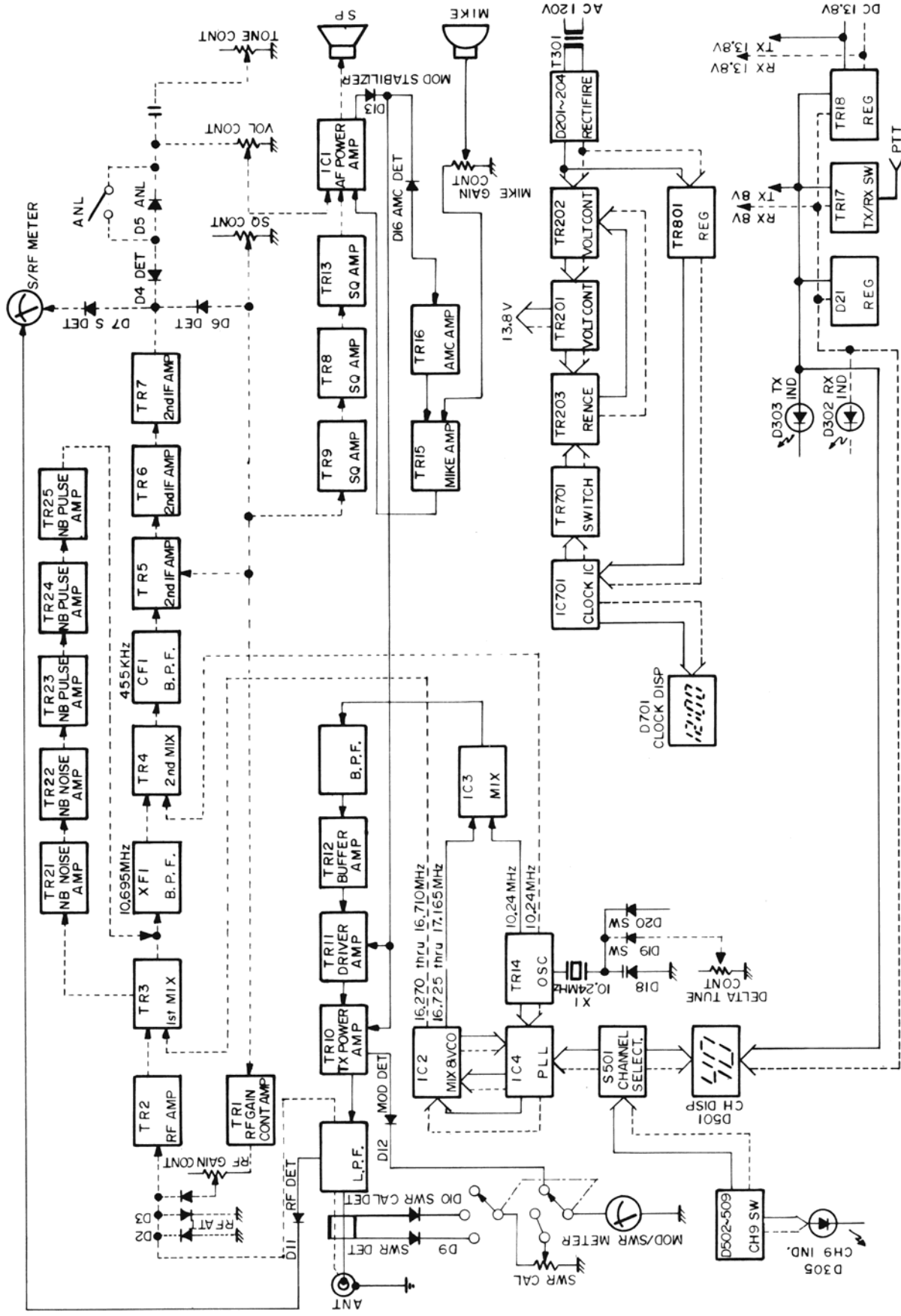

— SHOWS TX CIRCUIT
 - - - SHOWS RX CIRCUIT

TRANSISTOR

NOTE: B: BASE
E: EMITTER
C: COLLECTOR

MARKING
SIDE

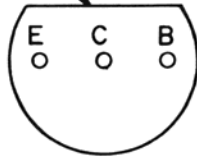

2SA733-P
2SC458-C
2SC945A-Q, P
2SC1674-L
2SC1675-L, M
2SC2076-C

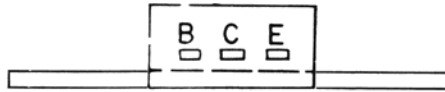

2SD586

MARKING
SIDE

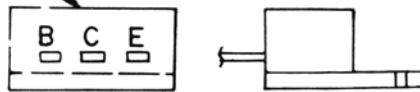

2SC2029-B/20, -B/10
2SC1096

MARKING
SIDE

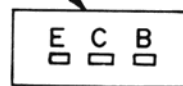

2SC2028-B/20

DIGIT 1 DIGIT 2

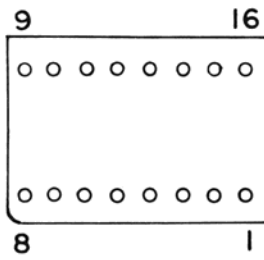
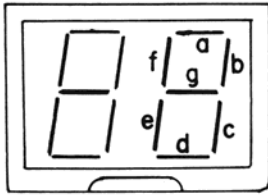

UR-202
(Anode Common)

Pin #		Pin #	
1	c-1	9	g-2
2	e-1	10	a-2
3	d-1	11	f-2
4	common-1	12	b-2
5	common-2	13	b-1
6	d-2	14	f-1
7	e-2	15	a-1
8	c-2	16	g-1

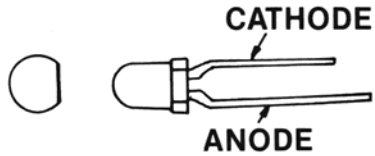

TLR-124
TLG-124A

FET

NOTE: D: DRAIN
S: SOURCE
G: GATE

MARKING
SIDE

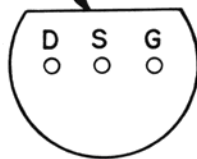

2SK104-H

MARKING
SIDE

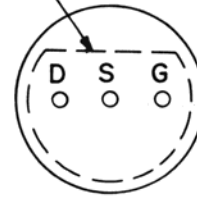

2SK19-BL, GR

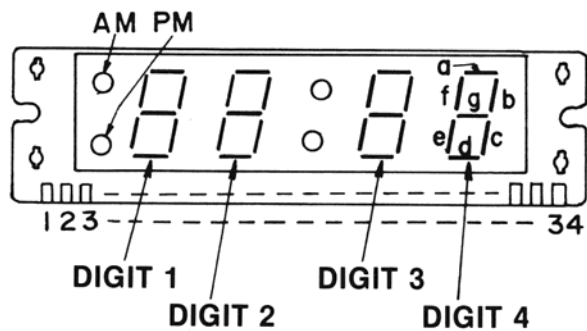

**TLR-2077
(Anode Common)**

Pin #		Pin #	
1	Common of all segments	18	upper colon
2	PM	19	lower colon
3	AM	20	f-3
4	NC	21	g-3
5	NC	22	a-3
6	NC	23	b-3
7	NC	24	d-3
8	NC	25	e-3
9	c-1	26	c-3
10	b-1	27	f-4
11	f-2	28	g-4
12	g-2	29	a-4
13	a-2	30	b-4
14	b-2	31	e-4
15	e-2	32	d-4
16	d-2	33	c-4
17	c-2	35	Common of all segments

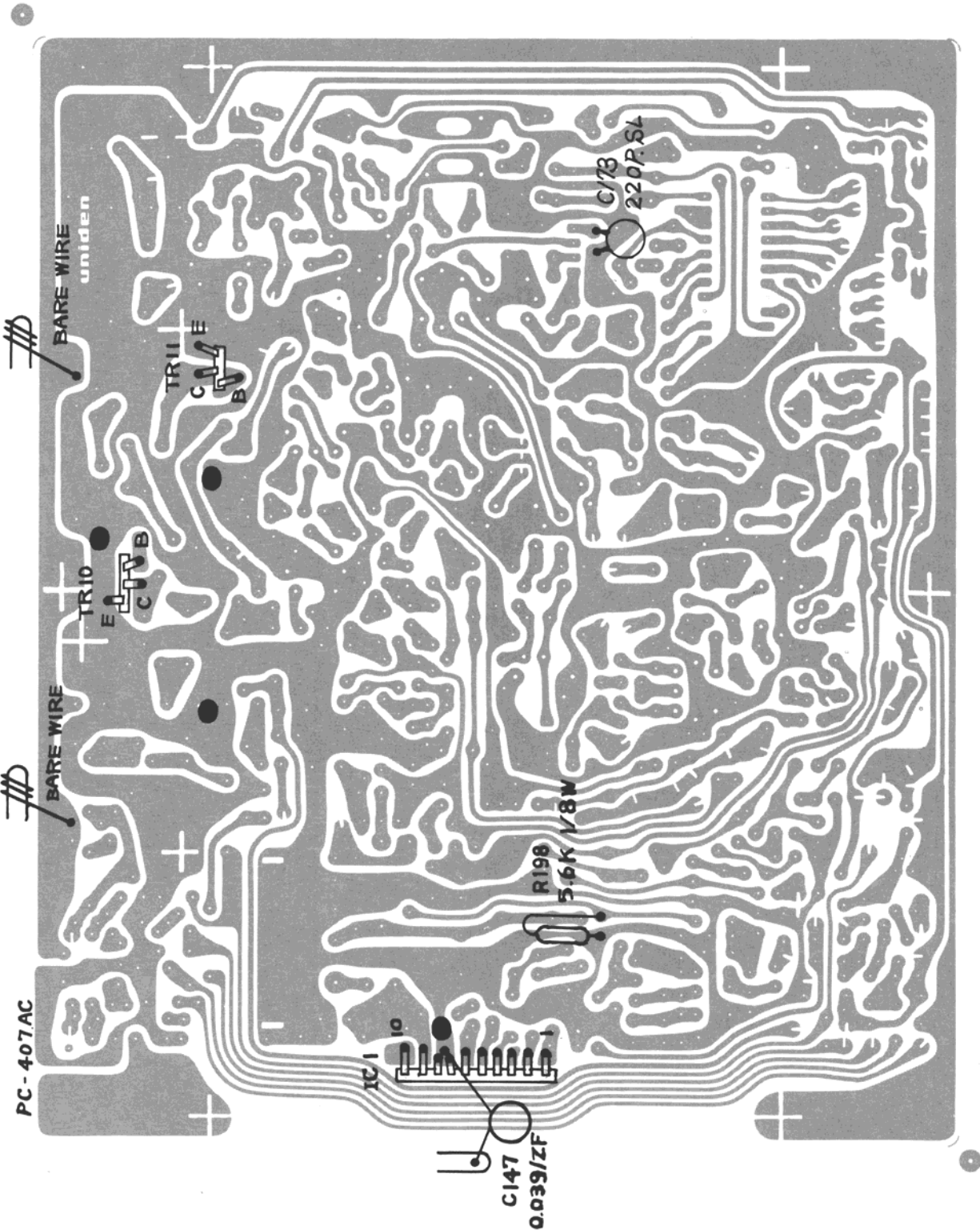

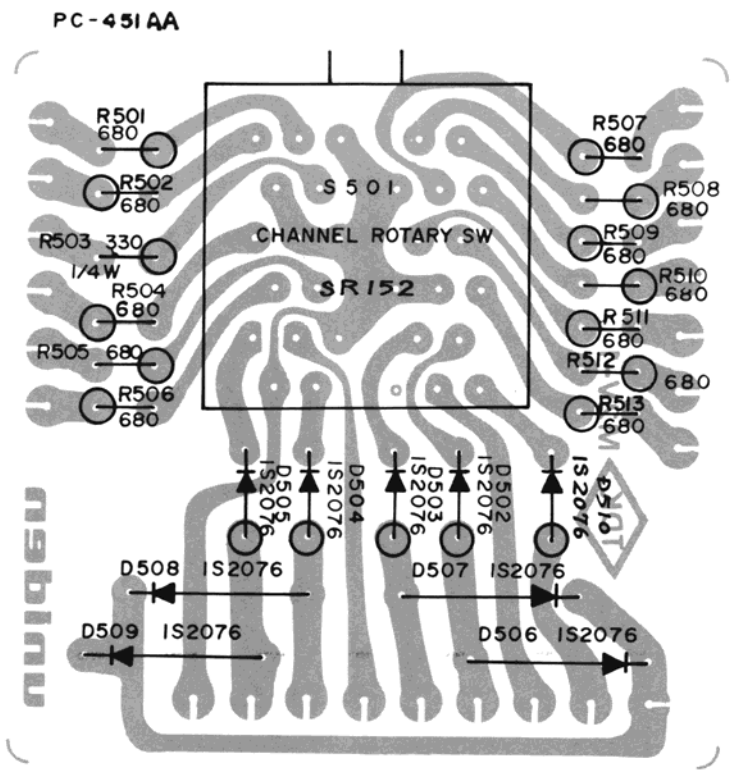

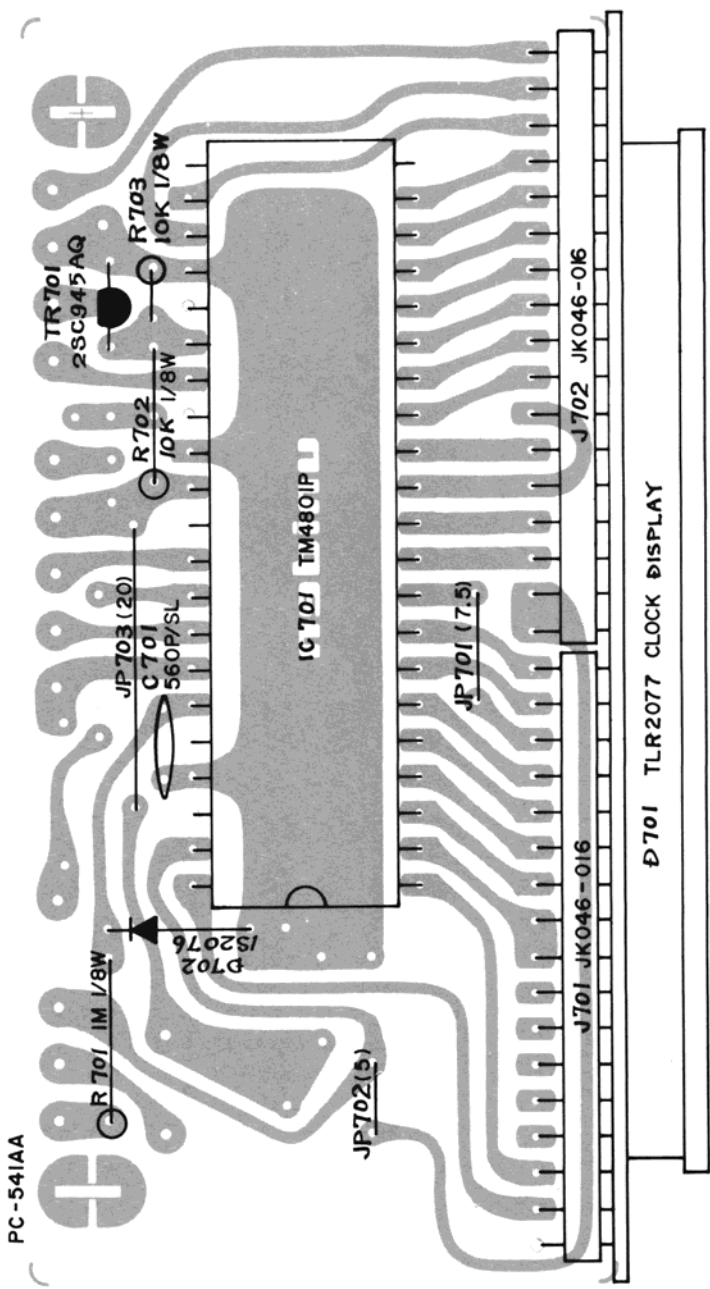

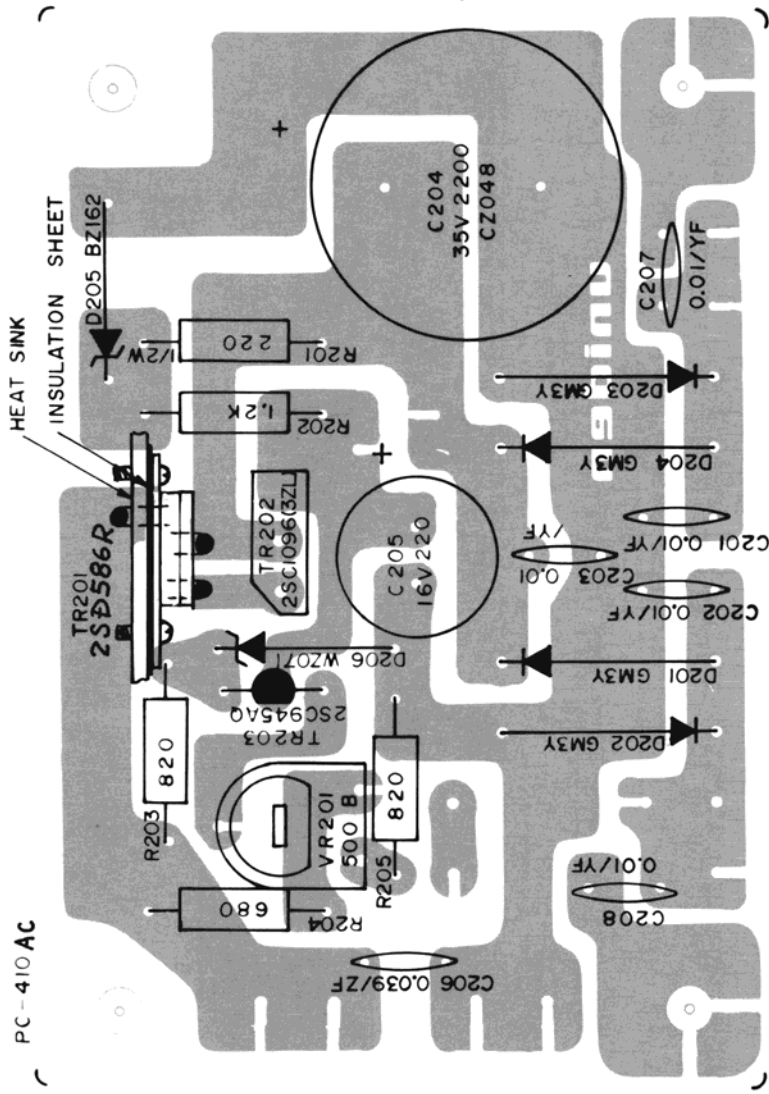

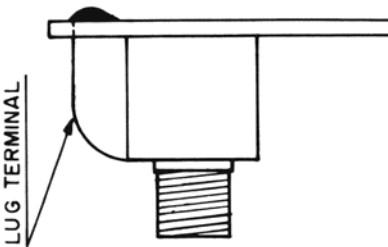
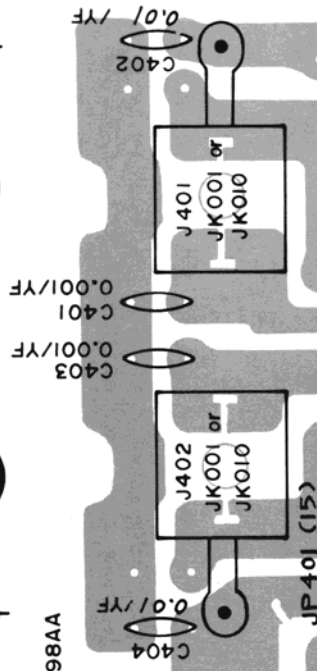
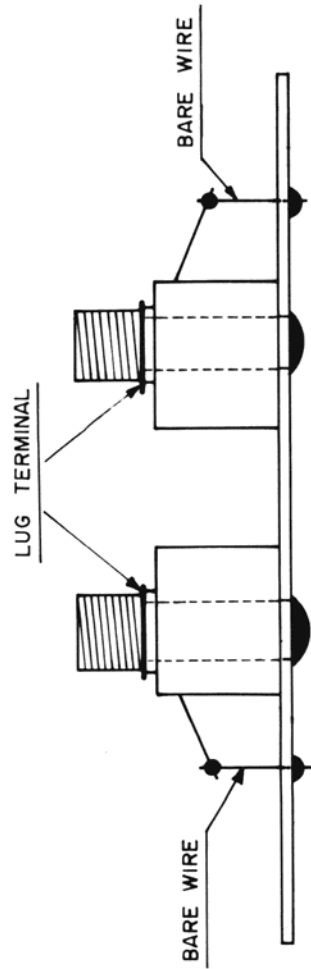

PC-398AA

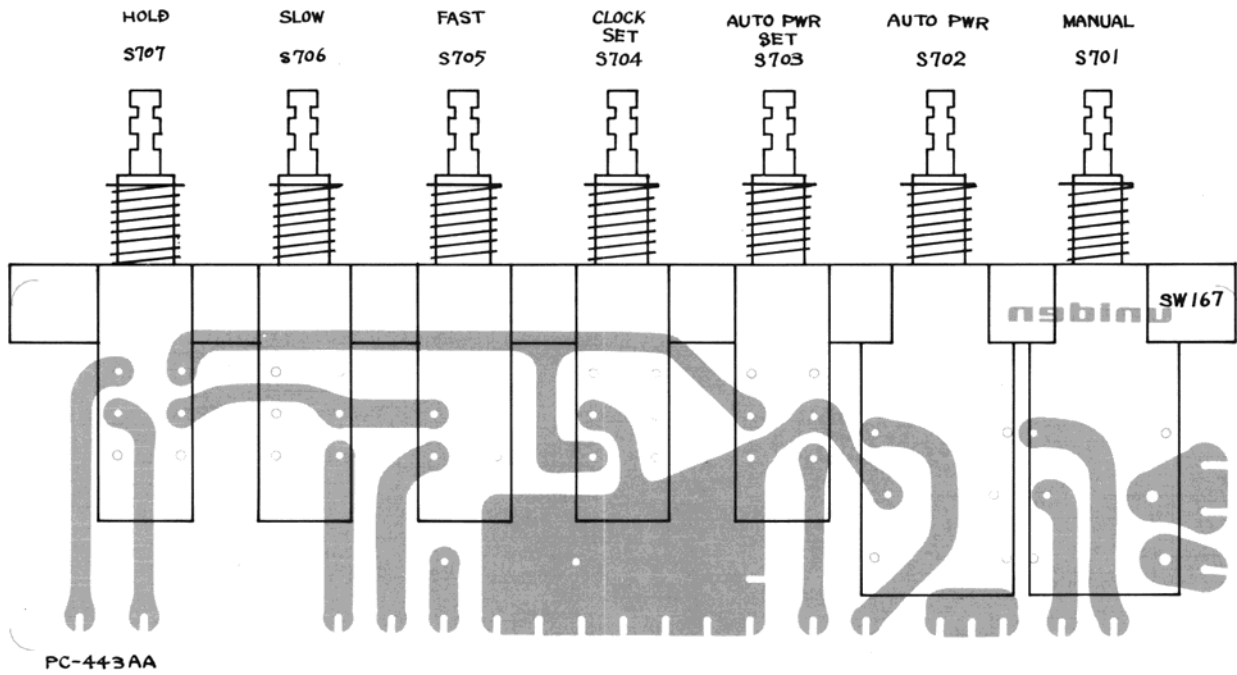
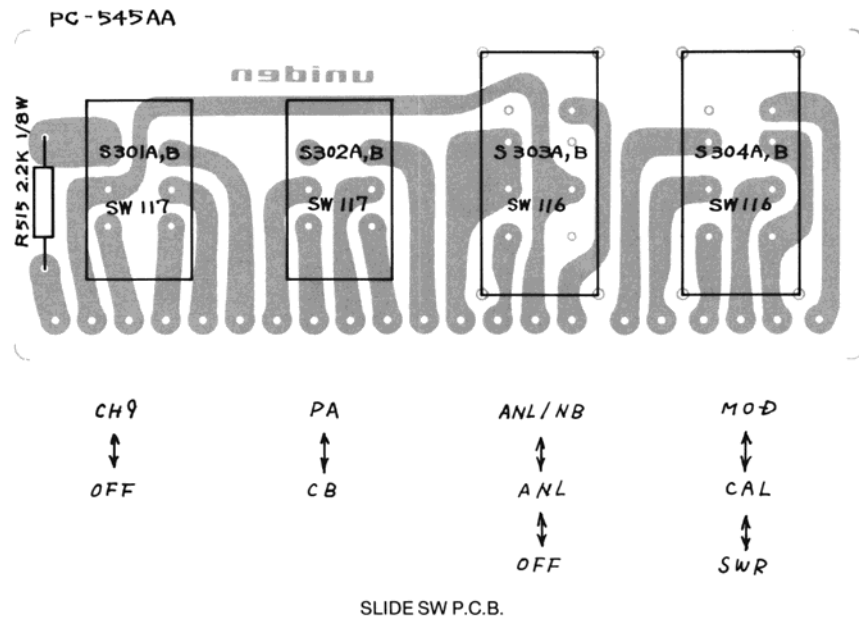

PUSH SW P.C.B.

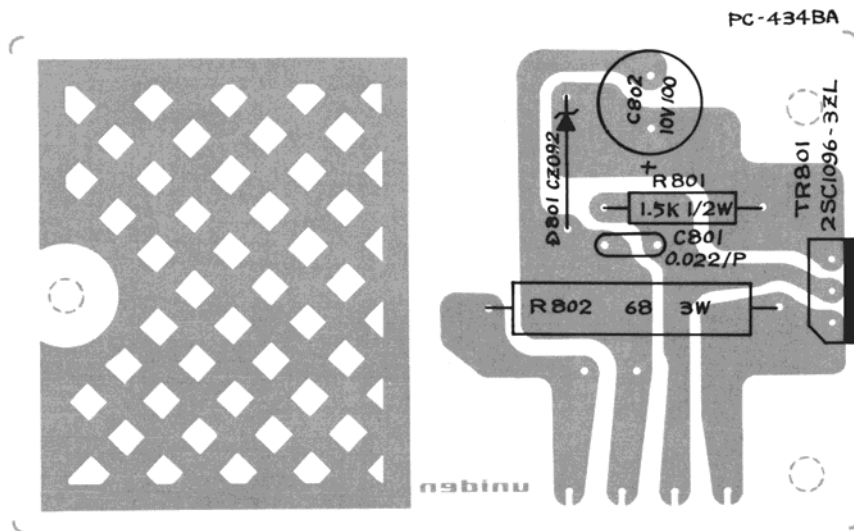

CLOCK AVR P.C.B.

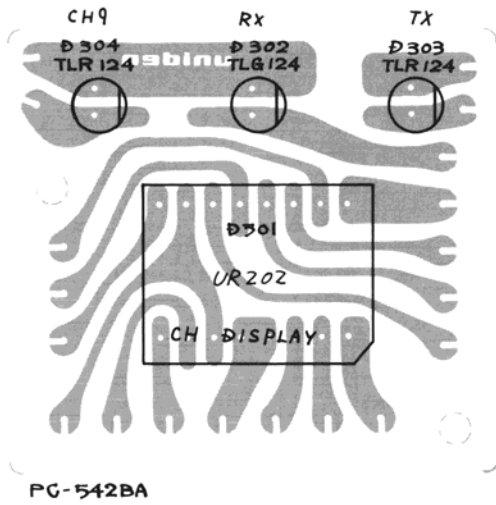

LED P.C.B.

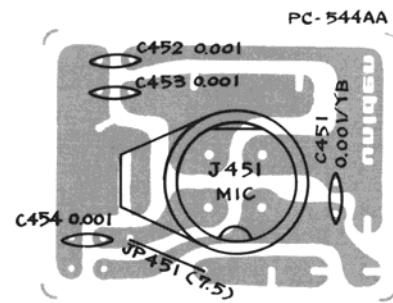

MICROPHON JACK P.C.B.

STALKER XII Parts List

Computer No.	Symbol No.	Part No.	Description
D1701	IC 1	DDEY146001	IC TA7222P AF Power
D1568	IC 2, 3	DDEY109001	IC TA7310P VCO TX Mixer
D1757	IC 4	DDEY147001	IC UPD2816C PLL
E1256	IC 701	DDEY148001	TM4801P, Clock
B1082	TR 4	DDCY011001	FET 2SK104-H
B1081	TR 3, 21	DDCY001002	FET 2SK19 BL
B1011	TR 16, 1/24	DDBY003001	Transistor 2SA733P
B1024	TR 15	DDBY273001	Transistor 2SC458 C
B1029	TR 1, 8, 9, 13, 23, 203, 701	DDBY224003	Transistor 2SC945 A
D1761	TR 18, 202, 801	DDBY227002	Transistor 2SC1096-3ZL
D1703	TR 2	DDBY295002	Transistor 2SC1674-L
D1068	TR 5, 6, 7, 14, 22, 25	DDBY259001	Transistor 2SC1675-L
L1171	TR 11	DDBY256002	Transistor 2SC2028-B/20
L1172	TR 10	DDBY257001	Transistor 2SC2029-B/10
B1229	TR 12	DDBY270001	Transistor 2SC2076 C
E1294	TR 201	DDBY412001	Transistor 2SD586 R
C1050	D 6, 7, 11, 12, 28	DDAY001001	Diode, IN 60 AM
C1051	D 9, 10	DDAY001002	Diode, IN 60 P
C1036	D 4	DDAY051001	Diode, 1S34
C1053	D 5	DDAY063001	Diode, 1S2075 K
D1806	D 1, 2, 3, 15, 17, 19, 20, 22, 23, 24, 27, 502, 503, 504, 505, 506, 507, 508, 509, 510, 702, 16	DDAY069001	Diode, 1S2076
E1295	D 201, 202, 203, 204	DDAY105002	Diode, GM-3Y
E1005	D 13, 26	DDAY002001	Diode, SR1K-1
E1001	D 205	DDAY009003	Diode, Zener BZ162
C1004	D 206	DDAY008002	Diode, Zener WZ 071
D1762	D 21	DDAY020004	Diode, Zener XZ 051
D1577	D 25	DDAY020005	Diode, Zener XZ 086
E1002	D 801	DDAY010002	Diode, Zener CZ 092
E1235	D 501	DDAY082001	Diode, LED SL 1221, CH
E1297	D 701	DDAY107001	Diode, LED TLR2077, Clock
D1706	D 303, 304	DDAY100001	Diode, LED TLR124, TX, CH9
D1707	D 302	DDAY116001	Diode, LED TLG 124A
B1267	D 18	DDAY067001	Diode, Vari-Cap 1S2687 D
E1008	D 14	DDAY006003	Diode, Vari-Cap 1S2688-EA
L1199	L 1	LLAY029001	LA 029 Coil
C1200	L 25	LLAY088001	LA 088 Coil
D1764	L 6	LLAY106001	LA 106 Coil
D1765	L 2	LLAY138001	LA 138 Coil

Computer No.	Symbol No.	Part No.	Description
D1583	L 19	LLAY166001	LA 166 Coil
D1205	L 4	LLAY180001	LA 180 Coil
D1214	L 23	LLAY182001	LA 182 Coil
D1258	L 24	LLAY198001	LA 198 Coil
D1584	L 18	LLAY201001	LA 201 Coil
D1587	L 7	LLAY204001	LA 204 Coil
D1766	L 8	LLAY207001	LA 207 Coil
D1810	L 17	LLAY208001	LA 208 Coil
D1711	L 21	LLAY217001	LA 217 Coil
D1767	L 5	LLAY274001	LA 274 Coil
D1768	L 20	LLAY275001	LA 275 Coil
D1769	L 3	LLAY277001	LA 277 Coil
E1154	L 10, 16	LLCY018001 or LLCY072001	LC 018 Coil LC 072 Coil
C1201	L 13	LLCY019001 or LLCY073001	LC 019 Coil LC 073 Coil
E1156	L 14	LLDY012001 or LLDY033001	LD 012 Coil LD 033 Coil
D1771	L 12	LLEY088001 or LLEY092001	LE 088 Coil LE 092 Coil
D1772	L 11	LLEY089001 or LLEY093001	LE 089 Coil LE 093 Coil
D1580	L 15	LLDY087001	LD 087 Coil
D1727	L 9	LLDY071001	LD 071 Coil
E1298	L 26	LLZY001001 or LLZY016013	LZ 001 Inductor, Molded (10 uH) LZ 016
B1218	L 22	LLZY001013 or LLZY016025	LZ 001 Inductor, Molded (100 uH) LZ 016
E1296	T 301	TTFY150001	TF 150 Power Transformer
D1579	T 1	TTFY120001	TF 120 Output Transformer
D1209	T 2	TTFY017001	TF 017 Coil, AF, Choke
E1258	VR 1	RRVY189001	RV 189 300 ohm B Res., Semi-Fixed
E1202	VR 201, 6	RRVY189002	RV 189 500 ohm B Res., Semi-Fixed
D1775	VR 4	RRVY189006	RV 189 20K ohm B Res., Semi-Fixed
E1334	VR 2	RRVY189013	RV 189 30K ohm B Res., Semi-Fixed
E1239	VR 5	RRVY189007	RV 189 50K ohm B Res., Semi-Fixed
D1776	VR 3	RRVY189008	RV 189 100K ohm B Res., Semi-Fixed
E1299	VR 301	RRVY287001	RV 287, 1K ohm B RF Gain Res., Var.
E1300	VR 302, 303	RRVY333001 or RRVY340001	RV 333, 50K ohm A Tone, Vol. RV 340
E1301	VR 304	RRVY331001	RV331, 50K ohm B
E1302	VR 305	RRVY074001 or RRVY159001	RV 074 5K ohm B SWR, CAL RV 159
D1778	VR 306	RRVY039001 or RRVY157001	RV 039 20K ohm Delta Tune RV 157
E1303	VR 307	RRVY293001 or RRVY341001	RV 293 5K ohm A Mike Gain RV 341
B1273	X-1	QQXY074001	Crystal, QX-074- 10.240 MHz

Computer No.	Symbol No.	Part No.	Description
E1304		PPCY407013	PC Board, PC 407 AC, Main
E1305		PPCY410013	PC Board, PC 410 AC Pwr Supply
E1268		PPCY541001	PC Board, PC 541AA, Clock
E1306		PPCY451011	PC Board, PC 451AA, CH SW
E1307		PPCY542021	PC Board, PC 542BA, LED
E1308		PPCY545011	PC Board, PC 545AA SW
E1309		PPCY398011	PC Board, PC 398AA, SP Jack
E1310		PPCY311011	PC Board, PC-311AA, Phone Jack
E1266		PPCY443011	PC Board, PC 443AA Clock SW
E1311		PPCY434021	PC Board, PC 434BA, Clock AVR
E1312		PPCY544011	PC Board, PC 544AA, Mic Jack
D1785	XF-1	FFLY055001	Filter, Crystal 1st IF FL-055
D1749		MDMP406425	Knob, Channel
D1750		MDMP402181	Knob
D1837		MDMP404046	Knob, Push Button
E1313		MDMP406567	Spacer, Rubber, LED
E1279		MDNP407383	Nameplate, Control A
E1314		MDNP407384	Nameplate, Control B
E1315		MDNP307385	Nameplate Control
E1316		MDNP407386	Nameplate, Brand
E1317		MDNP407388	ID Plate, FCC
E1283		MDAP407389	Panel, Front Display
E1284		MDAP407390	Panel, Front Display
E1285		MDAP407391	Optical Filter, Clock
E1286		MDAP404097	Optical Filter, Display
E1318		MZPT233601	Owners Manual
E1319		MZPT233607	Schematic Diagram/Bill of Material
D1784	CF-1	FFLY009001	Filter, Ceramic 2nd IF FL009
E1320	S 501	SSRY152001	Switch, Rotary SR 152 CH
E1220	S 305	SSWY099001	Switch, Slide SW099, SW099 AC-DC
E1321	S 303, 304	SSWY116001	Switch, Slide SW 117 CH 9-Off, PA-CB
E1335	S 701, 702, 703, 704, 705, 706, 707	SSWY183001	Switch Push, SW-183
E1322	SP 301	ASPY031001	Speaker SP-031
E1323	M 302	ZMTY187001	SWR/MOD Meter MT 187
E1324		AMKY076001	Microphone MK 076
E1325	PL 302	VPLY068004	Pilot Lamp PL 068
E1326	PL 301	VPLY068005	Pilot Lamp PL 065
C1131	J 302	JJKY052001	Receptacle, DC Power JK 052
E1224	J 401, 402	JJKY010001	Jack, SP, JK 010 (PA, EXT)
D1318	J 451	JJKY058001	Jack, Microphone JK 058
E1223	J 601	JJKY005002	Jack, Phone JK 005
E1327	J 701, 702	JJKY046016	Jack, JK 046
E1328		ZFHY002001	Holder, Fuse FH-002

Computer No.	Symbol No.	Part No.	Description
E1329	TP 1, 2, 3, 4 5, 6	JTPY029001	Terminal Checkpoint TP029
E1230		WWZY022001	AC Power Cord
E1330		WZDZ070101	DC Power Cord
E1331		MDBP204583	Cover, Top
E1332		MDBP204592	Cover, Bottom
E1333		MDMP107377	Panel, Front