

This Manual is provided by
CBTricks.com

Someone who wanted to help you repair your equipment
scanned this manual.

If you would like to help us put more manuals online support us.

Supporters of CBTricks.com paid for the hosting so you would have this file.

CBTricks.com is a non-commercial personal website was created to help promote the exchange of service, modification, technically oriented information, and historical information aimed at the Citizens Band, GMRS (CB "A" Band), MURS, Amateur Radios and RF Amps.

CBTricks.com is not sponsored by or connected to any Retailer, Radio, Antenna Manufacturer or Amp Manufacturer, or affiliated with any site links shown in the links database. The use of product or company names on my web site is not endorsement of that product or company.

If your company would like to provide technical information to be featured on this site I will put up on the site as long as I can do it in a non-commercial way.

The site is supported with donation from users, friends and selling of the Galaxy Service Manual CD to cover some of the costs of having this website on the Internet instead of relying on banner ads, pop-up ads, commercial links, etc. to pay my costs. Thus I do not accept advertising banners or pop-up/pop-under advertising or other marketing/sales links or gimmicks on my website.

ALL the money from donations is used for CBTricks.com I didn't do all the work to make money (I have a day job). This work was not done for someone else to make money also, for example the ebay CD sellers.

All Trademarks, Logos, and Brand Names are the property of their respective owners.
This information is not provided by, or affiliated in any way with any radio or antenna Manufacturers.
Thank you for any support you can give.

OPERATION AND MAINTENANCE

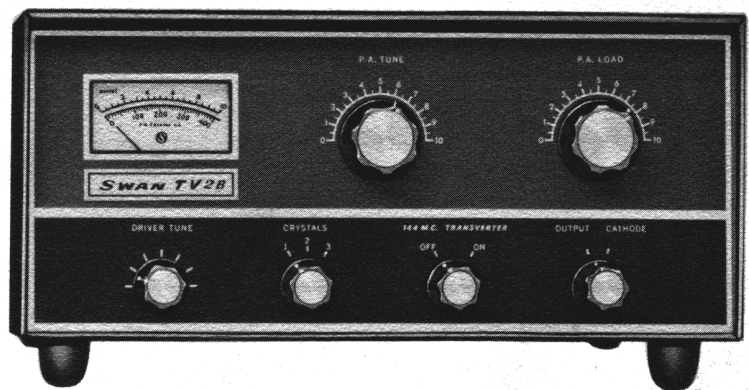

144-148 MC TRANSVERTER, SWAN MODEL TV-2B



SWAN

ELECTRONICS

Oceanside, California

A Subsidiary of Cubic Corporation

CONTENTS

1. GENERAL DISCUSSION
2. TECHNICAL SPECIFICATION
3. CIRCUIT DESCRIPTION
4. CRYSTAL SELECTION
5. BLOCK DIAGRAM
6. INSTALLATION
7. OPERATION
8. ALIGNMENT
9. CHANGING I.F. RANGE

144-148 MC RECEIVING AND TRANSMITTING CONVERTER SWAN MODEL TV-2B

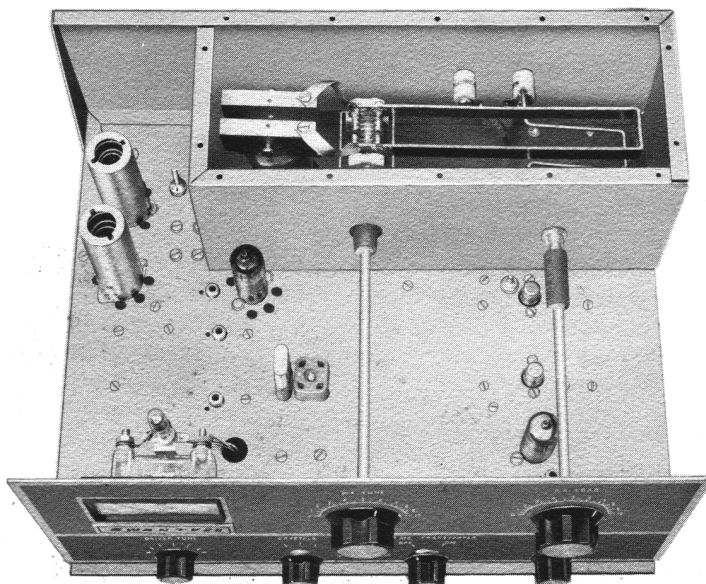

1. GENERAL DISCUSSION

1.1 The Swan model TV-2B is a crystal controlled transmitting and receiving converter for the 2 meter band designed to operate with Swan Tranceivers, models 250, 250-C, 350, 350-C, 400, 500 and 500-C. The 20 meter band has been chosen as the standard intermediate frequency, (I.F.), since it will provide excellent stability and frequency readout. However, the TV-2B is also available with its I.F. range in the 15 meter, 10 meter, or 6 meter amateur bands. The various I.F. ranges may be ordered through Swan dealers, or when required, the TV-2 may be quite easily modified for a different I.F. range.

1.2 In the standard model TV-2B with 20 meter I.F., the 14 mc output from the Transceiver is heterodyned with a 130 mc crystal controlled signal to produce a 144 mc output from the TV-2B. As the Transceiver is tuned from 14 mc up to 14.35 mc, the Converter output moves upward in frequency, always 130 mc plus the Transceiver frequency. In receiving mode, the incoming signal at 144 mc is heterodyned with the 130 mc crystal controlled signal, producing a difference frequency of 14 mc. The difference frequency, or I.F. signal, is received by the Transceiver the same way

as any other 14 mc signal. As the Transceiver is tuned from 14 to 14.35 mc, it will be monitoring signals coming in from 144 to 144.35 mc. In other words, the TV-2B Transverter simply converts the 144 to 144.35 mc portion of the 2 meter band to cover the 14 to 14.35 mc range, and as far as the Transceiver is concerned, it tunes and operates just as it does when being operated on 20 meters. It is only necessary that the crystal frequency, 130 mc, be added to the Transceiver dial reading. If the Transceiver will tune higher than 14.35 mc, then the frequency range on 2 meters will go correspondingly higher. For instance, the model 500-C Transceiver tunes to 14.45 mc, so the 2 meter range when using 130 mc injection will go up to 144.45 mc.

1.3 A 3 position crystal selector switch on the TV-2B provides for selection of three conversion ranges. Thus, three segments of the 2 meter band may be covered. Normally, this will be three adjacent segments at the low end, for example: 144 to 144.45 mc, 144.45 to 144.9 mc, and 144.9 to 145.35 mc. These three ranges require crystal injection frequencies of 130, 130.45, and 130.9 mc, respectively.

1.4 15 Meter I.F.

If an I.F. range in the 15 meter amateur band is preferred, operation will be essentially the same as with 20 meter I.F., except that the crystal injection frequency will be 144 minus 21 mc instead of 144 minus 14. Tuning the Transceiver across the 15 meter band, from 21 to 21.45 mc, will tune an equivalent .45 mc segment of the 2 meter band. A crystal injection frequency of 123 mc will thus result in a range of 144 to 144.45 mc, etc.

1.5 10 Meter I.F.

If an I.F. range in the 10 meter amateur band is selected, a wider segment of the 2 meter band will be tuned with each crystal frequency. The 10 meter band tunes from 28 to 29.7 mc, or 1700 KC as compared to 450 KC on 15 meters and 350 KC on 20 meters. The Swan Transceivers tune the 10 meter band in one range. Thus, if the Transverter I.F. is on 10 meters, a crystal injection frequency of 116 mc will result in an operating range of 144 to 145.7 mc. (116 plus 28 mc, and 116 plus 29.7 mc). Thus, a larger portion of the 2 meter band can

be covered by selecting a 10 meter I.F. range. In fact, by proper selection of the three crystal frequencies, the entire 2 meter band, from 144 to 148 mc may be covered. However, overall stability and frequency readout will not be quite as good as with a 20 meter I.F. Since most operating in the 2 meter band does not cover the entire 4 mc band width, but is concentrated in small segments, the 20 meter I.F. range is generally recommended, and has been designated as standard.

1.6 6 Meter I.F.

When the Swan 250 or 250-C Transceiver is used with the TV-2B Transverter, the I.F. range will be in the 6 meter band. The advantage in this case is that the entire 2 meter band will be covered with one crystal in the TV-2B. The crystal injection frequency will be 144 minus 50 mc, or 94 mc. In tuning the Transceiver from 50 to 54 mc, the operating frequency will tune from 144 to 148 mc. Since the vernier dial on the Transceiver covers .5 mc, (500 KC), frequency readout and stability will be good.

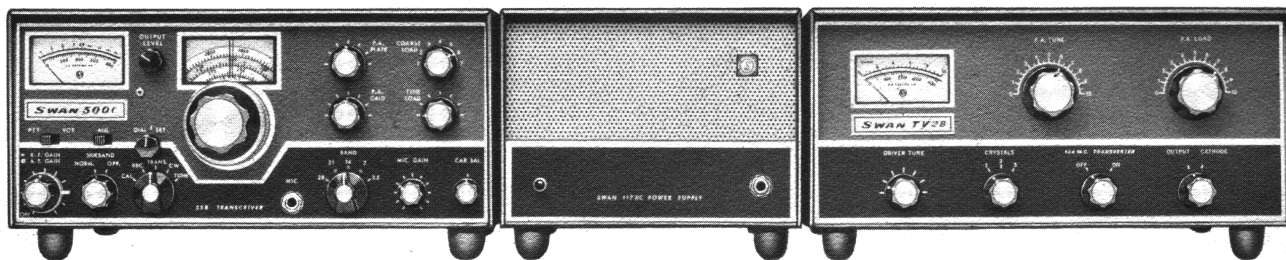

2.0 TECHNICAL SPECIFICATIONS:

- (a) **Frequency Range, Output:** 144-148 MC
- (b) **Frequency Range, Input:** 20 meter band standard. 15, 10, or 6 meter bands, optional.
- (c) **Transmitter Power Rating:** 240 watts PEP input with single sideband voice modulation, 180 watts CW input, 75 watts AM input. Power output in TUNE mode: 80 to 100 + watts.
- (d) **Transmitter Output Impedance:** 50 to 75 ohm coaxial cable, series tuned link coupling.
- (e) **Transmitter Distortion Products:** Approx. 30 db below rated output.
- (f) **Receiving Converter:** Nuvistor Cascade with Noise Figure less than 3 db.
- (g) **Metering:** P.A. Cathode Current, 0-400 Ma. Relative Output, 0-10.
- (h) **Panel Controls:** P.A. Tune, P.A. Load, Driver Tune, Crystal Selector, Meter Switch, 144 mc Transverter on-off.
- (i) **Rear Panel Controls and Connectors:** P.A. Bias Adjust, Power Supply Connector, Relay Control Jack, I.F. Output Jack, Coax. Antenna Connector, Lo Frequency Antenna.
- (j) **Tube Complement:** 6JK6 Injection Amp., 12BY7 Transmit Mixer, 5763 Driver, 5894B/8737 Power Amplifier, Two 6CW4 Nuvistors in Rec. R.F. Cascade, 6HA5 Rec. Mixer.
- (k) **Transistors:** 2N706 Crystal Osc., 2N706 Freq. Multiplier.
- (l) **Power Requirements,** (Normally supplied by Swan 117XC power supply, operating both the Swan Transceiver and the TV-2 Transverter): Filaments, 12.6 volts AC or DC, 2.04 amps. Medium Voltage, 275 volts DC, 120 Ma. High Voltage, 800 volts DC, 240 Ma. Bias, 110 volts negative DC, 6.4 Ma. Osc. Supply, 10 volts regulated negative DC, at 9 Ma. Relay Supply, 12 volts DC at 125 Ma.
- (m) **Dimensions:** 13 in. wide, 5½ in. high, 11 in. deep. Weight, 13 lbs.

3.0 CIRCUIT DESCRIPTION

3.1 Receiving Mode.

An incoming signal in the 144-148 mc range is first amplified by the 2 stage cascode circuit which uses 6CW4 Nuvistors, providing excellent sensitivity and low noise figure. The amplified signal is then heterodyned in a 6HA5 triode mixer with the crystal injection signal. The frequency difference or "I.F.", is selected by a resonant circuit, and then coupled into the Transceiver where it is received exactly like any other received signal in the I.F. range. The crystal injection signal is generated by a transistorized crystal oscillator which drives a frequency tripling stage. Thus, the crystals are actually oscillating at one-third the required injection frequency.

3.2 Transmitting Mode

Transmitting output from the Transceiver is coupled into the cathode circuit of the 12BY7 transmit mixer stage in the TV-2B. Here it is heterodyned with the crystal injection signal. The sum of the two frequencies falls in the 2 meter band, and is amplified first by the 5763 tuned driver stage, and then by the 5894-B Power Amplifier stage. Output is coupled into the 2 meter antenna system through a coaxial

cable connector. The crystal injection signal is derived from the same crystal oscillator and frequency tripler circuit that is used in Receive Mode, with further amplification by a 6JK6 pentode amplifier stage providing the necessary injection voltage.

3.3 Power Supply Requirements

The same Swan model 117-XC power supply which provides operating voltages for the Swan Transceiver is used to power the TV-2B Transverter. The additional power requirements are adequately provided by the 117-XC:

- (a) 12.6 volts AC at 2.04 amps is required for filaments.
- (b) 12 volts DC at 125 ma for the TR relay.
- (c) 110 volts negative DC for Bias.
- (d) 275 volts DC at 120 ma medium voltage.
- (e) 800 volts DC at 240 ma high voltage.

Note: 10 volts regulated negative DC at 9 ma is required for the transistor oscillator and frequency tripler stage. This voltage is supplied by the Swan Transceiver, and is one of the interconnecting changes to be made in the Transceiver, and described under "Installation, Transceiver Modifications," on page 5.

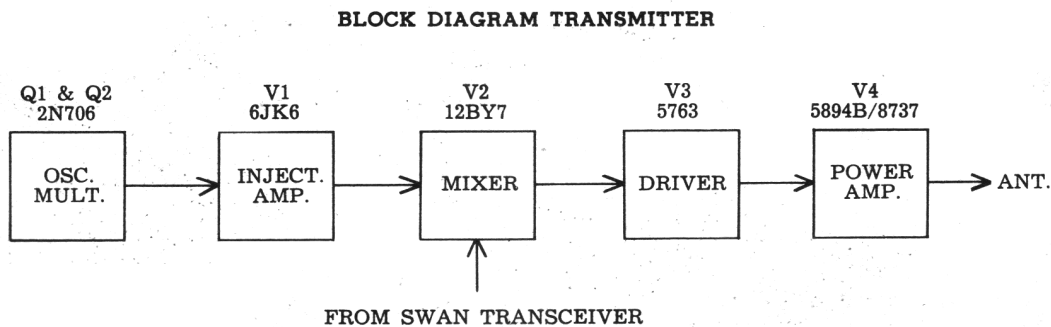
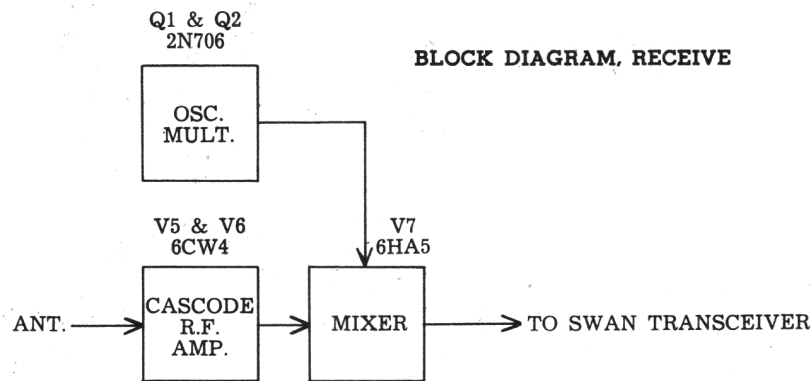

4.0 CRYSTAL FREQUENCY SELECTION

4.1 The formula for calculating the crystal frequency to be used in the TV-2B is:

$$F_x = \frac{\text{Signal Freq.} - \text{I.F.}}{3}$$

Where F_x is the crystal frequency, Signal Freq. is the desired operating frequency of the TV-2B, and I.F. is the operating frequency of the Transceiver.

When ordering crystals specify parallel resonant and pico farad load.

4.2 For example, for a signal frequency of 144 mc, and an I.F. of 14 mc, the crystal frequency will be 144 minus 14, or 130, divided by 3, which calculates to 43.333 mc. This will normally be the crystal in position 1 of the crystal selector switch. With this crys-

tal the tuning range will extend from 144 to 144.45 mc as the Transceiver is tuned from 14 to 14.45 mc.

4.3 To calculate crystal number 2, subtract 14 from 144.45, and divide the difference by 3. The result is 43.483 mc, and with this crystal the tuning range will be from 144.45 to 144.9 mc as the Transceiver is tuned from 14 to 14.45 mc.

This same method of calculation may be used to place TV-2B operation in any desired portion of the 144-148 mc band.

4.4 The following chart lists some of the various arrangements which may be selected for Swan Transceivers.

Swan Transceiver	I.F. Tuning Range	TV-2B Range	Crystal Freq.
Swan 350-C and 500-C	14-14.45	144.00-144.45	43.333 mc
		144.45-144.90	43.483
		144.90-145.35	43.633
		145.35-145.80	43.783
		145.80-146.25	43.933
		146.25-146.70	44.083
	21-21.45	144.00-144.45	41.000
		144.45-144.90	41.150
		144.90-145.35	41.300
		145.35-145.80	41.450
		145.80-146.25	41.600
		146.25-146.70	41.750
	28-29.7	144.00-145.70	38.666
		145.00-146.70	39.000
		146.50-148.20	39.500
Swan 350 and 500	14-14.35	144.00-144.35	43.333
		144.35-144.70	43.450
		144.70-145.05	43.566
	13.85-14.35	144.00-144.50	43.383
		144.50-145.00	43.550
		145.00-145.50	43.716
		145.50-146.00	43.883
	21-21.50	144.00-144.50	41.000
		144.50-145.00	41.166
		145.00-145.50	41.333
		145.50-146.00	41.500
	28-29.7	144.00-145.70	38.666
		145.00-146.70	39.000
		146.50-148.20	39.500
	Swan 250	50-54 mc	144-148

6.0 INSTALLATION

6.1 Remove the protective packing from around the 5894B power amplifier tube. First remove the TV-2B cabinet, and then the P.A. top cover. Make certain the 5894B is plugged all the way down in its socket, and that the plate connectors are secured.

6.2 The following modifications must be made in your Swan Transceiver before connecting the TV-2B.

- (a) Remove the bottom cover from the Transceiver, and locate the 12 pin power supply connector. If you have a 500-C it will be necessary to remove the brass cover plate from the TV filter box.
- (b) Locate Pin 11 on the power supply connector. If there is a wire lead already connected to Pin 11, remove it. It will not be needed. Connect a wire lead from Pin 11 to the -10 volt terminal of the Zener diode, D1601. This is a stud type 10 watt diode mounted on the chassis near the accessory socket hole. Connect to the lug which comes from the main body of the diode. This is the -10 volt terminal, and will supply the

regulated voltage to the crystal oscillator in the TV-2B.

- (c) Connect a .01 mfd. ceramic disc bypass from each of the Auxiliary relay terminals to a ground lug. These are the three terminals located on the back of the Transceiver chassis just behind the P.A. tubes. The three .01 bypasses should have a 500 volt rating.
- (d) Connect three .01 mfd. bypass capacitors from pins 4, 5, and 10 of the power supply connector to a ground lug. If you have the model 500-C, these bypasses may be connected outside the brass TV filter box. In this case, the .01 capacitors will connect from the feed thru capacitor to ground, and will thus be in shunt with the .001 mfd. feed thru.
- (e) The voltage dropping resistors for the zener diode (D1601) should be changed so that both are 500 ohms, if FM is experienced on your SSB signal. The best way to check is to listen to the signal on CW while keying the transmitter, no chirping or frequency shift should take place.

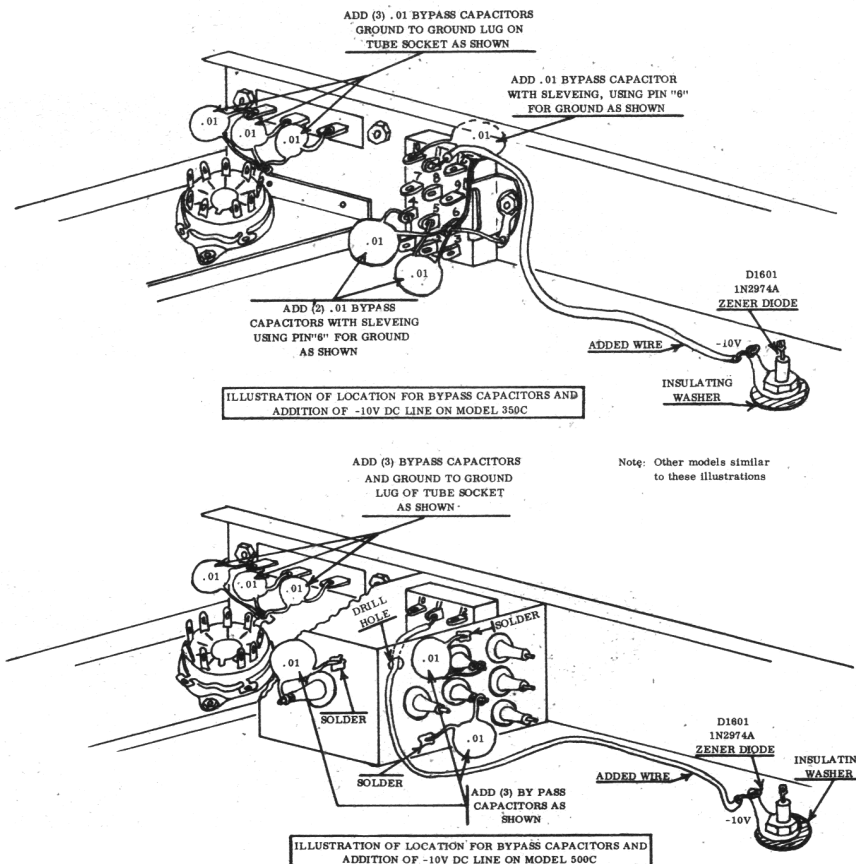

OTHER MODELS WILL BE APPROXIMATELY SIMILAR.

6.3 Make all connections between the TV-2B, Transceiver, and Power Supply as illustrated below. Make certain that the relay control leads are properly connected so the TV-2B relay closes when the Transceiver is switched to Transmit Mode. Otherwise, output from the Transceiver can damage the TV-2B receiver circuitry.

6.4 Antenna

Any of the common antenna systems designed for use in the 2 meter amateur band may be used with the Swan Transverter provided the input impedance of the transmission line is not outside the capability of the matching network. The transmission line should be of the coaxial cable type. An antenna system should show a standing wave ratio of less than 2:1 when using 50 or 75 ohm coaxial transmission line. If open-wire or balanced type transmission line is used with the antenna, a suitable antenna tuner is recommended between the Transverter and the feedline. Various types of antennas are available from your dealer, and for the antenna builder, many are described in the amateur handbooks, also available from your dealer. Remember that even the most powerful transmitter is useless without a proper and efficient antenna system.

7.0 OPERATION

7.1 Transceiver Tuning

Set the Transceiver to the proper band, corresponding to the one the TV-2B is set up for. Tune-up procedure on the Transceiver is generally the same as when operating it directly into an HF antenna on that band, except that meter readings will not be as high as normal, since plate voltage to the output stage of the Transceiver has been reduced to plus 275. Note that P.A. Bias adjustment for the Transceiver should not be changed. Leave it at the

same setting as when operating normally at full voltage. During Transceiver tuning, you may disregard the TV-2B meter, but remember to **tune the Transceiver quickly, and not more than 10 seconds** at a time.

(a) For HF models 350, 350-C, 400, 500 and 500-C: Adjust P.A. Load controls until P.A. Plate dips to a cathode current reading of 150 ma. (Transceiver Meter)

(b) For 6 meter model 250: Set the meter switch to output position, and adjust P.A. Plate and P.A. Load controls for maximum meter reading. (Transceiver Meter)

7.2 TV-2B Tuning Adjustments

(a) Set the TV-2B Meter Switch to OUTPUT, and the TV-2 P.A. LOAD control to ten, (3 o'clock). Switch the Transceiver to TUNE position, and quickly adjust DRIVER TUNE and P.A. TUNE on the TV-2 for maximum meter reading (TV-2 Meter). Switch the Transceiver back to RECEIVE mode.

(b) Switch the Transceiver to TUNE position, and quickly adjust the P.A. LOAD control on the TV-2B for maximum output reading. Then reset the TV-2 P.A. TUNE control again for maximum output. Repeat peaking of P.A. LOAD and P.A. TUNE controls until maximum output reading is reached. Switch the Transceiver back to RECEIVE mode.

(c) **TV-2B BIAS ADJUSTMENT** Switch the Transceiver to normal SSB mode, (By pressing the Push-To-Talk button on the mic. with most models). Adjust the Carrier Balance control for Carrier Null, (Minimum Carrier). Then set the P.A. BIAS control on back of the TV-2B 60 ma. reading on the TV-2B meter. Note that the TV-2B Meter Switch must be in CATHODE position for this adjustment.

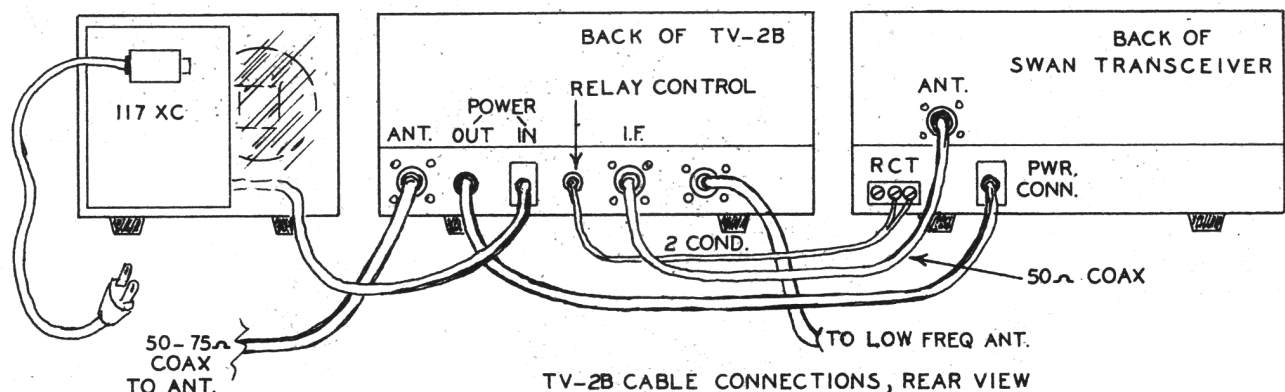

(d) **TV-2B CATHODE CURRENT** After both the Transceiver and the TV-2B have been properly adjusted, normal cathode current reading on the TV-2B meter will be between 200 and 250 ma. in TUNE position. In SSB Transmit mode, adjust the Transceiver MIC. GAIN for an average TV-2B Cathode Meter reading of about 125 ma. MIC. GAIN setting will normally be about 9 to 10 o'clock.

7.3 I.F. Leak-through

Very strong signals in the I.F. range may leak-through, giving the impression that you are hearing a weak 2 meter signal when in fact it is a very strong signal coming through at the Transceiver frequency. Be sure to connect the three .01 mfd. bypass capacitors to the Auxiliary Relay Switching terminals inside the Transceiver, as described in Item 6.2.

If signals in the I.F. range are still leaking through, connect a short ground strap from the transceiver chassis to the Transverter chassis. This may be copper braid or strap, about 1/2 inch wide. Also, connect a good ground line to the chassis, from a ground rod or water pipe. Refer to Item 9.9, paragraph "I" for adjustment of the I.F. trap.

8.0 CIRCUIT MODIFICATIONS WHEN CHANGING I.F. RANGE

The following chart indicates what changes must be made in the TV-2B when converting to a different I.F. range.

I.F. Range	Crystal Freq. See Chart Pg. 4.	C108 (Across L802)	C109 (Across L101)	C707 (Across L708)
14 mc (Std.)	43 approx.	None	None	20 pf
21 mc	41 approx.	None	None	None
28 mc	39 approx.	5 pf	None	None
50 mc	31.333	20 pf	5 pf	None (Connect jumper across half of coil L702)

8.1 After making the circuit changes when changing I.F. range, it will be necessary to adjust each of the changed circuits; that is: permeability tune coils L802, L101 and L702. Refer to alignment instructions in section 9. on page 8.

TV-2B VOLTAGE CHART											
Q1	E		B	C	Transistors, V1 PIN 1, and V2 PIN 1, measured with A200 μHY choke in series with meter lead.						
	T	*-5.9	*-8.0	0							
Q2	R	*-5.9	*-8.0	0							
	T	*-6.5	*-9.8	0							
		R	*-6.6	*-9.9	0						
PIN #	1	2	3	4	5	6	7	8	9	10	12
V1	T	*-2.38	.35	5.3AC	13.9AC	213	74	0			
	R	*-2.12	.41	5.3AC	13.9AC	241	83	0			
V2	T	*1.29	-7.12	0	13.9AC	13.9AC	5.3AC	237	181	0	
V3	T	258	NC	0	5.3AC	13.9AC	232	0	-7.95		
V4	T	0	*-33.3	258	.23	5.3AC	*-33.3	0	PLATES + 800VDC		
V5	R	—	59	—	0	—	—	—	—		0
V6	R	—	63	—	0	—	—	—	.46	—	6.3AC 0
V7	R	0	NC	13.9AC	6.3AC	136	0	2.29			

All measurements = are ± 10%

Measurements made with 20,000Ω per volt meter. From point indicated to chassis ground. Use 1.8 μHY choke on all RF points except those noted above.

*These points greatly effected by crystal activity and proximity of test lead etc. May vary by as much as 30% under different conditions.

9.0 ALIGNMENT

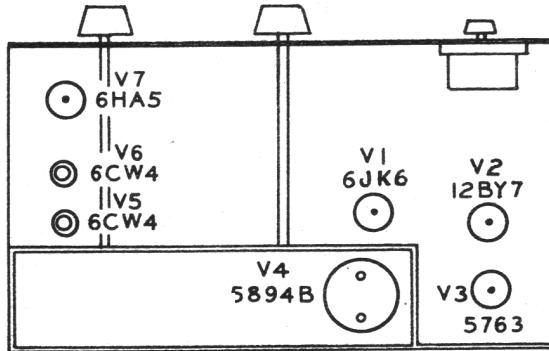

TV-2B TUBE LOCATION, TOP VIEW

- 9.1 An accurately calibrated Grid Dip Oscillator covering the necessary frequencies may be used to align the Transverter using the Grid Dip only. The procedure is the same except that you couple to the appropriate coil and tune the circuits for maximum indication on the Grid Dip Oscillator. For those without Grid Dip Oscillators, alignment can be accomplished with a meter as follows.

CAUTION

Dangerous high voltages are used in this unit. All safety precautions must be used at all times. Particularly when adjusting coupling to final tank circuit. Never touch anything inside the final tank circuit shield compartment with the power supply energized. Short tank circuit to ground after turning power supply off to bleed off filter capacitors before touching anything connected with the PA tank circuit.

EQUIPMENT NECESSARY FOR ALIGNMENT OF TRANSMITTER

VTVM — Hewlett Packard 410 B or equivalent.

Watt Meter with inductive load. Good for 125 watts or more at 144 to 148 mc (or dummy load) Output meter on Transverter may be substituted for watt meter.

Desirable but not necessary:

- Grid Dip Oscillator (GDO) measurements corporation Model 59 equivalent.
- Electronic Counter, or accurate receiver to check actual frequencies from 30 mc to 148 mc.

- 9.2 Disconnect screen voltage from final PA, V4 Pin 3, and V3 Pin 6.
- 9.3 Insert Hi, Low, and Mid range crystals in crystal sockets on top of chassis. (For selection of proper crystals see chart on page 4).
- 9.4 Oscillator Q1
- Set Transverter crystal switch to low frequency crystal. Set VTVM on —1 volt DC scale. Ground lead to Transverter

chassis, probe on Pin 1 of V1. Set core of L801 even with top of coil form, except for 50 mc if set core ¼ inch in winding. Adjust C804 for maximum indication on VTVM. Switch voltage off and on to see that crystal comes on every time.

If available, check frequency to see if crystal is in fact on proper overtone, with counter, receiver or GDO.

- Same as in A, except switch transverter crystal SW to high end of band.
- While switching between Hi and Low crystals, adjust C804 for same voltage indication on VTVM with either crystal. Peak L802 on Low crystal, then while switching between Hi and Low crystals readjust as necessary for same voltage indication on VTVM with either crystal. If necessary slightly adjust C804 for best balance.

9.5 For I.F. ranges at 14, 21, and 28 mc:

- Set VTVM to —10 volt DC scale, and move probe to Pin 2 of V2 (12BY7 Transmitter Mixer Grid) set 4 gang tuning condenser (Driver Tune) ¼ open. Adjust core of L101 for maximum indication on VTVM. If equipment is available check to see that frequency is 3 times crystal overtone.
- Repeat A, with 4 gang tuning condenser ¾ open, crystal switch on Hi crystal, and adjust C104 instead of L101.
- Switch between 2.A and 2.B adjustments until no further improvement in tracking can be achieved.
With 50 mc I.F. Range:
Since the 50 mc I.F. requires only one crystal proceed as follows. Completely close C104 then back off 1¼ turns. Set 4 gang condenser to ½ open. Adjust L101 for maximum indication on VTVM.

9.6 Transmitter Mixer V2

- It now becomes necessary to provide drive from the Swan Transceiver. See operating instructions and set for CW output.
- Set Transceiver and Transverter for 144 mc. Set 4 gang cond. ¼ open. Connect probe on VTVM to Pin 8 or 9 of V3. Leave on —10 volt DC scale. Energize transmitter and adjust core of L201 for maximum indication on VTVM. If equipment is available check to see that frequency is 144 mc.
- Same as A except 4 gang condenser ¾ open, Transceiver and Transverter adjusted to 148 mc. Tune C206 instead of L201 for maximum indication on VTVM.
- Switching Transceiver and Transverter from Low to Hi ends of band, repeat 3.B

and 3.C adjustments until proper tracking is achieved.

9.7 Transmitter Driver V3

- A. Connect screen of V3 (Pin 6). Set VTVM to -100 volt DC scale and connect probe to swinger on bias pot at rear of Transverter, R403 with voltages on but Transmitter not keyed, adjust bias pot for -30 volts DC.
- B. Adjust Transceiver and Transverter for 144 mc. Key Transmitter and adjust core of L301 for maximum rise on VTVM. (Approximately 8 volts)
- C. Adjust Transceiver and Transverter for 148 mc. Key Transmitter and adjust C301 for maximum rise on VTVM.
- D. Switching between Hi and Low end of band (144-148 mc) Adjust as in 4.B and 4.C until tracking is achieved.

9.8 PA Final V4

- A. Connect screen of final amplifier, V4 Pin 3. Connect 50 OHM load and watt meter to antenna jack on rear of Transverter. If watt meter is not available use the output meter on the Transverter as a relative indication. With no crystal in Oscillator circuit key Transmitter and adjust Bias control on rear of Transverter chassis (R403) for 60 ma of cathode current as indicated by the cathode switch position on the Transverter. Replace crystal.
- B. Adjust Transceiver and Transverter for 148 mc. Key Transmitter and resonate final tank circuit. Load final tank circuit (Final plate and load interact, so repeak several times until no further improvement is noted).
If unable to fully load final, (at least 200 ma of cathode current), it may be necessary to adjust coupling between L402 and L403. **CAUTION** remove voltages and discharge filter capacitors before touching final tank circuit as 800 volts DC is connected to final tank circuit. **CAUTION** do not overcouple as poor signal will result.
- C. Adjust coupling between L301 and L401 re-resonating C303 until maximum output is achieved as indicated by watt meter.
- D. Repeak all trimmer condensers for maximum output on watt meter.
- E. Set all controls for Low end of band, 144 mc. Resonate final load and PA tune. Adjust core in L301 for maximum output on watt meter. Peak output on watt meter by slight adjustment of cores in L101, L201 and L301.
- F. At this point it may be necessary to slightly adjust L801 to balance maximum output at both ends of band. Do not adjust for maximum output at either end but for similar output as near as

possible, unless all operation is intended at one end of band only.

- G. Check output in middle of band. It should equal or exceed band edges.
- H. Check carrier balance. If signal will not null, set is taking off, is mal-adjusted, or there is excessive carrier leak thru.

9.9 RECEIVER ALIGNMENT

Equipment necessary for alignment or receiver circuits. Signal generator covering 14 mc to 148 mc. Measurements Corp, Model 80 or equivalent. AC VTVM Hewlett Packard 410 B or equivalent.

- A. Since Oscillator has already been done in Transmitter alignment no adjustment is necessary at this time.
- B. During alignment of receiver keep PA plate of Transceiver and Driver Tune of Transverter peaked at the frequency being used for adjustment.

CAUTION during alignment of the Receiver do not key Transmitter as damage may result to the test equipment.

- C. With the filament of V5 disconnected, feed a signal at 144 mc to the antenna input of the Transverter. Increase output of signal generator until signal is heard in the Transceiver. Adjust core of L502 for minimum signal and C501 for maximum signal.
- D. Reduce output of signal generator and connect filament of V5 (Do Not solder at this time). When first RF stage has warmed up adjust core of L702 for maximum signal. To aid in finding peak, connect AC VTVM probe to Pin 12 of J404 being careful not to short any other pins.
- E. Adjust coupling of L601 and L701 for maximum signal.
- F. Using iron and brass cores check resonance of L501, L503, L601 and L701. Adjust as necessary. Recheck coupling L601 and L701 any time spacing of turns is altered.
- G. Disconnect filament of V5 and again adjust L502 and C501 as in step C. Reconnect filament of V5 and solder.
- H. Check mid frequency and high end of band. Make slight adjustments as necessary to achieve best over all performance. Adjust core of L702 at mid frequency. At this point also adjust L802 (Q2 Collector Coil), for maximum signal.
- I. Set signal generator to frequency that the Transceiver is tuned to. (14, 21, 28 or 50 mc). Adjust trap at antenna input connector J401. Tune C412 for minimum signal output of receiver.
- J. At 144 mc measure signal plus noise to noise ratio. It should be at least 8 db. If a noise generator is available, measure noise figure. It should be better than 3 db.

WARRANTY POLICY

SWAN ELECTRONICS CORPORATION WARRANTS THIS EQUIPMENT AGAINST DEFECTS IN MATERIAL OR WORKMANSHIP, EXCEPT FOR TUBES, TRANSISTORS, AND DIODES, UNDER NORMAL SERVICE FOR A PERIOD OF ONE YEAR FROM DATE OF ORIGINAL PURCHASE. TUBES, TRANSISTORS, AND DIODES ARE COVERED UNDER THE WARRANTY POLICY FOR A PERIOD OF 90 DAYS. THIS WARRANTY IS VALID ONLY IF THE ENCLOSED CARD IS PROPERLY FILLED IN AND MAILED TO THE FACTORY WITHIN TEN DAYS OF DATE OF PURCHASE. DO NOT SHIP TO THE FACTORY WITHOUT PRIOR AUTHORIZATION. THIS WARRANTY IS LIMITED TO REPAIRING OR REPLACING ONLY THE DEFECTIVE PARTS, AND IS NOT VALID IF THE EQUIPMENT HAS BEEN TAMPERED WITH, MISUSED OR DAMAGED.