

TABLE 5-3 SBE-29CB SYNTHESIZER MIXING SCHEME

CH.	CH. FREQ.	MASTER OSC. XTAL FREQ.	TX OSC. XTAL FREQ.	RX OSC. XTAL FREQ.
1	26.965		X11 = 10,000	X1 = 9.545
2	26.975	X5 = 16.965	X12 = 10,010	X2 = 9.555
3	26.985		X13 = 10,020	X3 = 9.565
4	27.005		X14 = 10,040	X4 = 9.585
5	27.015		X11	X1
6	27.025	X6 = 17.015	X12	X2
7	27.035		X13	X3
8	27.055		X14	X4
9	27.065		X11	X1
10	27.075	X7 = 17.065	X12	X2
11	27.085		X13	X3
12	27.105		X14	X4
13	27.115		X11	X1
14	27.125	X8 = 17.115	X12	X2
15	27.135		X13	X3
16	27.155		X14	X4
17	27.165		X11	X1
18	27.175	X9 = 17.165	X12	X2
19	27.185		X13	X3
20	27.205		X14	X4
21	27.215		X11	X1
22	27.225	X10 = 17.215	X12	X2
23	27.255		X14	X4

RECEIVE:

$$(\text{CH FREQ}) - (\text{M.O. FREQ}) - (\text{RX OSC FREQ}) = 455 \text{ KHz}$$

TRANSMIT:

$$(\text{M.O. FREQ}) + (\text{TX OSC FREQ}) = (\text{CH FREQ})$$

FIG. 5-4 TRANSMITTER TEST CONNECTION

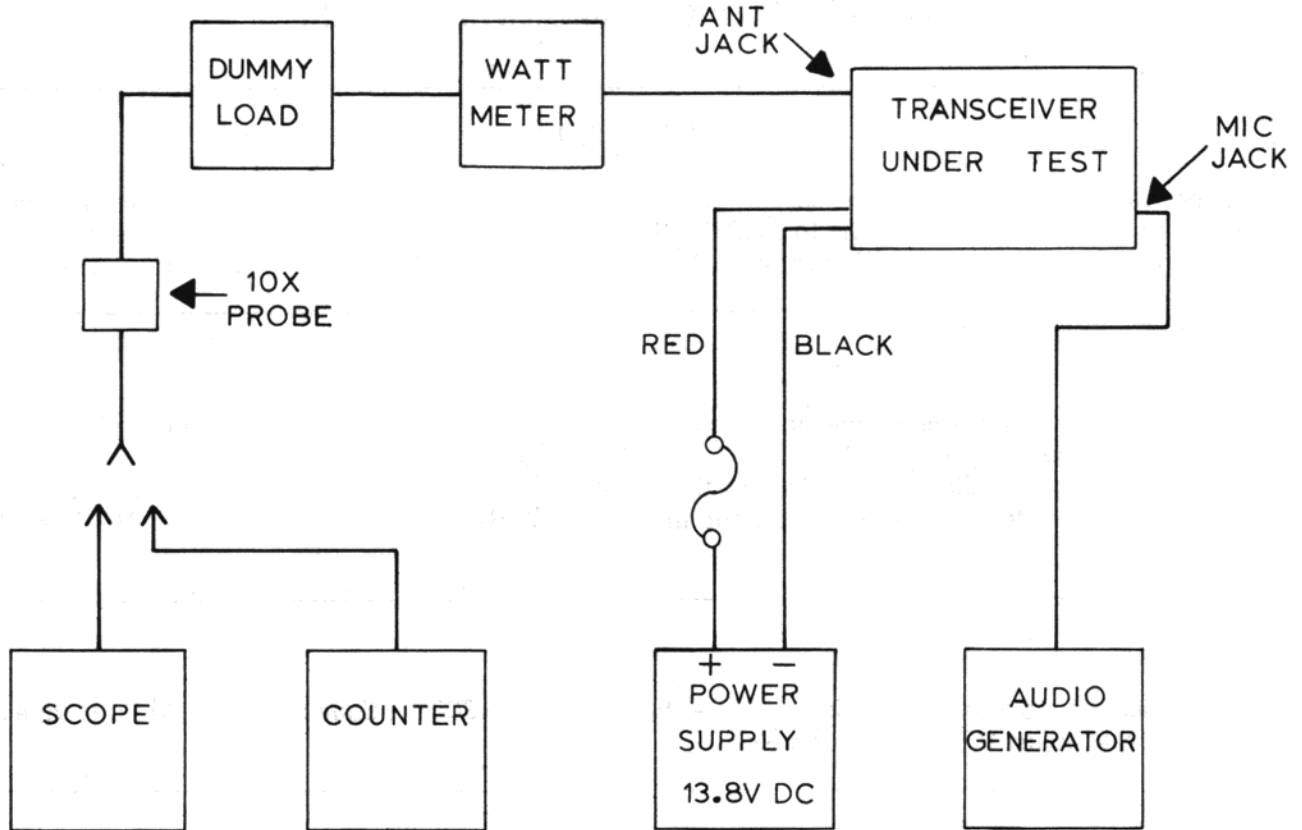

FIG. 5-5 RECEIVER TEST CONNECTION

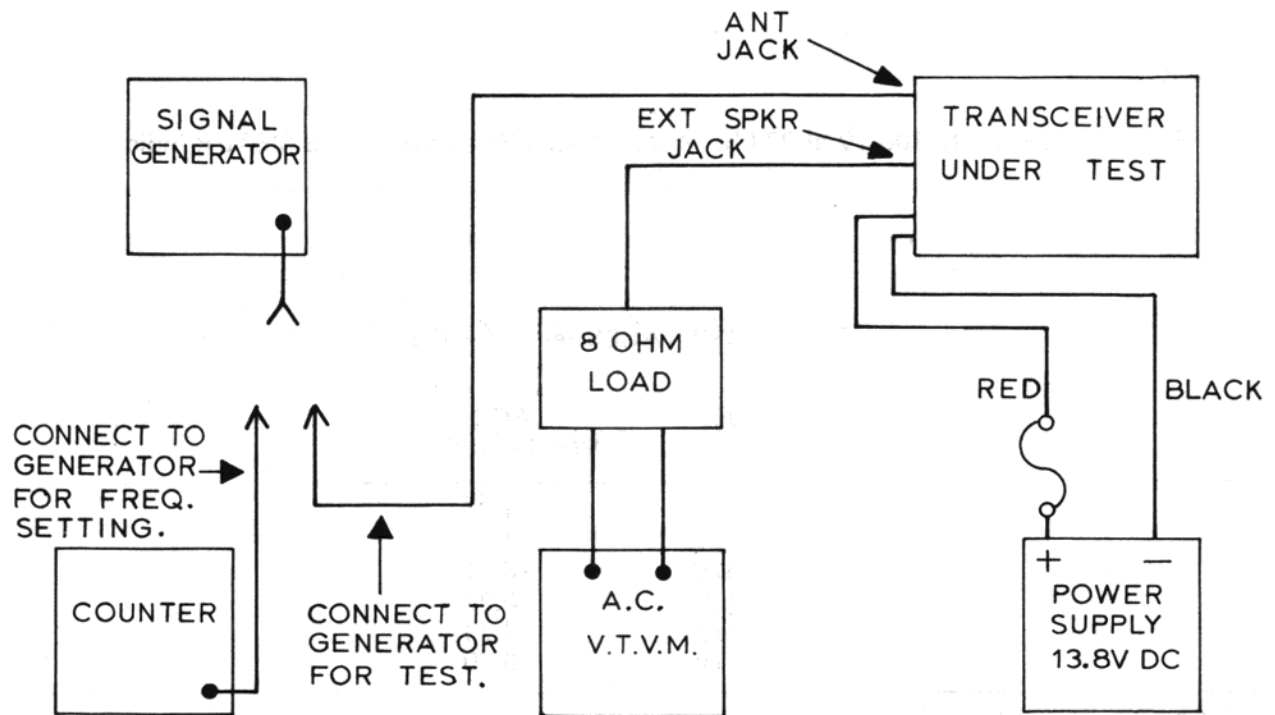

FIG. 5-6 RECEIVER ALIGNMENT PROCEDURE

INITIAL SET-UP	
<p>Connect an AC VTVM across the speaker or 8Ω load plugged into J3 EXT SP. Connect the RF signal generator to the antenna jack, set to 27.085 MHz 30% - 1 KHz modulation. Set the Channel Select SW to channel 11. Turn the squelch control full counterclockwise and the volume control full clockwise.</p>	
STEP 1	
<p>Adjust the RF output level of the signal generator to a level sufficient to produce about 2 VAC on the AC VTVM. Adjust T1, T2, L1, L2, T3, T4 and T5 for maximum indications on the AC VTVM. If at any time during the alignment procedure the audio level increases to more than 4 VAC, reduce the generator output level. Repeat adjustment until 0.7 μV RF signal produces about 2 VAC on the AC VTVM.</p>	
STEP 2	
<p>Turn squelch control full clockwise. Increase the RF signal to 300μV. Squelch should break. If squelch fails to break, adjust VR3 to break squelch.</p>	
STEP 3	
<p>Turn squelch control full counterclockwise. Set RF signal generator to 10 MHz. Adjust 10 MHz trap L9 for minimum indication on the AC VTVM.</p>	
STEP 4	
<p>Set RF signal generator to 100 μV at 27.085 MHz. Adjust VR5 to make the S METER indicate 9.</p>	

TABLE 5-7 AGC VOLTAGES versus RF INPUT LEVEL

INPUT LEVEL (1)	AGC VOLTAGES (2)
1μV	+1.35
10μV	+1.21
100μV	+0.97
1000μV	+0.82
10,000μV	+0.74
0.1V	+0.70

(1) Channel Frequency at Antenna Jack.

(2) Measured with 10MΩ input at junction R19 and C25.

FIG. 5-8 ALIGNMENT LAYOUT

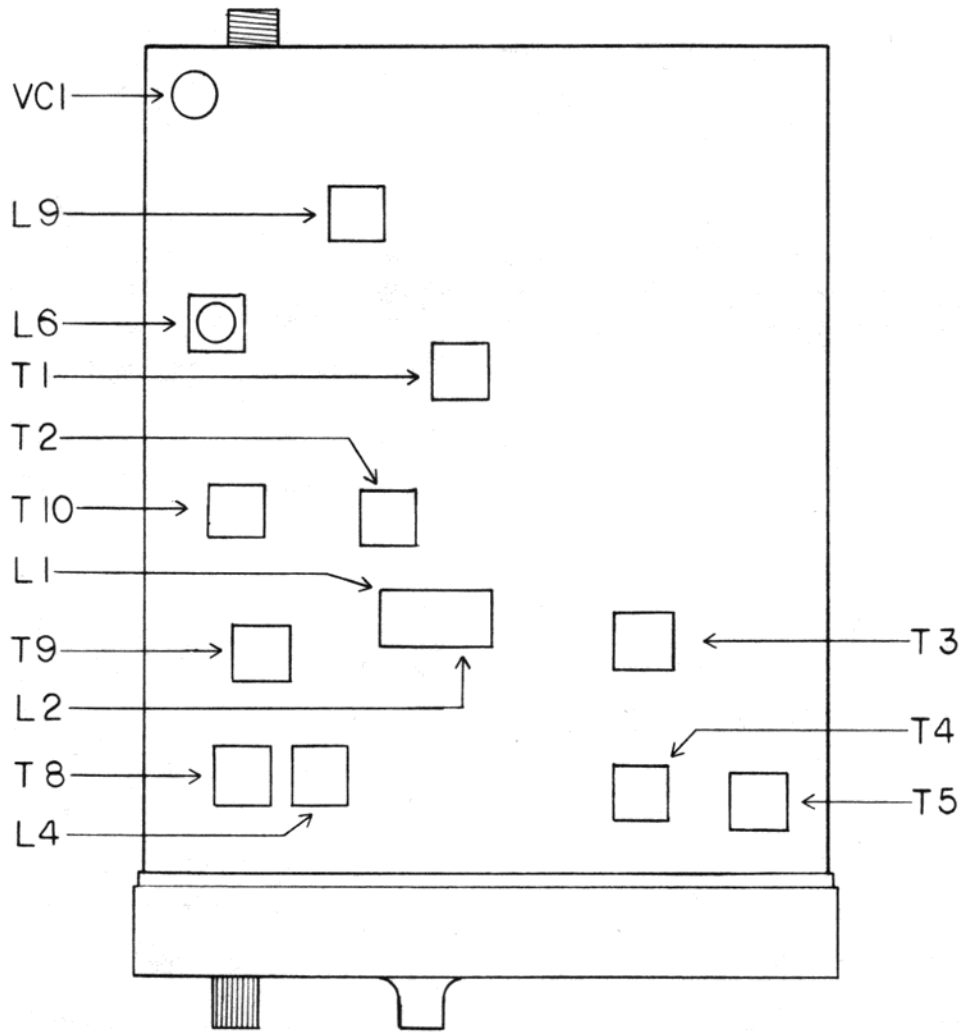

TABLE 5-9 RECEIVER INJECTION VOLTAGES

All injection voltages are at 30% - 1 KHz modulation at the specified frequency fed through a .01 MFD capacitor, and should produce at least 2 VAC audio output measured across the speaker or across an 8Ω load connected at EXT SP J2. Typical audio output voltages are given.

INJECTION POINT	INJECTION LEVEL	FREQUENCY	AUDIO OUTPUT
ANT JACK J1	1μV	Channel Freq.	4.6V
Base of Q4 - CP1 *	1μV	Channel Freq.	4.0V
Base of Q5 - CP2	10μV	Channel Freq.	2.8V
Base of Q6 - CP3	100μV	10.02 MHz	3.4V
Base of Q7 - CP4	300μV	455 MHz	5.0V
Base of Q8 - CP5	3000μV	455 MHz	2.5V

* CP numbers correspond to numbers in boxes on schematic diagram and component location drawing.

FIG. 5-10 TRANSMITTER ALIGNMENT PROCEDURE

INITIAL SET-UP	
	Connect the transceiver to a 13.8 VDC supply. Connect an audio oscillator to the MIC input, a wattmeter and dummy load to the antenna jack, an oscilloscope to the dummy load, and set the channel selector to channel 11. (See Figure 5-5.)
<u>STEP 1</u>	With no modulation, key the transmitter and adjust L4, L6, T8, T9, and T10 for maximum wattmeter indication.
<u>STEP 2</u>	Alternately, switch channel selector to channel 1 and 23. Adjust L4 and T8 for least change in wattmeter indication.
<u>STEP 3</u>	Adjust L8 and L10 for maximum wattmeter indication not to exceed 4 watts.
<u>STEP 4</u>	Set the audio oscillator to 1 KHz. Adjust output level for about 80% modulation. While observing scope, adjust L8 and L10 for best modulation symmetry.
<u>STEP 5</u>	Adjust the audio oscillator's level for 50% modulation. Read level on AC VTVM and increase level until the AC VTVM reads 8 times as great (about 18db). Adjust VR4 for 100% modulation.
<u>STEP 6</u>	Remove audio oscillator. Adjust VR6 until RFO METER reads the same as wattmeter.

FIG. 5-11 TRANSMITTER ALIGNMENT WAVEFORMS

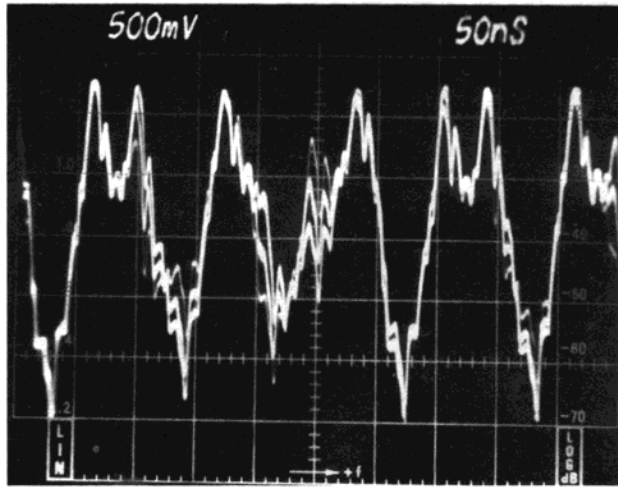

(a) D12 ANODE-TX MIXER 6

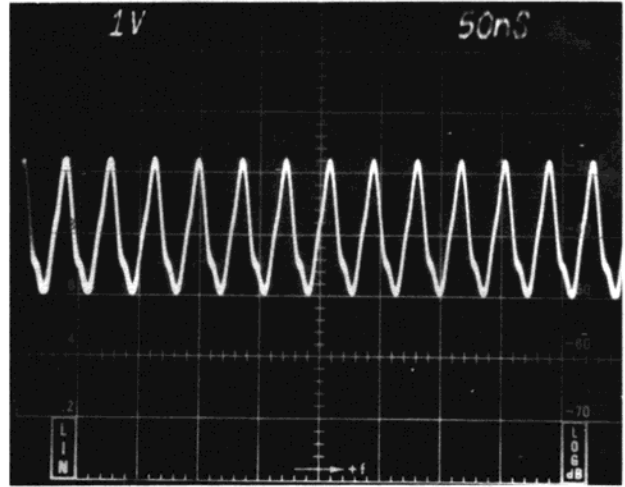

(b) Q15 COLLECTOR-TX BUFFER 7

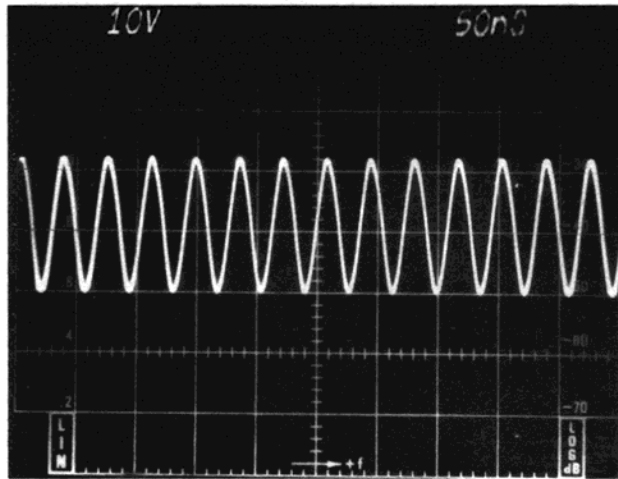

(c) Q 16 COLLECTOR-TX AMP 8

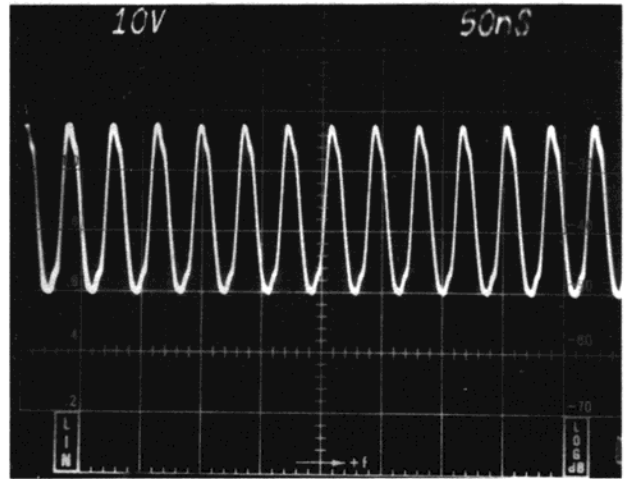

(d) Q17 COLLECTOR-TX DRIVER 9

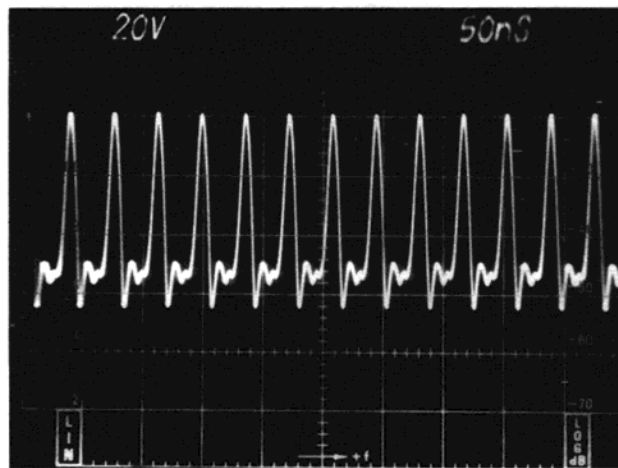

(e) Q18 COLLECTOR-TX FINAL 10

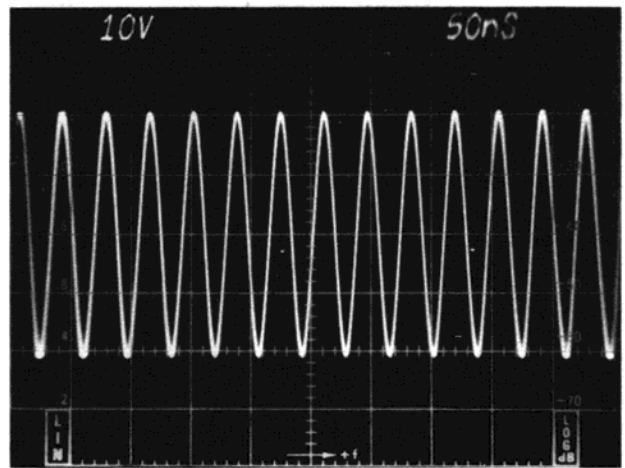

(f) ANTENNA JACK

FIG. 5-12 MODULATION WAVEFORMS

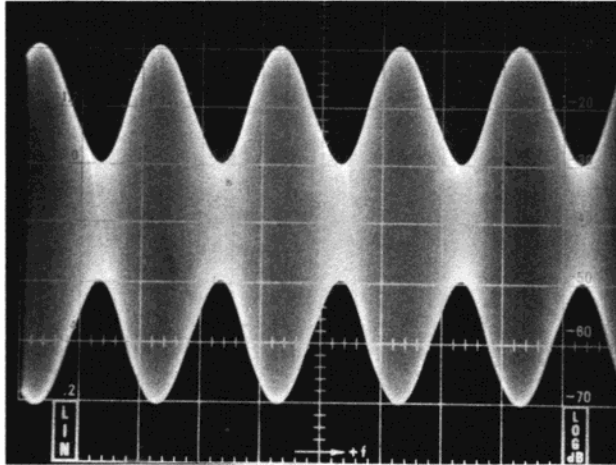

50% MODULATION

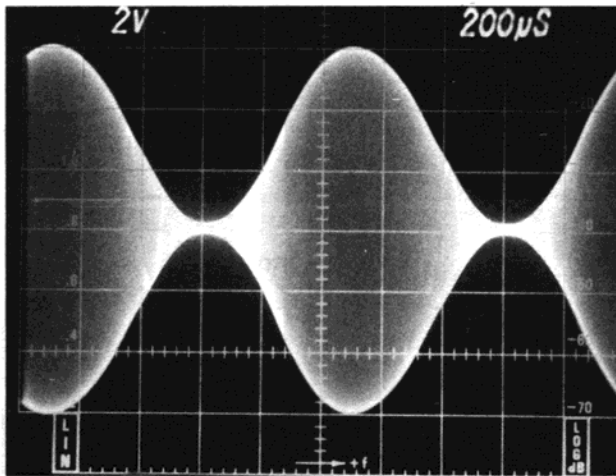

100% MODULATION

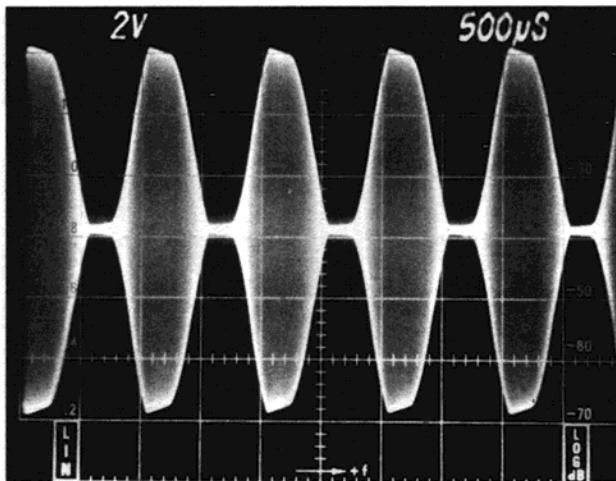

OVERMODULATION

FIG. 5-13 COMPONENT LAYOUT

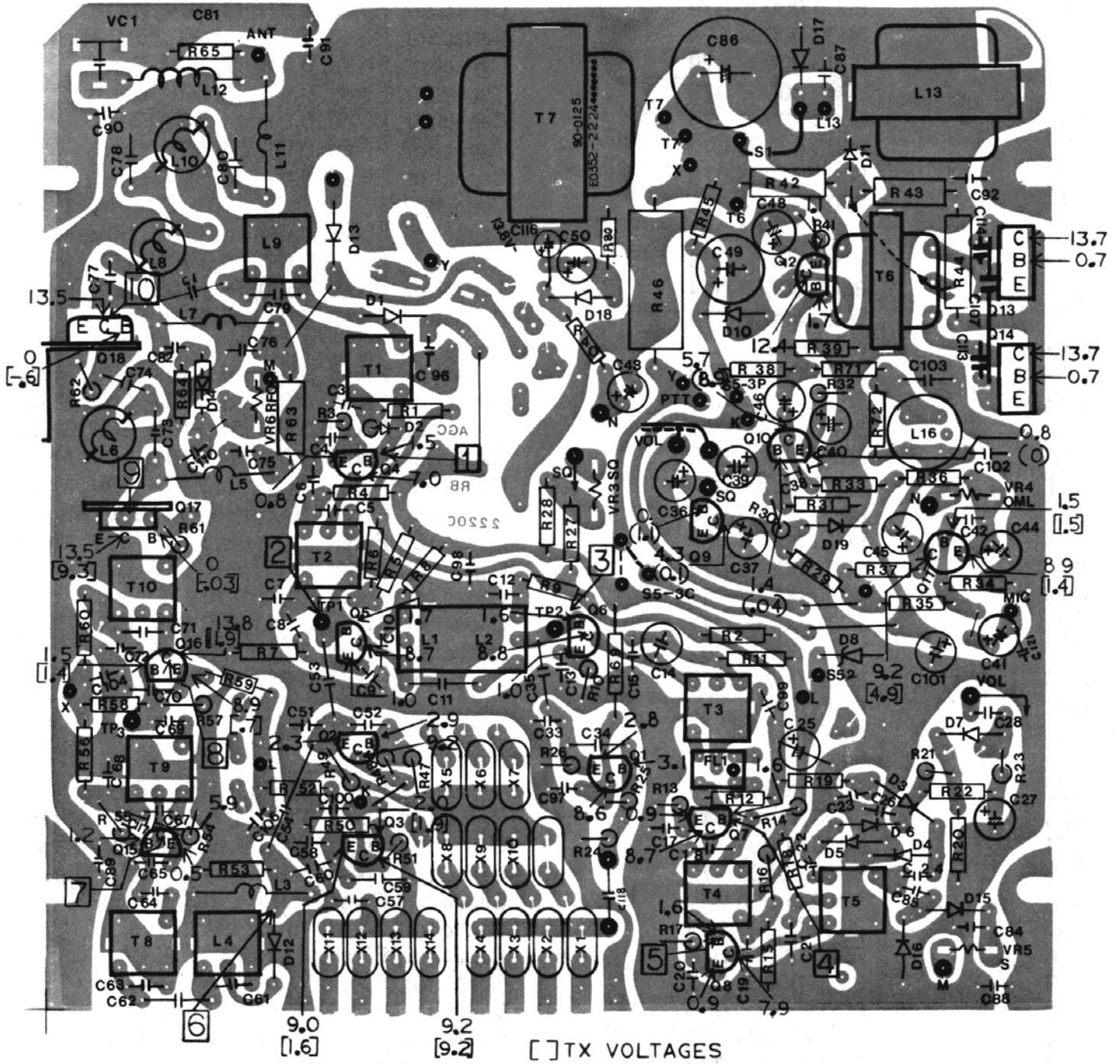

SBE-29CB CATALINA III PARTS LIST

<u>SYMBOL #</u>	<u>PART #</u>	<u>DESCRIPTION</u>
C1	8000-00004-016	Capacitor, Fixed, 20pfd, ±10%, 50V, Mica
C2	Not Used	
C3	8000-00006-079	Capacitor, Fixed, 0.01mfd, 50V, Cer.
C4	8000-00006-079	Capacitor, Fixed, 0.01mfd, 50V, Cer.
C5	8000-00004-024	Capacitor, Fixed, 30pfd, ±10%, 50V, Mica
C6	8000-00006-079	Capacitor, Fixed, 0.01mfd, 50V, Cer.
C7	8000-00006-079	Capacitor, Fixed, 0.01mfd, 50V, Cer.
C8	8000-00006-079	Capacitor, Fixed, 0.01mfd, 50V, Cer.
C9	8000-00006-079	Capacitor, Fixed, 0.01mfd, 50V, Cer.
C10	8000-00006-079	Capacitor, Fixed, 0.01mfd, 50V, Cer.
C11	8000-00004-028	Capacitor, Fixed, 1pfd, ±10%, 50V, Mica
C12	8000-00004-003	Capacitor, Fixed, 0.04mfd, ±10%, 50V, Mylar
C13	8000-00004-003	Capacitor, Fixed, 0.04mfd, ±10%, 50V, Mylar
C14	8000-00004-014	Capacitor, Fixed, 1500pfd, ±10%, 50V, Styrol
C15	8000-00006-079	Capacitor, Fixed, 0.01mfd, 50V, Cer.
C16	Not Used	
C17	8000-00004-003	Capacitor, Fixed, 0.04mfd, ±10%, 50V, Mylar
C18	8000-00004-003	Capacitor, Fixed, 0.04mfd, ±10%, 50V, Mylar
C19	8000-00004-003	Capacitor, Fixed, 0.04mfd, ±10%, 50V, Mylar
C20	8000-00004-003	Capacitor, Fixed, 0.04mfd, ±10%, 50V, Mylar
C21	8000-00004-003	Capacitor, Fixed, 0.04mfd, ±10%, 50V, Mylar
C22	8000-00004-020	Capacitor, Fixed, 100pfd, ±10%, 50V, Mica
C23	8000-00004-003	Capacitor, Fixed, 0.04mfd, ±10%, 50V, Mylar
C24	8000-00006-077	Capacitor, Fixed, 0.001mfd, 50V, Cer.
C25	8000-00006-065	Capacitor, Fixed, 10mfd, 16V, Elect.
C26	8000-00006-077	Capacitor, Fixed, 0.001mfd, 50V, Cer.
C27	8000-00011-002	Capacitor, Fixed, 2.2mfd, 16V, Elect.
C28	8000-00006-079	Capacitor, Fixed, 0.01mfd, 50V, Cer.
C29	Not Used	
C30	Not Used	
C31	Not Used	
C32	8000-00006-273	Capacitor, Fixed, 35pfd, ±10%, 50V, Mica
C33	8000-00004-041	Capacitor, Fixed, 150pfd, ±10%, 50V, Mica
C34	8000-00004-017	Capacitor, Fixed, 500pfd, ±10%, 50V, Mica
C35	8000-00006-272	Capacitor, Fixed, 5.6pfd, ±10%, 50V, Mica
C36	8000-00006-064	Capacitor, Fixed, 4.7mfd, 16V, Elect.
C37	8000-00006-063	Capacitor, Fixed, 1mfd, 16V, Elect.
C38	8000-00006-079	Capacitor, Fixed, 0.01mfd, 50V, Cer.
C39	8000-00006-063	Capacitor, Fixed, 1mfd, 16V, Elect.
C40	8000-00006-065	Capacitor, Fixed, 10mfd, 16V, Elect.
C41	8000-00006-292	Capacitor, Fixed, 0.47mfd, 16V, Elect.
C42	8000-00006-079	Capacitor, Fixed, 0.01mfd, 50V, Cer.
C43	8000-00006-064	Capacitor, Fixed, 4.7mfd, 16V, Elect.
C44	8000-00006-065	Capacitor, Fixed, 10mfd, 16V, Elect.
C45	8000-00006-063	Capacitor, Fixed, 1mfd, 16V, Elect.
C46	8000-00006-063	Capacitor, Fixed, 1mfd, 16V, Elect.
C47	Not Used	
C48	8000-00006-067	Capacitor, Fixed, 100mfd, 16V, Elect.
C49	8000-00006-164	Capacitor, Fixed, 220mfd, 16V, Elect.
C50	8000-00006-064	Capacitor, Fixed, 4.7mfd, 16V, Elect.

<u>SYMBOL #</u>	<u>PART #</u>	<u>DESCRIPTION</u>
C51	8000-00012-004	Capacitor, Fixed, 65pfd, $\pm 10\%$, 50V, Mica
C52	8000-00004-027	Capacitor, Fixed, 220pfd, $\pm 10\%$, 50V, Mica
C53	8000-00004-002	Capacitor, Fixed, 15pfd, $\pm 10\%$, 50V, Mica
C54	8000-00006-050	Capacitor, Fixed, 5pfd, $\pm 10\%$, 50V, Mica
C55	Not Used	
C56	Not Used	
C57	Not Used	
C58	8000-00004-020	Capacitor, Fixed, 100pfd, $\pm 10\%$, 50V, Mica
C59	8000-00004-017	Capacitor, Fixed, 500pfd, $\pm 10\%$, 50V, Mica
C60	8000-00004-016	Capacitor, Fixed, 20pfd, $\pm 10\%$, 50V, Mica
C61	8000-00004-007	Capacitor, Fixed, 10pfd, $\pm 10\%$, 50V, Mica
C62	8000-00006-277	Capacitor, Fixed, 1pfd, $\pm 10\%$, 50V, Gimic
C63	8000-00004-006	Capacitor, Fixed, 24pfd, $\pm 10\%$, 50V, Mica
C64	8000-00006-077	Capacitor, Fixed, 0.001mfd, 50V, Cer.
C65	8000-00006-079	Capacitor, Fixed, 0.01mfd, 50V, Cer.
C66	Not Used	
C67	8000-00004-006	Capacitor, Fixed, 24pfd, $\pm 10\%$, 50V, Mica
C68	8000-00006-079	Capacitor, Fixed, 0.01mfd, 50V, Cer.
C69	8000-00006-077	Capacitor, Fixed, 0.001mfd, 50V, Cer.
C70	8000-00006-079	Capacitor, Fixed, 0.01mfd, 50V, Cer.
C71	8000-00004-041	Capacitor, Fixed, 150pfd, $\pm 10\%$, 50V, Mica
C72	8000-00006-079	Capacitor, Fixed, 0.01mfd, 50V, Cer.
C73	8000-00004-006	Capacitor, Fixed, 24pfd, $\pm 10\%$, 50V, Mica
C74	8000-00004-020	Capacitor, Fixed, 100pfd, $\pm 10\%$, 50V, Mica
C75	8000-00006-079	Capacitor, Fixed, 0.01mfd, 50V, Cer.
C76	8000-00006-079	Capacitor, Fixed, 0.01mfd, 50V, Cer.
C77	8000-00006-079	Capacitor, Fixed, 0.01mfd, 50V, Cer.
C78	8000-00006-275	Capacitor, Fixed, 270pfd, $\pm 10\%$, 50V, Mica
C79	8000-00004-023	Capacitor, Fixed, 300pfd, $\pm 10\%$, 50V, Mica
C80	8000-00012-006	Capacitor, Fixed, 200pfd, $\pm 10\%$, 50V, Mica
C81	8000-00006-274	Capacitor, Fixed, 75pfd, $\pm 10\%$, 50V, Mica
C82	8000-00004-028	Capacitor, Fixed, 1pfd, $\pm 10\%$, 50V, Mica
C83	Not Used	
C84	8000-00004-003	Capacitor, Fixed, 0.04mfd, $\pm 10\%$, 50V, Mylar
C85	8000-00004-023	Capacitor, Fixed, 300pfd, $\pm 10\%$, 50V, Mica
C86	8000-00006-068	Capacitor, Fixed, 1000mfd, 16V, Elect.
C87	8000-00004-048	Capacitor, Fixed, 100pfd, Feed-thru
C88	8000-00004-012	Capacitor, Fixed, 0.047mfd, 50V, Cer.
C89	8000-00004-012	Capacitor, Fixed, 0.047mfd, 50V, Cer.
C90	8000-00004-012	Capacitor, Fixed, 0.047mfd, 50V, Cer.
C91	8000-00004-012	Capacitor, Fixed, 0.047mfd, 50V, Cer.
C92	8000-00004-012	Capacitor, Fixed, 0.047mfd, 50V, Cer.
C93	8000-00004-012	Capacitor, Fixed, 0.047mfd, 50V, Cer.
C94	Not Used	
C95	Not Used	
C96	8000-00006-079	Capacitor, Fixed, 0.01mfd, 50V, Cer.
C97	8000-00006-079	Capacitor, Fixed, 0.01mfd, 50V, Cer.
C98	Not Used	
C99	Not Used	
C100	8000-00006-079	Capacitor, Fixed, 0.01mfd, 50V, Cer.
C101	8000-00006-164	Capacitor, Fixed, 220mfd, 16V, Elect.
C102	8000-00006-276	Capacitor, Fixed, 0.047mfd, $\pm 10\%$, 50V, Mylar

<u>SYMBOL #</u>	<u>PART #</u>	<u>DESCRIPTION</u>
C103	8000-00004-018	Capacitor, Fixed, 0.1mfd, $\pm 10\%$, 50V, Mylar
C104	Not Used	
C105	8000-00006-079	Capacitor, Fixed, 0.01mfd, 50V, Cer.
C106	8000-00006-079	Capacitor, Fixed, 0.01mfd, 50V, Cer.
C107	8000-00006-079	Capacitor, Fixed, 0.01mfd, 50V, Cer.
C108	Not Used	
C109	Not Used	
C110	8000-00006-079	Capacitor, Fixed, 0.01mfd, 50V, Cer.
C111	Not Used	
C112	Not Used	
C113	8000-00006-079	Capacitor, Fixed, 0.01mfd, 50V, Cer.
C114	8000-00006-079	Capacitor, Fixed, 0.01mfd, 50V, Cer.
C115	8000-00004-017	Capacitor, Fixed, 500pfd, $\pm 10\%$, 50V, Mica
C116	8000-00006-065	Capacitor, Fixed, 10mfd, 16V, Elect.
C117	8000-00006-079	Capacitor, Fixed, 0.01mfd, 50V, Cer.
C118	8000-00004-017	Capacitor, Fixed, 500pfd, $\pm 10\%$, 50V, Mica
C119	8000-00006-079	Capacitor, Fixed, 0.01mfd, 50V, Cer.
C120	8000-00006-079	Capacitor, Fixed, 0.01mfd, 50V, Cer.
C121	8000-00006-079	Capacitor, Fixed, 0.01mfd, 50V, Cer.
CV1	8000-00004-204	Capacitor, Var., 10pfd, Max, Cer. Trimmer
D1	8000-00038-008	Diode, WG714
D2	8000-00006-007	Diode, 1N60
D3	8000-00006-007	Diode, 1N60
D4	8000-00006-007	Diode, 1N60
D5	8000-00006-007	Diode, 1N60
D6	8000-00006-007	Diode, 1N60
D7	8000-00004-064	Diode, 1S84
D8	8000-00011-043	Diode, BZ090
D9	Not Used	
D10	8000-00011-043	Diode, BZ090
D11	8000-00011-045	Diode, 1S1211
D12	8000-00006-281	Diode, 1S2473
D13	8000-00030-010	Diode, 1N4002
D14	8000-00006-007	Diode, 1N60
D15	8000-00006-007	Diode, 1N60
D16	8000-00006-007	Diode, 1N60
D17	8000-00030-010	Diode, 1N4002
D18	8000-00006-007	Diode, 1N60
D19	8000-00006-007	Diode, 1N60
FL-1	8000-00006-291	Ceramic Filter, LF-A8
L1	8000-00012-032	Transformer, IF, 42K-10
L2	8000-00012-032	Transformer, IF, 42K-10
L3	8000-00004-053	Choke Coil, 22 μ h
L4	8000-00012-023	HF Coil, 507SY1
L5	8000-00030-011	Choke Coil, 2.5 μ h
L6	8000-00006-285	HF Coil, S-18 (Violet)
L7	8000-00004-055	Choke Coil, 0.65 μ h
L8	8000-00030-017	HF Coil, S-18 (White)
L9	8000-00012-029	HF Coil, Z343QD

<u>SYMBOL #</u>	<u>PART #</u>	<u>DESCRIPTION</u>
L10	8000-00030-017	HF Coil, S-18 (White)
L11	8000-00011-016	Choke Coil, 0.22 μ h
L12	8000-00004-059	Choke Coil, 0.85 μ h
L13	8000-00011-022	Choke Coil, K-10
L14	Not Used	
L15	Not Used	
L16	8000-00006-284	Choke Coil, K-58
Q1	8000-00006-003	Transistor, 2SC710
Q2	8000-00006-003	Transistor, 2SC710
Q3	8000-00006-003	Transistor, 2SC710
Q4	8000-00006-003	Transistor, 2SC710
Q5	8000-00006-003	Transistor, 2SC710
Q6	8000-00006-003	Transistor, 2SC710
Q7	8000-00006-003	Transistor, 2SC710
Q8	8000-00006-003	Transistor, 2SC710
Q9	8000-00006-003	Transistor, 2SC710
Q10	8000-00006-003	Transistor, 2SC710
Q11	8000-00032-027	Transistor, 2SD187
Q12	8000-00006-003	Transistor, 2SC710
Q13	8000-00004-087	Transistor, 2SC1014
Q14	8000-00004-087	Transistor, 2SC1014
Q15	8000-00004-003	Transistor, 2SC710
Q16	8000-00004-003	Transistor, 2SC710
Q17	8000-00006-278	Transistor, 2SC495T
Q18	8000-00006-279	Transistor, 2SC1678
R44	8000-00006-271	Resistor, Fixed, 0.5 Ω , 1W, Oxide Film
R46	8000-00006-270	Resistor, Fixed, 200 Ω , 2W, \pm 10%, Carbon
RL1	8000-00030-022	Relay, HTC-12
T1	8000-00006-287	HF Coil, C360DD
T2	8000-00006-288	HF Coil, P362AT
T3	8000-00012-033	Transformer, 1F, A086AD
T4	8000-00012-034	Transformer, 1F, E1A 227B
T5	8000-00012-035	Transformer, 1F, E1A 146D
T6	8000-00004-119	Transformer, Input, A01A
T7	8000-00006-290	Transformer, Output, E-52
T8	8000-00012-024	HF Coil, 507S3Y
T9	8000-00006-286	HF Coil, C305BD
T10	8000-00006-289	HF Coil, C042DD
VR1	8000-00006-333	Resistor, Var., 10K Ω , D type, w/switch
VR2	8000-00006-283	Resistor, Var., 10K Ω , B type
VR3	8000-00004-097	Resistor, Var., 10K Ω , 2T, Trimmer
VR4	8000-00004-097	Resistor, Var., 10K Ω , 2T, Trimmer
VR5	8000-00004-093	Resistor, Var., 50K Ω , 2T, Trimmer
VR6	8000-00004-094	Resistor, Var., 100K Ω , 2T, Trimmer
X1	8000-00012-043	Crystal, 9.545 MHz, HC25/U
X2	8000-00012-044	Crystal, 9.555 MHz, HC25/U
X3	8000-00012-045	Crystal, 9.565 MHz, HC25/U

<u>SYMBOL #</u>	<u>PART #</u>	<u>DESCRIPTION</u>
X4	8000-00012-046	Crystal, 9.585 MHz, HC25/U
X5	8000-00012-047	Crystal, 16.965 MHz, HC25/U
X6	8000-00012-048	Crystal, 17.015 MHz, HC25/U
X7	8000-00012-049	Crystal, 17.065 MHz, HC25/U
X8	8000-00012-050	Crystal, 17.115 MHz, HC25/U
X9	8000-00012-051	Crystal, 17.165 MHz, HC25/U
X10	8000-00012-052	Crystal, 17.215 MHz, HC25/U
X11	8000-00012-053	Crystal, 10.000 MHz, HC25/U
X12	8000-00012-054	Crystal, 10.010 MHz, HC25/U
X13	8000-00012-055	Crystal, 10.020 MHz, HC25/U
X14	8000-00012-056	Crystal, 10.040 MHz, HC25/U
	8000-00006-319	Front Panel, Right Side
	8000-00006-320	Front Panel, Center
	8000-00006-321	Front Panel, Left Side
	8000-00006-324	Cabinet, Top
	8000-00006-325	Cabinet, Bottom
	8000-00006-334	Mounting Bracket
	8000-00006-326	Rubber Insulator
	8000-00006-115	Knob, Channel
	8000-00030-027	Knob, Volume & Squelch
	8000-00006-120	Channel Disk
	8000-00006-294	Heat Sink, Final
	8000-00006-295	Heat Sink, Driver
	8000-00006-327	Front Bezel
	8000-00004-260	Lamp Grommet
	8000-00006-335	Screws for Mounting Bracket
	8000-00006-090	Antenna Connector
	8000-00004-153	Microphone
	8000-00006-092	In Line Fuse Holder
	8000-00006-091	Fuse, 2A
	8000-00004-142	Lamp, 16V, 40ma
	8000-00006-332	Meter, A36
	8000-00006-088	External Speaker Jack
	8000-00006-298	Speaker
	8000-00004-070	Microphone Jack
	8000-00004-164	Microphone Plug
	8000-00006-328	Bracket for Relay
	8000-00004-157	Microphone Hook
	8000-00006-329	F.C.C. Label
	8000-00006-255	Rotary Switch, 24T
	8000-00006-116	Channel Window
	8000-00006-330	Display Box
	8000-00006-331	Styrofoam



SBE, INC.
220 AIRPORT BLVD.
WATSONVILLE, CA 95076