

LCMS-4



OWNER'S MANUAL



TABLE OF CONTENTS

Getting on the Air.....	page 2
Controls and Indicators.....	page 4
Operating Single Sideband.....	page 6
Installation.....	page 6
Interference Remedy Chart.....	page 11
Taking a CB Radio into Another Country.....	page 12
Ordering Parts.....	page 13
Component Location/Layout.....	page 13
Parts List.....	page 17
Specifications.....	page 25
Service.....	page 26
F. C. C. License.....	page 27
Warranty.....	page 28

THE CB STORY

The Citizens Band lies between the shortwave broadcast and 10-meter amateur radio bands, and was established by law in 1949. The Class D two-way communications service was opened in 1959. (CB also includes a Class A business band and Class C remote-control frequencies.) Acquiring the Class D license requires no detailed technical or Morse-code knowledge that is required for a "Ham" license.

FREQUENCY RANGE

The LCMS-4 transceiver represents one of the most advanced SSB/AM two-way radios ever designed for use as a Class D station in the Citizens Radio Service. This unit features advanced Phase Lock Loop (PLL) circuitry, which is used in the AM mode and in the upper and lower single sideband modes, providing complete coverage of all 40 channels shown below.

Channel	Channel Frequency in MHz	Channel	Channel Frequency in MHz
1	26.965	21	27.215
2	26.975	22	27.225
3	26.985	23	27.255
4	27.005	24	27.235
5	27.015	25	27.245
6	27.025	26	27.265
7	27.035	27	27.275
8	27.055	28	27.285
9	27.065	29	27.295
10	27.075	30	27.305
11	27.085	31	27.315
12	27.105	32	27.325
13	27.115	33	27.335
14	27.125	34	27.345
15	27.135	35	27.355
16	27.155	36	27.365
17	27.165	37	27.375
18	27.175	38	27.385
19	27.185	39	27.395
20	27.205	40	27.405

F. C. C. LICENSE

The LCM-S-4 transceiver is type accepted by the Federal Communications Commission, for operation on any of the 40 Citizens Band channels. You are required to read and understand Part 95 of the F.C.C. regulations prior to operation of this unit. A copy of Part 95 is enclosed.

You must obtain a Class D station license before transmitting. If you do not have a license, obtain one with the enclose application Form 505. You may operate under a temporary permit for 60 days after the Form 505 is mailed to the F.C.C. provided that you complete and comply with the enclosed Temporary Permit, Form 555-B.

WARNING: Transmitter section adjustments must be performed by a qualified technician holding a valid First or Second class F.C.C. radiotelephone license.

The use of substitute components in the transmitter section of this equipment may cause a violation of F.C.C. rules and regulations. Use only the exact replacement parts specified in the parts list with this instruction manual.

GETTING ON THE AIR

You must have an F.C.C. license to operate this unit. If you do not presently have one, consult the last page of this instruction manual. You may start operating under a temporary license as soon as the enclosed Form 505 is mailed. If your LCM-S-4 is already installed, you may proceed immediately to the next section — OPERATING INSTRUCTIONS. For those who prefer to do their own installation, detailed installation instructions are included.

OPERATING INSTRUCTIONS

Receive:

1. Set the CB/PA switch to CB, the NL/SSB to ON and the NB switch to off.
2. Turn the OFF/VOLUME control clockwise. The S/RF meter and CHANNEL INDICATOR should illuminate.

3. Turn SQUELCH control fully counterclockwise.
4. Adjust VOLUME control until a hissing sound or voice conversation is heard at a comfortable level.
5. Slowly turn SQUELCH control clockwise until the hissing sound just disappears or until unintelligible weak signals are eliminated.
6. Rotate CHANNEL SELECTOR knob until a channel with CB traffic is found.
7. Set MODE SWITCH on mode (AM, USB, LSB) that produces intelligible reception.
8. Adjust CLARIFIER.
9. Readjust SQUELCH control until unwanted weak signals are eliminated.

Transmit:

- You must have a Class D station license before transmitting. All channels, except channel 9, may be used for normal communications. Channel 9 has been reserved by the FCC for emergency communications, such as protection of property of assistance to a motorist.
1. Select desired channel: listen and when clear, press PTT button. Tx light will come on, and S/RF meter will show output power.
 2. Hold the microphone close to your mouth and speak clearly.
 3. Release the PTT button and listen for a reply.

CONTROLS AND INDICATORS



Control Functions:

1. **OFF/ON VOLUME** — Turn ON/OFF Volume control clockwise to apply power to the unit and to set the desired listening level.
2. **SQUELCH** — The Squelch control blanks out unwanted noise when no signals are present. Turn this control fully counter-clockwise then slowly clockwise until the receive noise disappears. Any signal to be received must now be slightly stronger than the average received noise. Further clockwise rotation will increase the threshold level which a signal must overcome in order to be heard. Only strong signals will be heard at the maximum clockwise setting.
3. **CLARIFIER** — The Clarifier permits variation of the receiver operating frequencies above and below the assigned frequencies. Although this control is intended primarily to tune in SSB signals, it may be used to optimize AM signals as described in the operating procedure paragraphs.
4. **CHANNEL SELECTOR** — Selects the desired channel for transmission and reception. All channels, except channel 9, may be used between units operating under the same license. Channel 9 has been reserved by the F.C.C. for emergency communications or immediate protection of property. Channel 9 may also be used to render assistance to a motorist; it is commonly called the **HELP** channel.
5. **CHANNEL INDICATOR** — LED display indicates the channel on which the unit is operating.
6. **MODE SWITCH** — The Mode Switch selects either of the SSB modes (USB or LSB) or standard double sideband AM. Unless the station with which communications is desired is equipped with SSB, the AM mode is normally used. The mode selector switch changes the mode of operation of both transmitter and receiver simultaneously. An explanation of how to determine which mode to use is contained in the following paragraphs under Operating Procedure.
7. **NOISE BLANKER SWITCH** — In addition to having a series gate noise limiter, the LCMS-4 is equipped with a deluxe noise blanker which operates in both AM and SSB modes of operation. The noise blanker has no effect on receiver fidelity but instead has the effect of enhancing receiver performance by the reduction of incoming atmospheric/ignition noise. During mobile operation, the NB switch will normally be left in the ON or NB position to reduce ignition noise.
8. **PA/CB SWITCH** — The PA/CB Switch determines whether the unit operates in CB or PA mode. The PA function should not be used unless an external speaker is connected as described in the installation section of this manual. In the CB position, the PA is disabled and the unit will transmit and receive on the selected frequencies. If a PA speaker is connected and the PA/CB switch is placed in the PA position, normal receiver audio will be heard on the PA speaker.
9. **NL/OFF SWITCH** — The NL/OFF Switch greatly reduces extraneous noise coming into the receiver via the antenna. The noise pulses are clipped from the incoming signals before they reach the audio amplifier. This causes little or no loss in the signal receive level. The switch has been provided for elimination and control of this circuit.
10. **METER** — The meter indicates received signal and transmitter output strength in both AM and SSB modes of operation.
11. **TX LIGHT** — Indicates power out of the transmitter.
12. **EXTERNAL SPEAKER** — The external speaker jack provides connection for a 4 or 8 ohms external speaker. The speaker should have a power rating of at least 4 watts. The LCMS-4's

internal speaker will be disabled when an external speaker is connected.

13. PA — The PA jack provides connection for a 4 or 8 ohms, 4 watt speaker so that the LCMS-4 may be used as a public address system.

OPERATING SINGLE SIDEBAND

There are three types of signals presently used in CB communication — AM (Amplitude modulation), and the two types of SSB (Single Sideband) signals — LSB (Lower Sideband) and USB (Upper Sideband). The LCMS-4 is capable of receiving and transmitting any of these signals. A SSB signal (either USB or LSB) may be recognized while in AM mode by its characteristic garbled sound. A SSB signal can only be received by a receiver operating in the same mode.

To receive a SSB signal, switch to either LSB or USB. If you are in the correct sideband mode, turning the CLARIFIER knob will make the signal intelligible. If you are in the wrong sideband mode, no amount of turning of the CLARIFIER knob will make the signal intelligible.

Single sideband has several advantages over AM. In AM transmission, at least two-thirds of the power is expended to produce the carrier while all of the power in SSB goes to produce only one sideband — the only part of the transmission conveying intelligence. Since only one sideband is produced, only half of a channel is used. Also, flutter effects often caused by vehicle motion are substantially reduced. Because of these advantages, Range Ratings of sideband radios are 2 to 3 times greater than AM radios at full modulation. Since single sideband gives greater range to more people, special channels are extended to Sidebanders through CB courtesy.

INSTALLATION

A good installation is the most important factor in achieving maximum performance from your LCMS-4. Complete installation service is available from many CB radio dealers. While no special tools are needed for installation, the antenna installation should be checked

with a good quality VSWR meter. If you do your own installation and do not have access to a VSWR meter, it is recommended that you have the installation checked by a local CB radio dealer.

PERMANENT INSTALLATION

Choose a convenient location for your LCMS-4. Usually, this is under the dash, but the LCMS-4 may be mounted in any position on a rigid surface. Check to be sure that the radio is not in the direct airstream of the vehicle's heater and that there is sufficient space behind the radio for antenna and accessory cable connections. Make certain that the microphone is easily accessible. The microphone holder may be mounted either on the side of the radio where convenient holes are provided or on any rigid surface.

Attach the bracket to the radio and hold the unit against the planned mounting surface. Draw around the bracket so as to leave an outline on the mounting surface. Check to be sure that holes drilled through the mounting surface to secure the bracket will not damage any of the vehicle's components. Find a clear, accessible path between the antenna and radio mounting locations. Remove the antenna cable from the antenna's packing. Snake the cable along the intended path. Tie or tape the excess cable into a neat roll and tuck into a concealed space. Install the antenna according to the manufacturer's instructions. Detach the bracket from the radio place into the outline and mark and center punch screw holes. Drill 7/32" clearance. To insure that the drill will not punch through and damage any part of the vehicle, wind a few turns of tape about 1/2 inch from the tip of the drill bit. Mount bracket and then mount radio.

Before wiring your LCMS-4 to power, check the ground polarity of your vehicle by consulting the owner's manual or observing which battery terminal is connected to the vehicle's chassis. An additional LCMS-4 amp fuse and holder must be wired into the negative (black) power lead in positive ground vehicles. The LCMS-4 may be connected to the accessory side of the ignition switch. If this connection proves to be too noisy, direct connection to the battery is recommended.

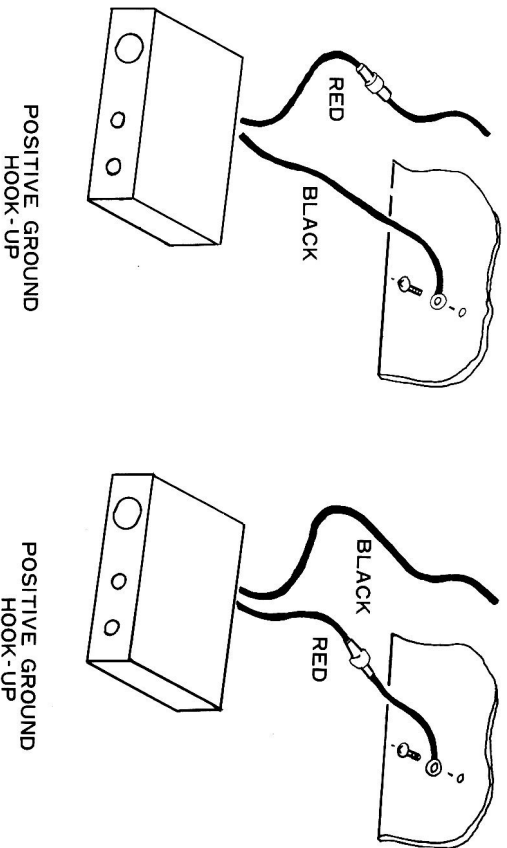

ANTENNA TUNING

The final step in installation is to trim the antenna for minimum S.W.R. The recommended method of antenna tuning is to use an in-line wattmeter or S.W.R. bridge to adjust the antenna for minimum reflected power on channel 20. A properly tuned antenna system will present a suitable load to the transceiver and will insure that maximum power is transferred from the radio to the antenna. If the antenna system in use presents a poor load, as indicated by a high S.W.R. reading, transmitter range will be substantially reduced and damage to the transmitter final amplifier may occur. Poor S.W.R. can usually be corrected by altering the antenna's electrical length in accordance with the manufacturer's instruction. Extremely high S.W.R. readings may be indicative of a defective transmission line, antenna, or connections.

To determine whether the antenna should be lengthened or shortened, test the S.W.R. on channels 1 and 40. If the S.W.R. is the highest on channel 40 the antenna is too long and if highest on channel 1, the antenna is too short. When the antenna system has been tuned correctly, channel 20 should have the lowest S.W.R. and channels 1 and 40 will be slightly higher.

PUBLIC ADDRESS

An external 8 ohm 4 watt speaker may be connected to the PA jack located on the rear panel of the unit when it is to be used as a public address system. The speaker should be directed away from the microphone to prevent acoustical feedback.

ALTERNATE MICROPHONE & INSTALLATION

For best results the user should select a low impedance dynamic type microphone or a transistorized preamplified microphone. Wiring connections for the alternate microphones are shown in Figure 1 below.

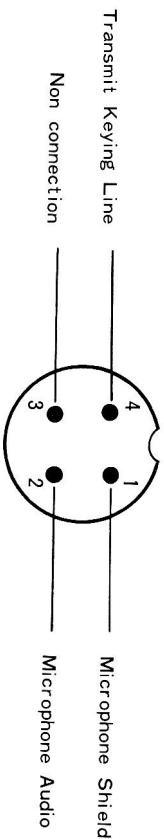

FIGURE 1
MICROPHONE JACK WIRING DIAGRAM
REAR VIEW

FINAL CHECKOUT

Make an operational checkout of the transceiver to insure operation of it and all the accessories installed. Contact other stations and inquire about their location and their reception of your signal. If an omnidirectional antenna is used, the distance to other stations contacted should be about the same in all directions. A directional antenna should reach more distant stations in the direction in which it is beamed. Also inquire whether the stations contacted are omnidirectional or directional and if directional which way they are beamed.

CHOOSING AN ANTENNA

The type of antenna and mounting location determines the direction and range of communication. A CO-PHASE antenna gives maximum range to the front and rear of the vehicle and is best suited for communicating with distant vehicles traveling on the same straight highway. A single antenna mounted on the center of the vehicle gives the best range in all directions and is best suited for city or general

purpose communication. A single antenna will be directional when mounted away from the center of the vehicle Figure 2 shows a method for determining the direction.

ANTENNA MOUNTING LOCATION

The best antenna location in most vehicles is the center of the passenger compartment roof. The trunk is a satisfactory location, especially if it is large and flat. Due to ignition noise, the antenna should not be mounted over the engine compartment. Various types of clamp-on antennas are available for temporary mounting on side mirrors, luggage racks, rain gutters and bumpers. These antennas permit the antenna cable to be dressed through vents, side windows, or under the vehicle without drilling holes. A permanent antenna should be mounted in a location that permits dressing the antenna cable through the vehicle's frame or under its upholstery.

FIGURE 2 Determining Antenna Range Direction

Before installing an antenna, an approximation of the direction of maximum range can be obtained by following these rules.

1. Draw a rough silhouette of the vehicle as seen from above.
2. Place a small X in the approximate center of the silhouette.
3. Place a dot on the silhouette where a single antenna is planned, or if a co-phase is to be used, draw a line connecting the antennas. Place dot in the center of this line.
4. Draw a line from the dot through the X. This line will point in the predominant direction. The longer the distance between the X and the dot the more predominant will be the range in that direction. A single antenna placed on the X will communicate equally in all directions. If the line connecting co-phase antennas intersects the X, the predominant direction will be in both directions perpendicular to the line.

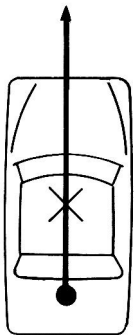

TRUNK MOUNT

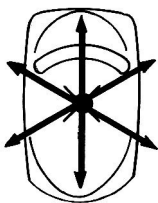

PASSENGER COMPARTMENT MOUNT

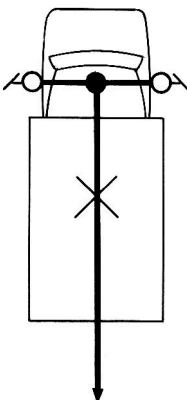

CO-PHASE MIRROR MOUNT

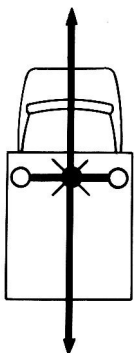

CO-PHASE SIDE MOUNT

INTERFERENCE REMEDY CHART

TYPE OF INTERFERENCE	CAUSE	REMEDY
POPPING — increases rate with engine speed. Stops instantly when ignition is shut off.	Ignition	Make certain that engine is properly tuned. Install resistor plug with suppressor cable if vehicle does not already have them.
WHINE — goes up with engine speed. Whines down when ignition is shut off.	Generator or Alternator	Clean commutator or slip rings. Check brushes.
POPPING OR RUSHING — occurs in dry weather at high speeds.	Wheels and Tires	Install static collector rings in front wheel caps or put antistatic powder in inner tube or tire.
NOISE — occurs when accessory is turned on.	Accessory	Install 0.25 MFD capacitor across power terminals at accessory.
CRACKLING, CLICKING — occurs as gauges operate or dash is jarred.	Gauge or Voltage Limiter	Clip 0.25 MFD capacitor across gauges and voltage limiter until interference disappears. Install capacitor at that point.

TAKING A CB RADIO INTO ANOTHER COUNTRY

Since laws change, always check with a country's Consul General's Office before taking a CB radio into that country. Many countries do not presently offer CB service while others do not offer it on the same frequencies. The CB frequencies used in the United States and Canada are used by some countries for government and commerce.

Persons holding valid U.S. Citizens Band licenses or temporary permits may obtain authority to operate in Canada by requesting D.O.C. Form "APPLICATION FOR REGISTRATION OF RADIO STATION LICENSEE OF UNITED STATES OF AMERICA" from a Canadian consulate and mailing it in at least 60 days prior to entry into Canada. Canadians planning to travel in the United States could obtain F.C.C. Form 410-B, "APPLICATION FOR PERMIT TO OPERATE A CANADIAN GENERAL RADIO SERVICE STATION IN THE UNITED STATES."

Mexico does not have a Citizens Band service. It is against the law to take a Citizens Band transceiver into Mexico.

TOP VIEW

PARTS LAYOUT

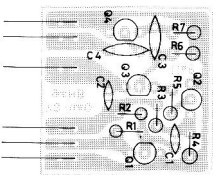
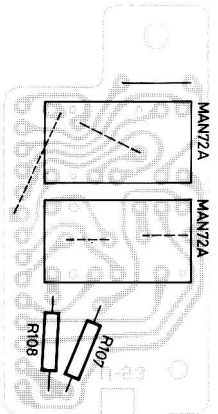
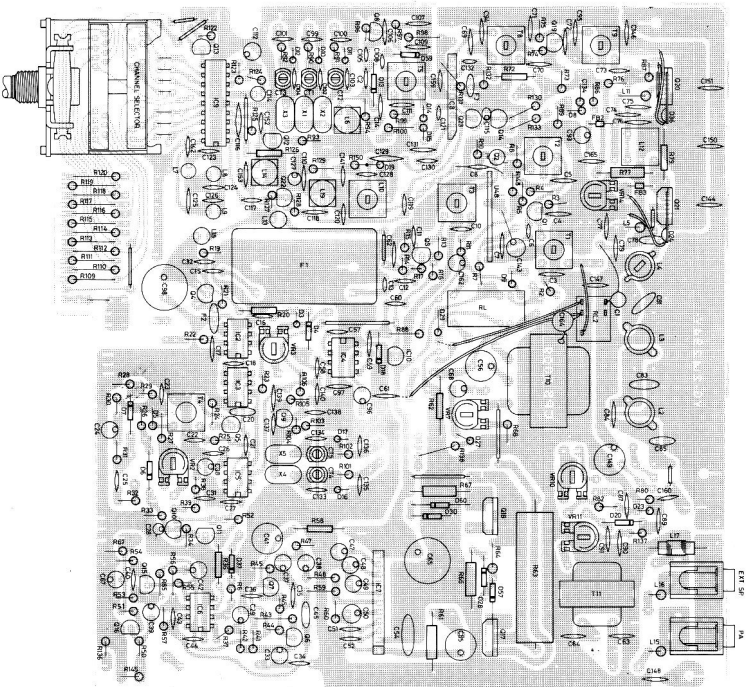

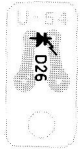
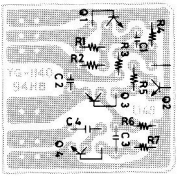
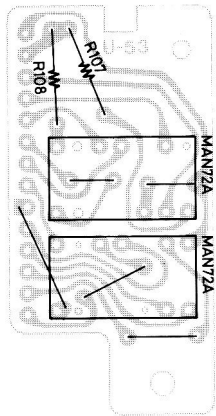
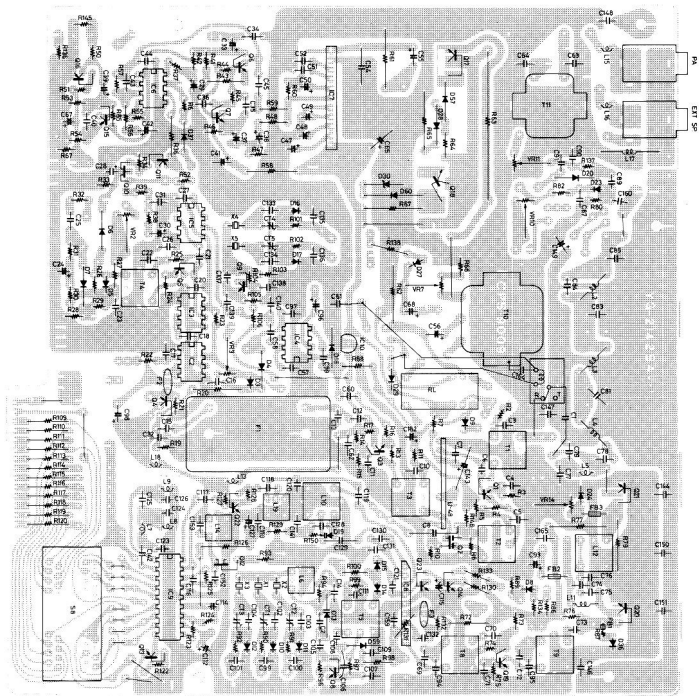

BLOCK DIAGRAM

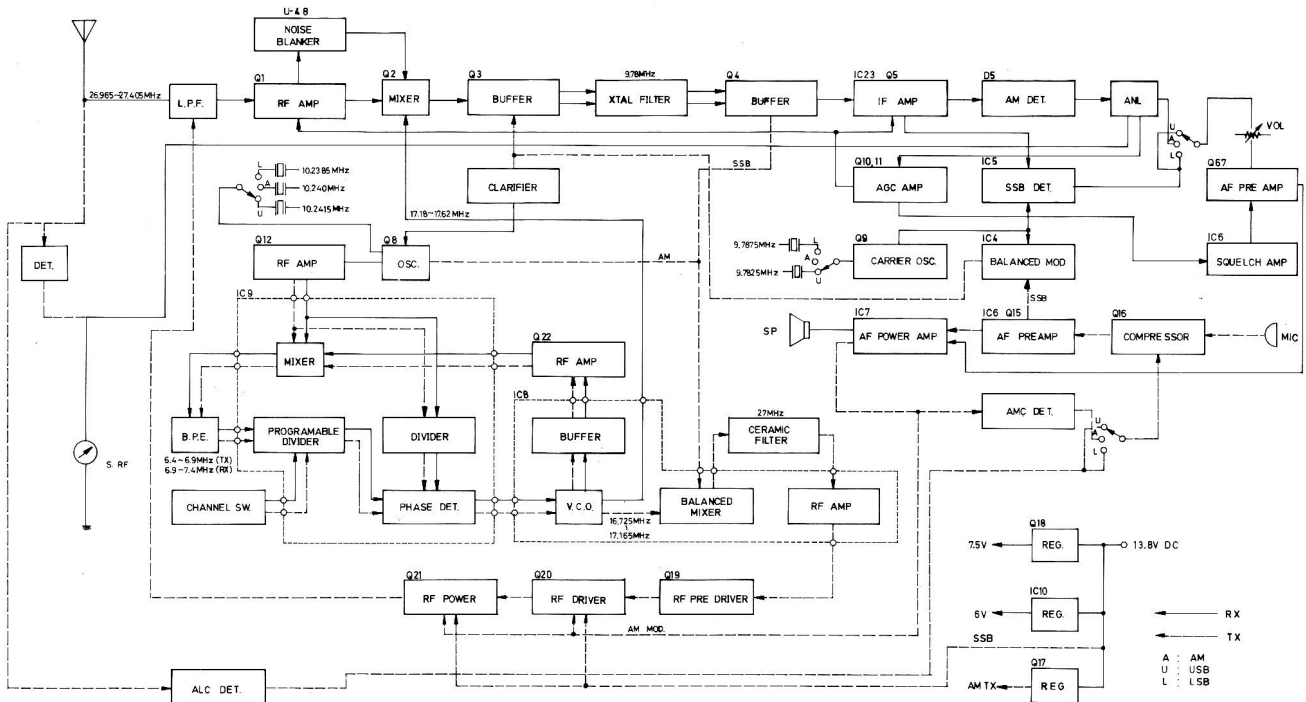

WIRING DIAGRAM

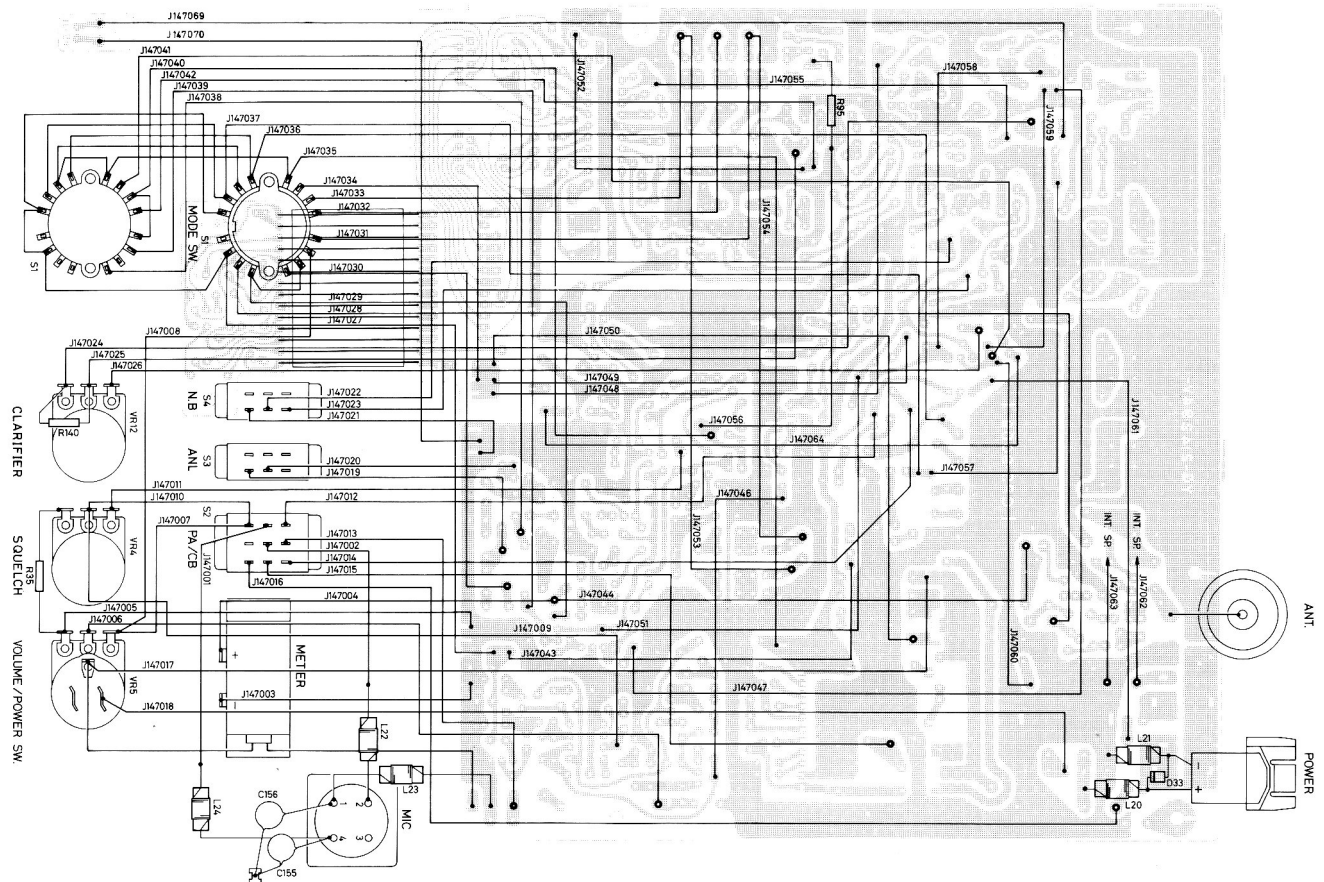

LCMS-4 CB PARTS LIST

Parts No.	Description	Qty	SBE Part Number
SL1612C	I. C.	2	8000-00059-001
SL1640C	" "	2	8000-00047-001
AN103	" "	1	8000-00059-002
AN315	" "	1	8000-00059-003
NJM78L06A	" "	1	8000-00047-006
MC1458	" "	1	8000-00059-004
CC13001	" "	1	8000-00059-005
3SK45	FET	1	8000-00042-013
2SK49(H)	" "	1	8000-00059-006
2SK107-4	" "	1	8000-00059-007
2SA673(C)	Transistor	1	8000-00059-008
2SB61(B)	" "	1	8000-00059-009
2SC945(O)	" "	6	8000-00041-042
2SC710(C)	" "	1	8000-00011-047
2SC829(B)	" "	4	8000-00024-055
2SC945(R)	" "	1	8000-00041-041
2SC1061(C)	" "	1	8000-00011-050
2SC1419(C)	w/ Mica	1	8000-00059-010
2SC1856	" "	1	8000-00059-011
2SC2003(L)	" "	1	8000-00059-012
2SC2166	w/ Mica	1	8000-00049-060
2SC2312	w/ Mica	1	8000-00059-013
S3V-10	Diode	1	8000-00059-014
W06B or W06C	" "	2	8000-00059-015
1S2075K	" "	1	8000-00059-016
1S2076 or 1S953	" "	6	8000-00059-017
1S2588	" "	7	8000-00059-018
1TT-73C	" "	7	8000-00059-019
IN60P	" "	1	8000-00006-007
IN60P-1(FM1)	" "	1	8000-00038-009

Parts No.	Description	Q'ty	SBE Part Number
1S2687T	Var-Cap	1	8000-00059-020
1S2689	"	1	8000-00059-021
MV1Y	Varistor	2	8000-00059-022
MV11YM	"	1	8000-00059-023
WZ-075	Zener Diode	1	8000-00059-024
MANZ2A	LED	2	8000-00059-025
LN28RP	"	1	8000-00059-026
CP-S-3024	Crystal Oscillator 10.2385 MHz	1	8000-00059-027
CP-S-3025	" 10.2400 MHz	1	8000-00059-028
CP-S-3026	" 10.2415 MHz	1	8000-00059-029
CP-S-3012	" 9.7875 MHz	1	8000-00059-030
CP-S-3013	" 9.7825 MHz	1	8000-00059-031
CP-S-4006	Crystal Filter 9.785 MHz	1	8000-00059-032
SFE-9.8MA	Ceramic Filter	1	8000-00059-033
EFO-S27MT1	"	1	8000-00059-034
ETT-1002	Choke Transformer	1	8000-00059-035
CP-S-2001	Matching Transformer	1	8000-00059-036
AW6221	Relay	1	8000-00059-037
MZ-12	"	1	8000-00059-099
SJ-707	Phone Jack	2	8000-00059-038
FSS214-4SS(G2)	Mike Terminal	1	8000-00004-070
FM-MR-M2	Antenna Terminal	1	8000-00059-039
9V-80mA	Lamp (Clear)	1	8000-00059-040
SR92-14	Speaker	1	8000-00059-041
4H-2018 w/Holder	Meter	1	8000-00059-042
MO43D50N1310	Mike	1	8000-00059-043
ETV-70041	Variable Resistor	1	8000-00030-003
ETV-70040	"	2	8000-00030-002
ETS-147082	Slide Switch	1	8000-00059-044
ETS-147081	"	2	8000-00059-045
ETS-83059	rotary Switch	1	8000-00059-046

Parts No.	Description	Q'ty	SBE Part Number
CP-S-5002	Rotary Switch	1	8000-00059-047
CV05D180	Ceramic Trimmer	5	8000-00059-048
FR085-200 ohm	Semi-Fixed Resistor	1	8000-00059-049
FR085-10K ohm	"	4	8000-00059-050
FR085-20K ohm	"	1	8000-00059-051
1-480359-0	Power Socket	1	8000-00059-052
1-480360-0	Power Plug	1	8000-00059-053
ETOA-002-03	Power Cord, Fuse-Holder	1 kit	8000-00041-087
3A 125V	Fuse	1	8000-00011-078
JPS-14-0-1-25-3.5	P. C. Joiner	1	8000-00059-054
LF4-010K	Micro Inductor	2	8000-00058-035
LF1-220K	"	3	8000-00006-262
3.5φ x1.3φ x3m/m	Ferrite Beads	2	8000-00059-055
3.5φ x1.3φ x6m/m	"	1	8000-00059-056
SP0410-3R3K1R5	Choke Coil	10	8000-00059-057
ETC-15062	Coil	2	8000-00059-058
ETC-15063	"	2	8000-00059-059
ETC-20107	"	1	8000-00059-060
ETC-20113	"	1	8000-00059-061
ETC-1093	"	2	8000-00059-062
CP-S-1020	"	1	8000-00059-063
CP-S-1021	"	1	8000-00059-064
CP-S-1018	"	1	8000-00059-065
ETC-123216	"	1	8000-00059-066
CP-S-1023	"	1	8000-00059-067
ETC-147225	"	1	8000-00059-104
ETC-147227	"	1	8000-00059-101
CP-S-9009	P. C. B. (Main)	1	8000-00059-068
U-53	" (CH, LED)	1	8000-00059-102
U-54	" (TX, LED)	1	8000-00059-103

Parts No.	Description	Q'ty	SBE Part Number
0.022 μ F/K 50V	Mylar Condenser	1	3-.022M50-1
0.068 μ F/K 50V	"	1	3-.068M50-1
0.1 μ F/M 50V	"	2	3-.1M50-1
0.22 μ F/M 50V	"	1	3-.22M50
0.47 μ F 16V	Tantalum Condenser	1	8000-00059-069
22 μ F 10V	"	1	8000-00059-070
1 μ F 10V	"	1	8000-00047-017
0.22 μ F 10V	"	1	8000-00047-018
120 μ F 50V	Silvered Mica Condenser	1	2-120P50-1
330 μ F 50V	"	1	2-330P50-2
390 μ F 50V	"	1	2-390P50
0.1 μ F 50V	Electrolytic Condenser	1	4-.1M50
0.47 μ F 50V	"	2	4-.47M50
1 μ F 50V	"	7	4-1M50-1
2.2 μ F 50V	"	1	4-2.2M50
4.7 μ F 25V	"	1	4-4.7M25-1
10 μ F 16V	"	6	4-10M16-1
33 μ F 16V	"	1	4-33M16-1
100 μ F 16V	"	1	4-100M16-2
220 μ F 16V	"	2	4-220M16-2
330 μ F 16V	"	1	4-330M16-2
1000 μ F 16V	"	1	4-1000M16-2
2200 μ F 16V	"	1	4-2200M16-2
5pF SL	Ceramic Condenser	1	1-5P50-SL
7pF NP0	"	1	1-7P50-NP0
15pF NP0	"	2	1-15P50-NP0
33pF N220	"	3	1-33P50-N220
33pF N470	"	1	1-33P50-N470
47pF N750	"	3	1-47P50-N750
56pF NP0	"	1	1-56P50-NP0
68pF N220	"	2	1-68P50-N220
68pF SL	"	1	1-68P50-SL
100 μ F N220	"	1	1-100P50-N220
100 μ F SL	"	2	1-100P50-SL
100 μ F N750	"	1	1-100P50-N750
120 μ F N220	"	3	1-120P50-N220

Parts No.	Description	Q'ty	SBE Part Number
150 μ F N750	Ceramic Condenser	3	1-150P50-N750
180 μ F N220	"	1	1-180P50-N220
220 μ F N750	"	2	1-220P50-N750
56 μ F N220	"	1	1-56P50-N220
470 μ F B	"	4	1-470P50-B
560 μ F B	"	1	1-560P50-B
1000 μ F D	"	20	1-1000P50-D
1800 μ F B	"	1	1-1800P50-B
2200 μ F B	"	2	1-2200P50-B
3300 μ F D	"	1	1-3300P50-D
0.01 μ F B	"	17	1-.01M50-B
0.0 μ F F,Y	"	19	1-.01M50-F-Y
0.022 μ F F,Y	"	12	1-.022M25-F-Y
0.039 μ F F,Z	"	1	1-.039M50-F-Z
0.1 μ F F,Z	"	3	1-.1M50-F-Z
0.0047 μ F B	"	2	1-.0047M50-2
68pF	"	1	1-68P50
27pF	"	1	1-27P50
5pF	"	1	1-5P50
7W 100hmK	Cement Resistor	1	8000-00059-071
150 ohm $\frac{1}{2}$ W	Carbon Resistor	1	
180 ohm "	"	3	
220 ohm "	"	2	
22 ohm $\frac{1}{4}$ W	Carbon Resistor	1	
33 ohm "	"	1	
47 ohm "	"	2	
100 ohm "	"	7	
220 ohm "	"	1	
270 ohm "	"	3	
330 ohm "	"	6	
470 ohm "	"	4	
560 ohm "	"	1	
680 ohm "	"	3	

Parts No.	Description	Q'ty	SBE Part Number
1K ohm	Carbon Resistor	8	
1.2K ohm	"	1	
1.5K ohm	"	1	
2.2K ohm	"	1	
3.3K ohm	"	6	
4.7K ohm	"	3	
5.6K ohm	"	2	
6.8K ohm	"	1	
10K ohm	"	10	
15K ohm	"	1	
22K ohm	"	2	
27K ohm	"	1	
33K ohm	"	2	
47K ohm	"	7	
82K ohm	"	1	
100K ohm	"	2	
120K ohm	"	1	
150K ohm	"	3	
180K ohm	"	1	
220K ohm	"	1	
1M ohm	"	1	
2.2M ohm	"	2	
820 ohm	"	1	
68 ohm	"	1	
330 ohm	"	1	
680 ohm	"	14	
1.2K ohm	"	1	
2.2K ohm	"	1	
4.7K ohm	"	1	
5.6K ohm	"	2	
10K ohm	"	2	
33K ohm	"	1	
25C1675(L)	Transistor	2	8000-00041-046
25A733(Q)	"	1	8000-00059-072
25C945(P)	"	1	8000-00059-073

Parts No.	Description	Q'ty	SBE Part Number
1K ohm	Carbon Resistor	2	
2.7K ohm	"	1	
3.3K ohm	"	2	
47K ohm	"	1	
68K ohm	"	1	
1000pF	Ceramic Condensator	2	1-1000P50-1
2200pF	"	1	1-2200P50
0.01uF	"	1	1-.01M50-1
U-48	P. C. B. (N. B.)	1	8000-00059-074
4-AMP1002	Print Terminal	6	8000-00059-075
	Cord Unit	1 kit	
2147001-0	Front Panel	1	8000-00059-076
2147002-0	Main Chassis	1	
4147003-0	Sub Chassis	1	8000-00059-077
4147004-0	Logo Plate	1	8000-00059-078
4147005-0	Channel Plate	1	8000-00059-079
3147006-0	Control Plate	1	8000-00059-080
3147007-1	Channel Knob	1	8000-00059-081
3147008-0	Control Knob	4	8000-00059-082
2147009-0	Case Top	1	8000-00059-083
2147010-0	Case Bottom	1	8000-00059-084
3147011-0	Mounting Bracket	1	8000-00059-085
4147012-0	FCC Plate	1	8000-00059-086
4147013-0	Display Box	1	8000-00059-087
4100007	Heat Sink P	1	8000-00059-088
4100008	" " Q	1	8000-00059-089
4100009	" " R	1	8000-00059-090
4-10022	Mic Hanger	1	8000-00004-157
4-83022	BK Spacer A	3	8000-00059-092
4-83017	Insulating Bush	2	8000-00059-093
4-84015	Wool Paper	2	8000-00059-094

Parts No.	Description	Q'ty	SBE Part Number
4-70024	Insulating Plate for IC	1	8000-00059-095
5200	Knob Spring	1	8000-00059-096
	Small Screw + Bind M3 x 6	4	
	" " + " M4 x 4	4	
	" " + Pan M2 x 4	6	
	" " + Pan M3 x 8	2	
	" " + Plate M3 x 6	4	
	Tapping Pin + Pan M3 x 8	12	
	" " + Pan M5 x 10	5	
	Poly-Sulfone Screw M3 x 8	4	
	SEMS Screw M3 x 8	2	
	Hexagon Bolt M4 x 8 Ni-3	4	
	Hexagon Nut M2.6	2	
	" " M4	4	
	Lock Washer M5	5	
	Spring Washer M2.6	2	
	" " M3	4	
	Small Screw + Pan M2.6 x 4	1	
	" " + Pan M3 x 6	1	
MA420	Blind Rivet	2	
	Black Speaker Screw		8000-00059-097
	Black Cabinet Screw		8000-00059-098
	Mounting Bracket Bolt		8000-00059-099

SPECIFICATIONS

GENERAL

Channels	: 40
Frequency Range	: 26.965 to 27.405 MHz
Frequency Control	: Single Crystal, Digitally synthesized
Frequency Stability	: 0.005 %
Operating Temperature Range	: -30°C to +50°C
Humidity	: 95 %
Microphone	: Dynamic w/p.t.t. switch and coil cord
Input Voltage	: 13.8 VDC positive or negative ground. 15.9 VDC maximum, 11.7 VDC minimum
Current Drain	: Transmit: AM 95% mod. Carrier 1.8 amps SSB 12 watts PEP output 2.5 amps
Antenna Connector	: Receive: Squelched 0.25 amp 2 watt audio output 0.5A
	: UHF, SO-239

TRANSMITTER

Power Output	: AM: 4 watts SSB: 12 watts
Modulation	: AM, high and low level Class A
Modulation Capability	: AM, 100 %
Intermodulation Distortion	: SSB: 3rd order — 25 dB 5th order — 35 dB
Carrier Suppression	: SSB: —40 dB
Unwanted Sideband	: —50 dB
Frequency Response	: AM and SSB: 350 ~ 2500 Hertz
Output Impedance	: 50 ohm, unbalanced
Automatic Level Control (ALC)	: Adjustable, holds P.E.P. to 1dB increase w/10dB increase in audio input
SSB Filter	: 9.785 MHz, crystal lattice type 6 dB @ 4.0 KHz 50 dB @ 5.5 KHz
Output Indicator	: Backlite front panel meter

RECEIVER

Sensitivity	: SSB: 0.25 μ V for 10dB S+N/N
	AM: 0.5 μ V for 10dB S+N/N
Selectivity	: SSB: 6 dB @ \pm 2 KHz, 50 dB @ 5.5 KHz AM: 6 dB @ \pm 2 KHz, 50 dB @ 5.5 KHz

Image Rejection	: 50 dB
IF Frequency	: 9.785 MHz
Automatic Gain Control (AGC)	: Less than 10 dB increase in audio output for inputs of 1 to 500,000 μ V
Squelch	: Adjustable, Threshold less than 1 μ V
Noise Limiter	: Series gate type
Noise Blanker	: Deluxe noise blanker installed
Clarifier Range	: \pm 700 Hertz Minimum
Audio Output Power	: 4.0 watts with 10% T.H.D. into a 4 ohm load
Hum and Noise	: -40 dB
Built-in Speaker	: 3-1/2" (92 mm)
External Speaker (not supplied)	: 4 or 8 ohm, Disables internal speaker when connected.

PA SYSTEM

Power Output	: 4 watts into external speaker
External Speaker for PA	: 4 or 8 ohm, When PA/CB switch is in PA, the PA speaker also monitors the normal CB receiver

SERVICE MAINTENANCE

Should your LCMS-4 fail to perform as stated in this manual, it is recommended that SBE be contacted in writing at the following address:

SBE, INC.
220 Airport Boulevard
Watsonville, California 95076

SBE will either authorize return of the unit to the factory or refer you to an authorized SBE repair agency in your area. Do not ship equipment without prior written authorization from SBE. Your letter to SBE must include the following particulars.

1. Model number and serial number of equipment.
2. Date of purchase of equipment.
3. Nature of trouble.
4. Cause of trouble if known.

5. Name of distributor from whom the equipment should be returned.
 6. Your return address.
 7. Method of shipment by which the equipment should be returned.
 8. Should your unit require warranty service, proof of purchase will be necessary.
- In addition, include any information that you feel will be helpful in locating or correcting the problem.

PARTS ORDERING INFORMATION

When ordering replacement parts, you should direct your order to SBE's parts facility at:

220 Airport Blvd.
Watsonville, California 95076

Please furnish the following information:

1. Quantity required.
2. SBE part number and description.
3. Item or symbol number obtained from parts list, schematic, or component location drawing.
4. SBE model number and serial number.

Unless specified, SBE will determine the best method of shipment for the parts involved. If payment does not accompany the order, parts will be sent C.O.D.

LIMITED WARRANTY

SBE, Inc., warrants equipment manufactured by it to be free from defects in material or workmanship and agrees to repair or, at the option of manufacturer, to replace such equipment which under normal use and service, develops defects arising from the fault of the manufacturer (and existing at the date of original purchase). Equipment must be returned to the manufacturer or to one of the Certified Service Stations, transportation prepaid, at the address set forth below, within one year from the date of original purchase. Unless the warranty card has been filled in and returned within ten days of original purchase, this warranty shall be void.

This warranty does not apply to equipment which (1) has been repaired or altered by anyone in any way so as, in our judgment, to injure its stability or reliability, (2) has been subject to misuse, negligence, or accident, (3) has had the serial number altered, defaced or removed, or (4) has been connected, installed, adjusted other than in accordance with our written instructions.

The foregoing is in lieu of any other express warranty. ANY IMPLIED OR STATUTORY WARRANTIES INCLUDING ANY WARRANTY OF MERCHANTABILITY, APPLICABLE TO EQUIPMENT MANUFACTURED BY SBE, INC. SHALL EXIST FOR THE LESSER OF ONE YEAR OR THE DURATION OF THE EXPRESS WARRANTY HEREIN. In no event shall SBE, Inc. be liable for incidental or consequential damages.

Some states do not allow either limitations on how long an implied warranty lasts or the exclusion or limitation of incidental or consequential damages, so the above limitations and exclusions may not apply to you.

The warranty gives you specific legal rights and you may also have other rights which vary from state to state.

SBE, Inc., neither assumes nor authorizes any person to assume for it any other obligation or liability in connection with this equipment.

SBE, INC.
220 Airport Boulevard
Watsonville, California 95076
(408) 728-2071

We recommend that you record the following information at the time you purchase your LGM5-4. If your unit becomes damaged or lost, this information may then be supplied to your insurance company and/or the local police department.

1. Model Number _____
2. Serial Number* _____
3. Date Purchased _____
4. Dealer's Name _____
5. City _____
6. State _____

* Permanent number on case of radio.

MEMO

1	21	12	13	16
2	16	22	12	13
3	15	23	12	13
4	14	24	12	13
5	14	25	12	13
6	14	26	12	13
7	14	27	12	13
8	13	28	11	16
9	13	29	11	16
10	13	30	11	15
11	13	31	11	15
12	13	32	11	14
13	13	33	11	14
14	12	34	11	14
15	12	35	11	14
16	12	36	11	13
17	12	37	11	13
18	12	38	11	13
19	12	39	11	13
20	12	40	11	13

CIRCUIT DIAGRAM

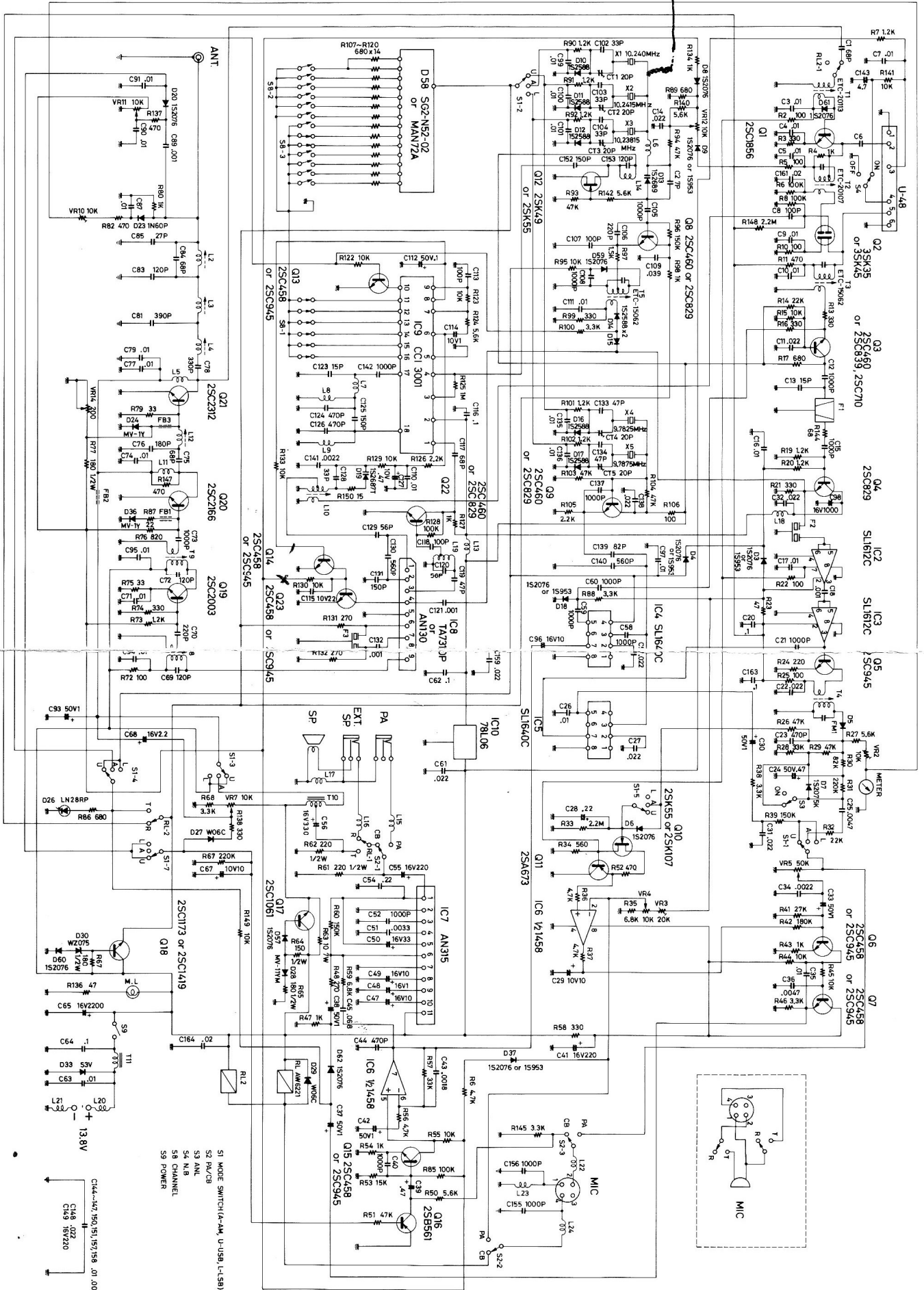

SI MODE SWITCH(4-4M U-58) L-(58)
 S2 PA/GB
 S3 ANL
 S4 N.B
 S5 CHANNEL
 S9 POWER

C144-147 150,151,157,158 .01 .001
 C148 .022
 C149 15V220

13.8V

