

This Information Is Provided By
CBTricks.com

Realistic TRC-450 Service Manual

Liability of damages to any equipment is the sole responsibility of the user! Downloading, viewing, or using any information provided on these pages automatically accepts the user to the terms of this agreement!

Modifications are provided for information purposes only!

Supporters of CBTricks.com paid for the hosting so you would have this file.

CBTricks.com is a non-commercial personal website was created to help promote the exchange of service, modification, technically oriented information, and historical information aimed at the Citizens Band, GMRS (CB "A" Band), MURS, Amateur Radios and RF Amps.

CBTricks.com is not sponsored by or connected to any Retailer, Radio, Antenna Manufacturer or Amp Manufacturer, or affiliated with any site links shown in the links database. The use of product or company names on my web site is not endorsement of that product or company.

The site is supported with donations from users, friends and selling of the Site Supporters DVD's to cover some of the costs of having this website on the Internet instead of relying on banner ads, pop-up ads, commercial links, etc. Thus I do not accept advertising banners or pop-up/pop-under advertising or other marketing/sales links or gimmicks on my website.

ALL the money from donations is used for CBTricks.com I didn't do all the work to make money (I have a day job). This work was not done for someone else to make money also, for example the ebay CD sellers.

All Trademarks, Logos, and Brand Names are the property of their respective owners.

This information is not provided by, or affiliated in any way with any radio or antenna Manufacturers.

Thank you for any support you can give.

For information on how to Support CBTricks.com

<http://www.cbtricks.com/support/>

REALISTIC[®]

Service Manual

21-1564

TRC-450 CB TRANSCEIVER Catalog Number: 21-1564



CUSTOM MANUFACTURED FOR RADIO SHACK  A DIVISION OF TANDY CORPORATION

TABLE OF CONTENTS

1. SPECIFICATIONS	3 ~ 5
2. DISASSEMBLY INSTRUCTIONS	6
3. BLOCK DIAGRAM	7
4. CIRCUIT DESCRIPTION	8 ~ 9
FREQUENCY CHART	10
5. ABBREVIATED CIRCUIT DESCRIPTION OF RECEIVER	11
6. ABBREVIATED DESCRIPTION OF TRANSMITTER CIRCUIT	12
7. ALIGNMENT INSTRUCTIONS	13 ~ 16
8. TROUBLESHOOTING HINTS	17 ~ 18
9. VOLTAGE CHART	19 ~ 20
10. IC INTERNAL DIAGRAMS	21
11. TRANSISTOR, DIODE, LED, & COMPOUND PARTS LEAD IDENTIFICATION	22
12. CHANNEL SWITCH P.C. BOARD	23
13. MIC P.C. BOARD	23
14. SLIDE SWITCH P.C. BOARD	23
15. LED P.C. BOARD	23
16. MAIN P.C. BOARD (TOP VIEW)	24
17. MAIN P.C. BOARD (BOTTOM VIEW)	25
18. ADDITIONAL PARTS ON THE BOTTOM	26
19. WIRING DIAGRAM	27 ~ 28
20. ELECTRICAL PARTS LIST	29 ~ 41
21. MECHANICAL PARTS LIST	42
 SCHEMATIC DIAGRAM/EXPLODED VIEW	 SEPARATE SHEET

1. SPECIFICATIONS

GENERAL:

Channels	: 40 Channels for AM, Upper Side Band and Lower Side Band, utilizing Digital Circuitry
Frequency Range	: 26.965 MHz to 27.405 MHz
Frequency Control	: Digital (Phase Lock Loop) Synthesizer
Frequency Accuracy	: ± 100 Hz
Operating Temperature Range	: -20°C to $+50^{\circ}\text{C}$
Power Requirements	: 13.8V DC (12-16 volts DC, negative or positive ground)
Antenna	: 52 ohm (Coaxial connector)
Microphone	: 600 ohm Dynamic Type
Speaker	: 8 ohm, 3 Watt
Size (H x W x D)	: 2-1/4" x 7-1/4" x 9-1/4" (5.8 x 18.5 x 23.5 cm)
Weight	: 4.4 lbs. (approx.) (2.0 kg)
Accessories	: DC Cord with in-line Fuse, Microphone and Microphone Bracket and Mounting Bracket

MEASUREMENT CONDITION:

Power Source	: 13.8V DC
Antenna Impedance	: 50 ohm
Test Temperature	: 25°C
AM Modulation Frequency	: 1 kHz
SSB Modulation Frequency, Transmit	: Two tone: 500 Hz and 2400 Hz Single tone: 1 kHz
Mean Signal Input Level	: $1000\ \mu\text{V}$
Reference Audio Output Power	: 0.5 W
Reference AM Modulation Percentage	: 1 kHz, 30%
Audio Frequency, SSB Receive	: 1 kHz
Audio Output Load	: 8 ohms resistive
Measuring Channel	: 19

RECEIVER:(ANL & Noise Blanker Switch OFF)

		UNIT	NOMINAL	LIMIT	
Max. Sensitivity	: AM	μV	0.5	1	
	: SSB	μV	0.25	0.5	
Sensitivity for 10 dB S/N	: AM	μV	0.5	1	
	: SSB	μV	0.25	0.5	
AGC Figure-of-Merit 100 mV for 10 dB Change in Audio Output	: AM	dB	90	80	
	: SSB	dB	90	80	
Overload AGC Characteristics from 100 mV to 100 mV	: AM	dB	± 3	± 5	
	: SSB	dB	± 3	± 5	
Overall Audio Fidelity at -6 dB Down Upper Frequency	: AM	Hz	2100	1750 ~ 2500	
	: SSB	Hz	3500	2500 ~ 5000	
Lower Frequency	: AM	Hz	450	250 ~ 650	
	: SSB	Hz	450	250 ~ 650	
Cross Modulation, RS Standard	: AM	dB	60	50	
Adjacent Channel Selectivity (10 kHz)	: AM	dB	70	60	
	: SSB	dB	70	60	
Maximum Audio Output Power	: AM	W	4	3	
	: SSB	W	4	3	
Audio Output Power at 10% THD	: AM	W	3	2.5	
	: SSB	W	3	2.5	
THD at 500 mW Audio Output	AM: 1 mV Input, 30% modulation	: AM	%	3	6
	80% modulation	: AM	%	5	8
	SSB: 1 mV Input, 1 kHz, Single-tone	: SSB	%	3	6
RF Gain Control Range at Max. Sensitivity Level	: AM	dB	40	30 ~ 60	
	: SSB	dB	40	30 ~ 60	
S/N Ratio at 1 mV Input	: AM	dB	40	34	
	: SSB	dB	40	34	
Squelch Sensitivity at Threshold	: AM	μV	0.5	2	
	: SSB	μV	0.5	2	
S Meter Sensitivity at "S-9" (No Modulation AM)	: AM	μV	100	25 ~ 400	
	: SSB	μV	100	25 ~ 400	
Image Rejection Ratio, $f_o+(2 \times 7.8 \text{ MHz})$: AM	dB	76	66	
	: SSB	dB	76	66	
1/2 IF Rejection Ratio, $f_o+7.8 \text{ MHz}/2$: AM	dB	85	75	
	: SSB	dB	85	75	
IF Rejection Ratio, 7.8 MHz	: AM	dB	85	75	
	: SSB	dB	85	75	
Oscillator Drop-out Voltage	: AM	V	9	11	
	: SSB	V	9	11	
Clarifier Range	: AM	kHz	± 1.25	$\pm 0.6 \sim \pm 2.5$	
	: SSB	kHz	± 1.25	$\pm 0.6 \sim \pm 2.5$	
Spurious Rejection Ratio	In band	: AM	dB	65	56
		: SSB	dB	65	56
	Out of Band	: AM	dB	60	50
		: SSB	dB	60	50

		UNIT	NOMINAL	LIMIT
Battery Drain at No Signal	: AM	mA	250	500
	: SSB	mA	250	500
Battery Drain at Maximum Output Power	: AM	mA	1000	1500
	: SSB	mA	1000	1500
PUBLIC ADDRESS:				
Microphone Sensitivity for 3W Output Power at 1 kHz		mV	1.5	3
Maximum Output Power		W	4	3
TRANSMITTER:				
Frequency Tolerance at 25° C (5 Minutes after switch on)	: AM	%	±0.0005	±0.003
	: SSB	%	±0.0005	±0.003
Carrier Power at No Modulation	: AM	W	4 max.	3.5 – 4.4
PEP Power, Two Tone	: SSB	W PEP	12	10 – 13.2
Modulation Distortion at 1 kHz, 80% Modulation	: AM	%	3	8
Spurious Harmonic Emission	: AM	dB	-65	-60
	: SSB	dB	-65	-60
Carrier Suppression	: SSB	dB	-55	-40
Unwanted Sideband Suppression at 2.5 kHz	: SSB	dB	-55	-40
Modulation Frequency Response at -6 dB Down (1 kHz, 0 dB reference)				
Lower Frequency	: AM	Hz	450	250 ~ 650
	: SSB	Hz	450	250 ~ 650
Upper Frequency	: AM	Hz	2500	2000 ~ 4000
	: SSB	Hz	3500	2000 ~ 5000
Carrier Power Uniformity, Ch-to-Ch at No Modulation	: AM	W	0.3	0.4
Mic Input Level Uniformity, Ch-to-Ch for 4 watts Output 2.5 kHz Single Tone, SSB		dB	2	3
Mic Input Level Uniformity, LSB to USB for 4 watts Output, 1.5 kHz Single Tone		dB	1	3
Microphone Sensitivity				
AM: For 50% Modulation	: AM	mV	0.4	1.0
SSB: For 4 watts PEP	: SSB	mV	0.4	1.0
AMC Range				
AM: 50 ~ 100% Modulation	: AM	dB	50	40
SSB: 10 ~ 13.2 watts PEP	: SSB	dB	50	40
Battery Drain at No Modulation	: AM	mA	2200	3000
	: SSB	mA	500	1000
Battery Drain				
AM: 80% Modulation	: AM	mA	2200	3000
SSB: 10 watts PEP, Two tone	: SSB	mA	2000	3000

Note: Nominal Specs represent the design specs; all units should be able to approximate these, some will exceed and some may drop slightly below these specs.

Limit Specs represent the absolute worst condition which still might be considered acceptable, in no case should a unit perform to less than within any Limit Spec.

2. DISASSEMBLY INSTRUCTIONS

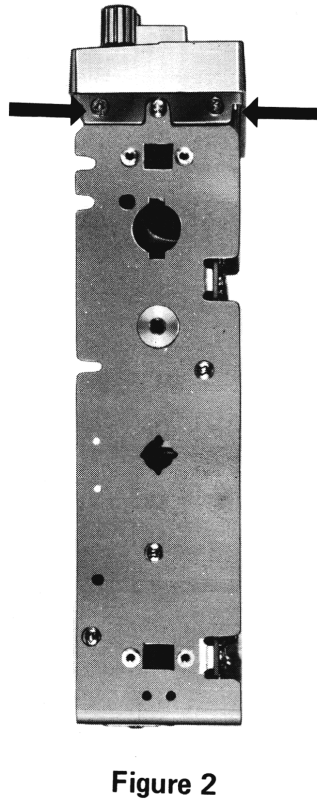
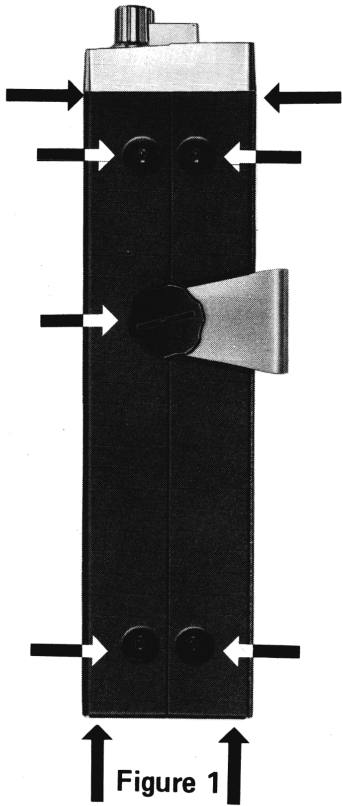

1. To remove Top & Bottom Cover: (Figure 1)
Remove 5 screws from each side and two screws from rear. Slide the top toward the rear of the chassis and remove.
2. To remove Front Panel: (Figure 2)
Remove 2 screws from each side.

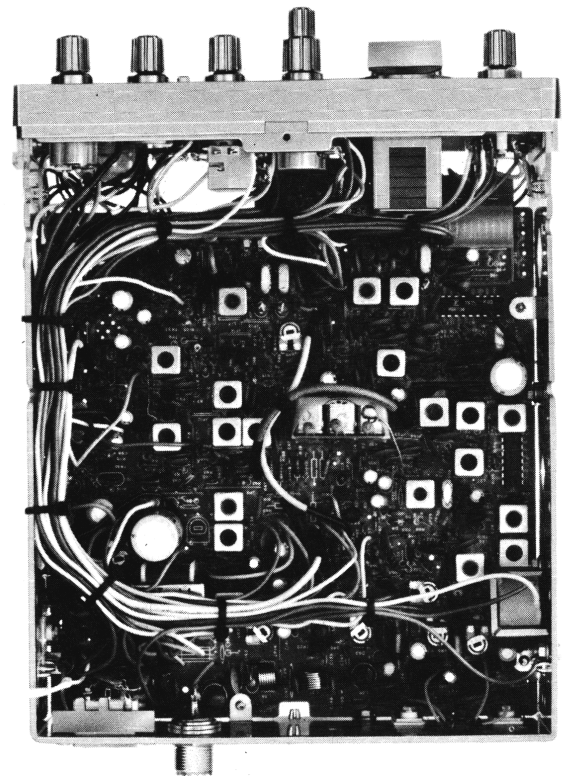
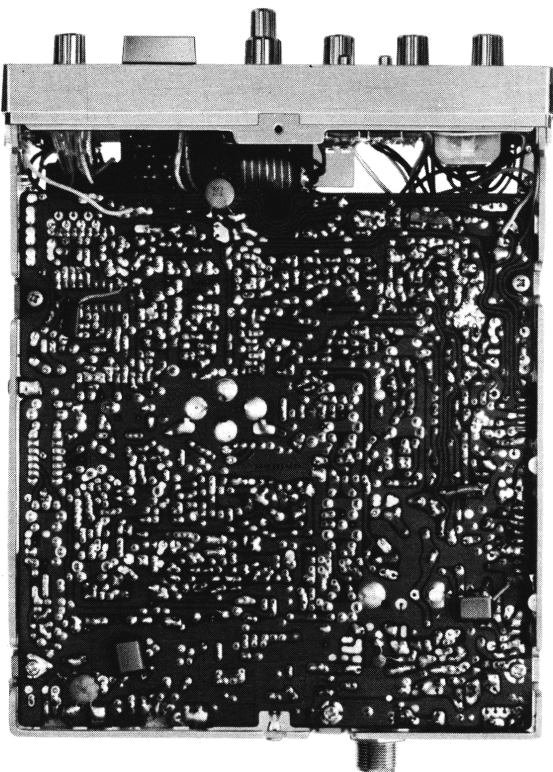

3. BLOCK DIAGRAM

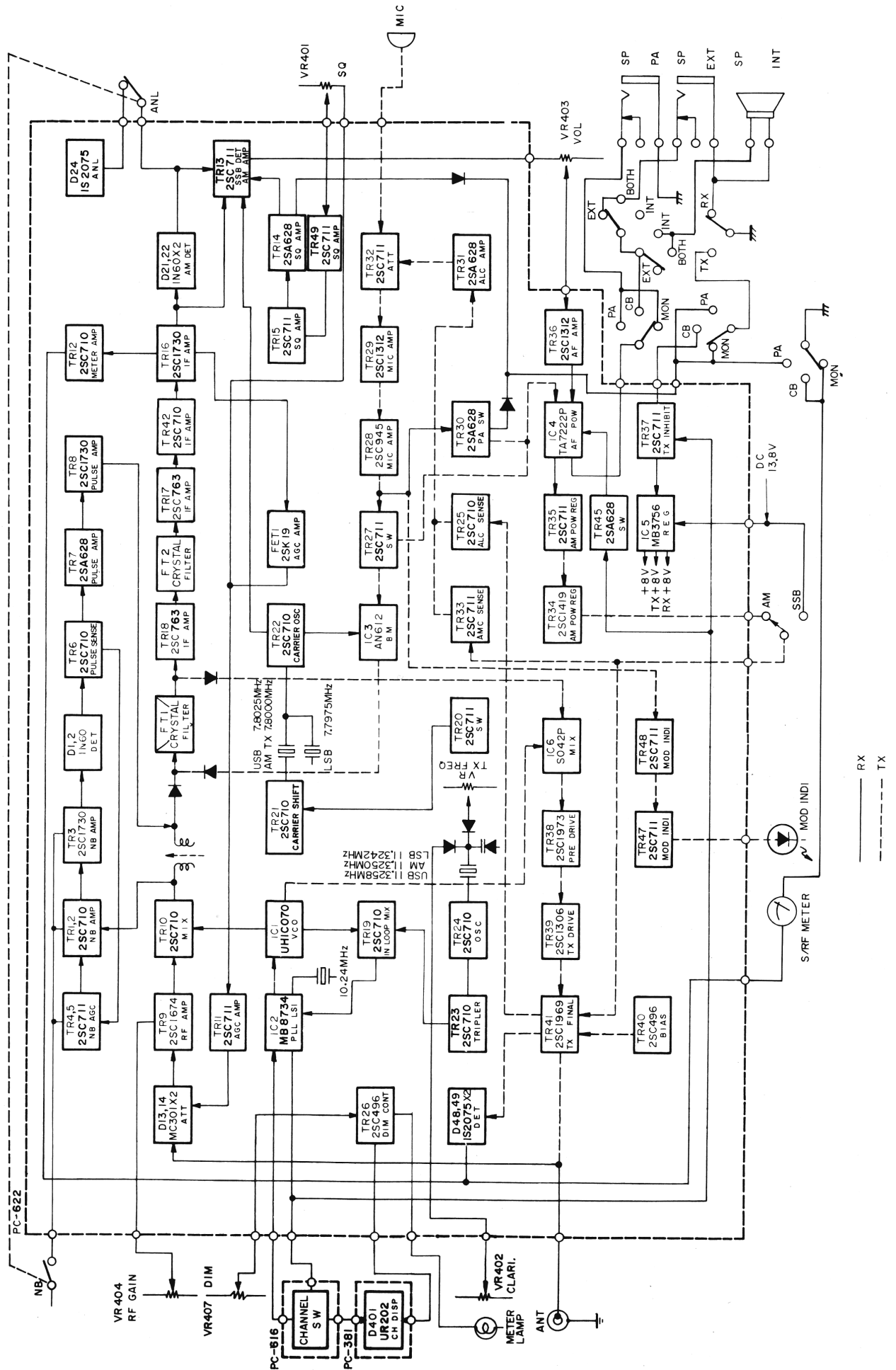

4. CIRCUIT DESCRIPTION

1. PLL

The PLL circuit (Phase Locked Loop) used in TRC-450 consists of 6 major components: VCO (Voltage Controlled Oscillator), 1/N Divider, Reference Oscillator, 1/1024 Divider, Phase Detector and Low Pass Filter.

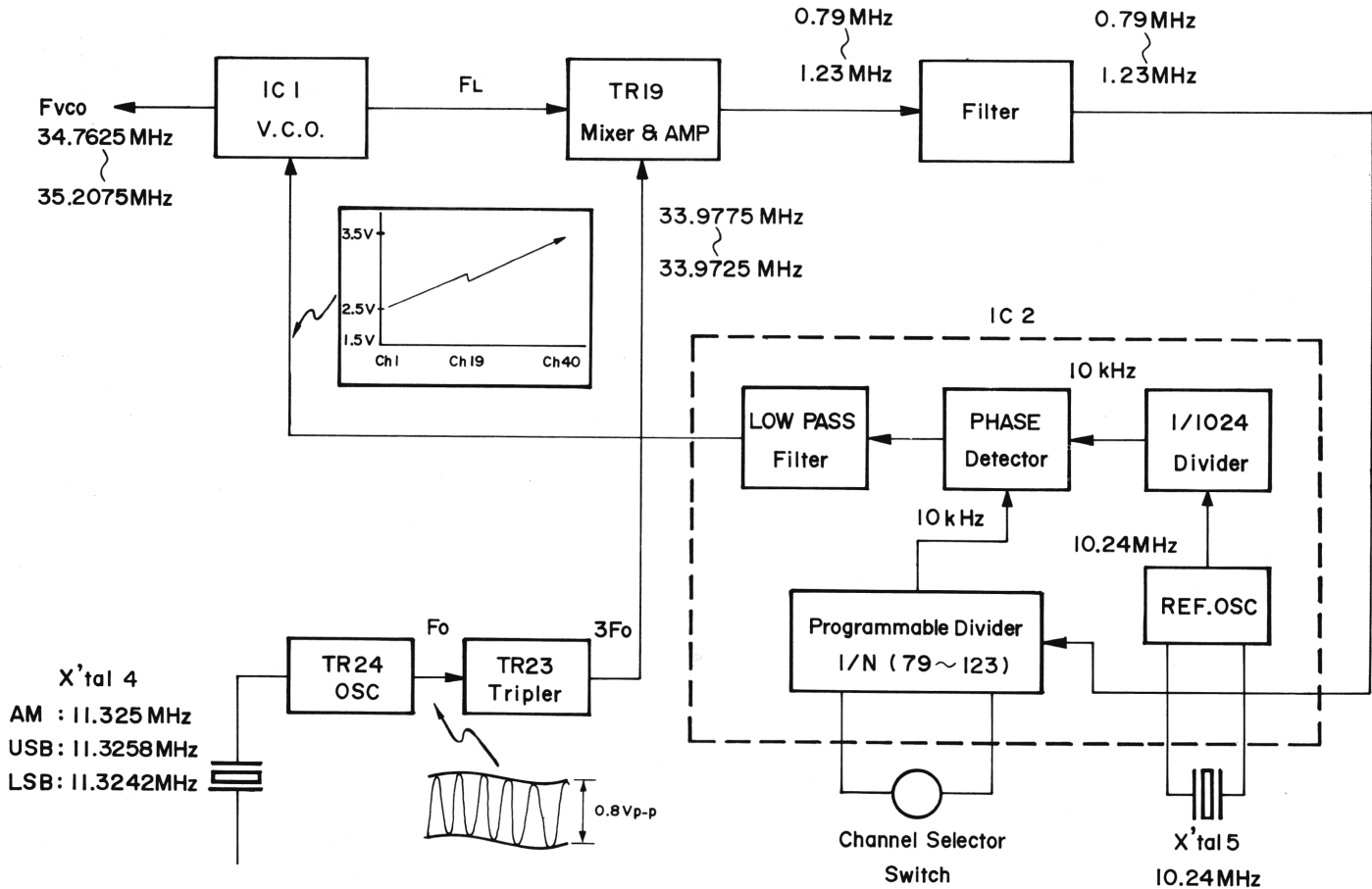

The VCO is an Oscillator which controls oscillation frequency in accordance with input voltage changes. 1/N Divider is a Programmable Divider; the "N" is varied by Channel Selector Switch. A portion of the VCO output is mixed with a signal from TR24 by TR19, "In-Loop mixer". It is used to shift the VCO frequency. TR24, "In-Loop Local Oscillator", generates 11 MHz frequency (AM: 11.3250 MHz, USB: 11.3258 MHz and LSB: 11.3242 MHz). This 11 MHz signal is fed to TR19, Mixer, passing through the TR23, Tripler. VCO frequency is down-mixed with a signal from TR23, providing 0.79 MHz through 1.23 MHz (see frequency table). The signal is fed to the 1/N Divider through the Filter. The Filter eliminates harmonics. 1/N Divider produces the 10 kHz frequency and it is fed to the Phase Detector.

On the other hand, the 10.24 MHz frequency generated by X5, is changed to 10 kHz by 1/1024 Divider and is fed to another input of the Phase Detector. Thus the Phase Detector receives two signals (both 10 kHz). It compares the phase

difference of the two and generates an error voltage which acts on the VCO to bring the two frequencies exactly in-phase. When this condition occurs, the PLL circuit is "Locked". A Low Pass Filter is used to change the AC signal to DC.

Then the VCO output is down-mixed with Local Oscillator frequency (X2, X3 and TR22) and the resulting 27 MHz frequencies are transmitted.

By varying the constant N, the output frequency from the VCO can be varied in 10 kHz steps. The constant N is controlled by the Channel Selector Switch. A frequency shift of 2.5 kHz (required for AM, USB and LSB) is obtained by switching Diodes D32 (LSB), D33 (USB) and D34 (AM).

2. LOCAL OSCILLATOR (CARRIER OSCILLATOR)

TR22 is a carrier oscillator which generates 7.8025 MHz, 7.7975 MHz or 7.8000 MHz.

In USB mode, X2 functions by D27 switching; so TR22 oscillates on 7.8025 MHz.

In LSB mode, X3 functions by D26 switching and TR22 oscillates on 7.7975 MHz.

In AM mode, when the unit is in transmitting, X2 functions by D28 switching and also TR21 is "on". L17 is used to vary the oscillation frequency of X2.

Therefore TR22 oscillates on 7.8000 MHz. When receiving an AM or in SSB modes, the TR20 is "on" and cuts off TR21.

The carrier output goes to the receiver circuit for demodulation of SSB signal or goes to transmitter circuit for modulation.

3. CHANNEL SELECTION PROGRAM

The Divide Ratio N, is determined by voltages supplied to the program input terminals, pins No. 11 through 16 of IC2. The function of the program input terminals is shown below;

Pin No. of IC2	16	15	14	13	12	11	*
Significant	2^0	2^1	2^2	2^3	2^4	2^5	2^6
constant	1	2	4	8	16	32	64

Note: *Always high level: Added internally in IC2.

The Divide Ratio N of the Programmable Divider is determined by the sum of the significant number(s) which are at "high" level. For example, on Channel 1, Pins 13, 14, 15 and 16 are "high" level (see frequency table). So the Divide Ratio N is determined as follows.

$$N = 1 + 2 + 4 + 8 + (64) = 79$$

In the same manner, the Divide Ratio N for Ch. 1 through 40 is determined as shown in the Frequency Chart.

For example, when the unit is transmitting on Channel 19, the frequencies will be as shown in following table:

	AM mode	USB mode	LSB mode
N	101	101	101
3 x F_o (MHz) (TR23)	33.9750	33.9775	33.9725
N x 10 kHz (MHz) output of TR19	1.01	1.01	1.01
F_L VCO Frequency (MHz)	34.9850	34.9875	34.9825
F_I (MHz) Local Oscillator Frequency	7.8000	7.8025	7.7975
F_t Transmit Frequency (MHz)	27.185	27.185	27.185

FREQUENCY CHART

CH	ANTENNA OUTPUT FREQUENCY	N	1/N INPUT FREQUENCY	PIN NO. OF IC2						LOCAL OSC OUTPUT FREQUENCY		
				16	15	14	13	12	11	AM.RX	USB&AM.TX	LSB
1	26.965	79	0.79	1	1	1	1	0	0	34.765	34.7675	34.7625
2	26.975	80	0.80	0	0	0	0	1	0	34.775	34.7775	34.7725
3	26.985	81	0.81	1	0	0	0	1	0	34.785	34.7875	34.7825
4	27.005	83	0.83	1	1	0	0	1	0	34.805	34.8075	34.8025
5	27.015	84	0.84	0	0	1	0	1	0	34.815	34.8175	34.8125
6	27.025	85	0.85	1	0	1	0	1	0	34.825	34.8275	34.8225
7	27.035	86	0.86	0	1	1	0	1	0	34.835	34.8375	34.8325
8	27.055	88	0.88	0	0	0	1	1	0	34.855	34.8575	34.8525
9	27.065	89	0.89	1	0	0	1	1	0	34.865	34.8675	34.8625
10	27.075	90	0.90	0	1	0	1	1	0	34.875	34.8775	34.8725
11	27.085	91	0.91	1	1	0	1	1	0	34.885	34.8875	34.8825
12	27.105	93	0.93	1	0	1	1	1	0	34.905	34.9075	34.9025
13	27.115	94	0.94	0	1	1	1	1	0	34.915	34.9175	34.9125
14	27.125	95	0.95	1	1	1	1	1	0	34.925	34.9275	34.9225
15	27.135	96	0.96	0	0	0	0	0	1	34.935	34.9375	34.9325
16	27.155	98	0.98	0	1	0	0	0	1	34.955	34.9575	34.9525
17	27.165	99	0.99	1	1	0	0	0	1	34.965	34.9675	34.9625
18	27.175	100	1.00	0	0	1	0	0	1	34.975	34.9775	45.9725
19	27.185	101	1.01	1	0	1	0	0	1	34.985	34.9875	34.9825
20	27.205	103	1.03	1	1	1	0	0	1	35.005	35.0075	35.0025
21	27.215	104	1.04	0	0	0	1	0	1	35.015	35.0175	35.0125
22	27.225	105	1.05	1	0	0	1	0	1	35.025	35.0275	35.0225
23	27.255	108	1.08	0	0	1	1	0	1	35.055	35.0575	35.0525
24	27.235	106	1.06	0	1	0	1	0	1	35.035	35.0375	35.0325
25	27.245	107	1.07	1	1	0	1	0	1	35.045	35.0475	35.0425
26	27.265	109	1.09	1	0	1	1	0	1	35.065	35.0675	35.0625
27	27.275	110	1.10	0	1	1	1	0	1	35.075	35.0775	35.0725
28	27.285	111	1.11	1	1	1	1	0	1	35.085	35.0875	35.0825
29	27.295	112	1.12	0	0	0	0	1	1	35.095	35.0975	35.0925
30	27.305	113	1.13	1	0	0	0	1	1	35.105	35.1075	35.1025
31	27.315	114	1.14	0	1	0	0	1	1	35.115	35.1175	35.1125
32	27.325	115	1.15	1	1	0	0	1	1	35.125	35.1275	35.1225
33	27.335	116	1.16	0	0	1	0	1	1	35.135	35.1375	35.1325
34	27.345	117	1.17	1	0	1	0	1	1	35.145	35.1475	35.1425
35	27.355	118	1.18	0	1	1	0	1	1	35.155	35.1575	35.1525
36	27.365	119	1.19	1	1	1	0	1	1	35.165	35.1675	35.1625
37	27.375	120	1.20	0	0	0	1	1	1	35.175	35.1775	35.1725
38	27.385	121	1.21	1	0	0	1	1	1	35.185	35.1875	35.1825
39	27.395	122	1.22	0	1	0	1	1	1	35.195	35.1975	35.1925
40	27.405	123	1.23	1	1	0	1	1	1	35.205	35.2075	35.2025

0 = Low level (0 – 1.0 volt)

1 = High level (3.5 – 6 volts)

5. ABBREVIATED CIRCUIT DESCRIPTION OF RECEIVER

(Refer to schematic and block diagram)

1. RF Stage

A signal from the antenna is fed to RF Amplifier, TR9. The signal is processed to Mixer, TR10. The signal is mixed with a signal from the VCO (approx. 35 MHz) by TR10 and a 7.8 MHz signal (IF frequency) is produced.

2. IF Stage

The 7.8 MHz signal is amplified by TR18, 17, 42 and TR16.

In the AM mode, the signal is detected by D21 and 22, and passed on to TR13, AF amplifier.

In the SSB modes, the signal is fed to TR13. TR13 operates as a Demodulator in SSB modes. To demodulate the SSB signal, the 7.8 MHz signal is needed. The signal then goes to IC4, AF Power Amp.

3. AF Stage

The signal from TR13 is amplified by TR36, AF Pre-Amp, and IC4, AF Power amplifier. And sound is heard from the Speaker.

4. AGC

FET1 is an AGC amplifier. A portion of the IF signal is amplified by FET1 and processed to TR18, which adjusts the gain of TR18. The signal also is applied to TR11, which controls an RF attenuator consisting of D13 and D14.

5. Squelch

A portion of FET1's output goes to the squelch circuit. The squelch circuit consists of TR14 and TR15; the output of TR14 is used to cut off TR13.

6. Clarifier

In the Receive mode, the output of X4 is varied in frequency by D37, Varactor Diode, and Clarifier Control, VR402.

In the Transmit mode, the voltage to D37 is fixed by VR3, so the frequency is stable.

7. ANL

The ANL circuit consists of D24 and relating circuits. The ANL circuit is effective on AM mode only. ANL is a clipping circuit; the clipping level is automatically determined by the carrier voltage.

8. Noise Blanker

A signal, included noise signal components from the antenna, is converted to the 7.8 MHz IF frequency by TR10 and fed to TR1. The 7.8 MHz signal, including noise, is amplified by TR1, 2 and TR3 and then detected by D1 and D2. The detected signal is fed to TR6, Sensor, which discriminates only a pulse-type noise from the signal. The pulse-type noise is amplified by TR7 and drives TR8 "on". Therefore, if noise exists, TR8 turns "on" and noise is reduced.

TR4 and TR5 provide AGC, so that the noise blanker output is reduced or eliminated in the presence of a strong signal.

9. Transmit/Receive Control

TX/RX is controlled by pin 1, 3 and pin 5 of MIC jack. When pin 5 is shorted to pin 1, the unit is in Receive. If pin 3 is shorted to pin 1, the unit is in Transmit.

IC5 is a Voltage Regulator. 13.8-volt DC power is applied to pin 2 of the IC. If pin 5 of the IC is high, DC voltage appears on pins 1 and 6. Pin 1 goes to + B of PLL circuit and pin 6 goes to + B of Receiver circuit. If pin 5 becomes low, DC voltage appears on pins 1 and 8. Pin 8 goes to + B of Transmitter circuit.

6. ABBREVIATED DESCRIPTION OF TRANSMITTER CIRCUIT

1. AM

An AF signal from the Mic is fed to TR29. This signal is amplified by TR29 and TR28, Mic Amp, and is fed to IC4, AF Amp, passing TR27, AM Switching transistor. The signal amplified by IC4 is applied to TR39 and TR41 for modulation.

For the RF portion, two signals are mixed by IC6, Mixer, with a 27 MHz signal being produced. [One of these signals is 7.8 MHz which is generated by TR22 and other signal is the VCO output (approx. 35 MHz).] The 27 MHz signal is amplified by TR38, Pre-Driver. The signal is amplified and modulated by TR39 and 41 and is delivered to the Antenna. A portion of the signal is detected by D48 and D49 and Drives the RF PWR meter.

2. SSB

The audio signal from Mic is amplified by TR29 and TR28; it then is applied to IC3, Balanced Modulator. The carrier signal (7.8025 for USB or 7.7975 MHz for LSB) is applied to the other input of IC3. IC3 produces a carrier-suppressed DSB signal. The DSB signal is converted into SSB by FT1, Filter. In the USB mode, carrier — audio signal is produced. And in the LSB mode, carrier + audio signal is produced.

Example: In the USB mode, if 1 kHz audio signal modulates the carrier signal, two signals are produced as shown below:

$$7.8025 \text{ MHz} + 1 \text{ kHz} = 7.8035 \text{ MHz}$$

$$7.8025 \text{ MHz} - 1 \text{ kHz} = 7.8015 \text{ MHz}$$

But the 7.8035 MHz is suppressed by FT1, because the bandwidth of the FT1 is within ± 2.5 kHz of 7.8000 MHz.

The SSB signal is converted to 27 MHz by IC6. IC6 is a Mixer, and mixes the SSB signal with the VCO output of PLL.

The resulting SSB signal is amplified by TR38, 39 and TR41 and is delivered to the Antenna.

AMC CIRCUIT

TR33 is a detector for AMC and the Input Attenuator consists of R99 and TR32. In an over-modulation condition, TR33 turns on and the detected current flows into R124 through R100, R101 and TR33. This current drives TR31, and TR31 drives TR32. As the C-E impedance of TR32 lowers, the input signal is lowered. The AMC circuit is not effective in SSB modes.

ALC CIRCUIT

TR25 is an ALC detector which detects peak RF power. If the power level exceeds a level that is selected by VR7, TR25 turns on and drives TR31. TR31 drives TR32 to decrease the input audio signal. ALC is effective only on SSB modes. In AM mode, the emitter voltage of TR25 is pulled up to + B, and thus the ALC circuit is inoperative.

UNLOCK DETECTOR

TR37 is provided to shut off the Transmit output if the PLL is unlocked. TR45 is provided to turn off IC4.

In an unlocked condition, pin 6 of IC2 goes low. This turns on TR45 which shuts off IC4. At the same time TR37 turns off.

PUBLIC ADDRESS

A signal from the Mic is amplified by TR29 and TR28, is passed on through TR30, PA Switching Transistor and is applied to TR36. TR36 amplifies the signal, which then is applied to IC4 where it is further amplified before output to the PA speaker.

7. ALIGNMENT INSTRUCTIONS

CHASSIS LAYOUT, ALIGNMENT POINTS

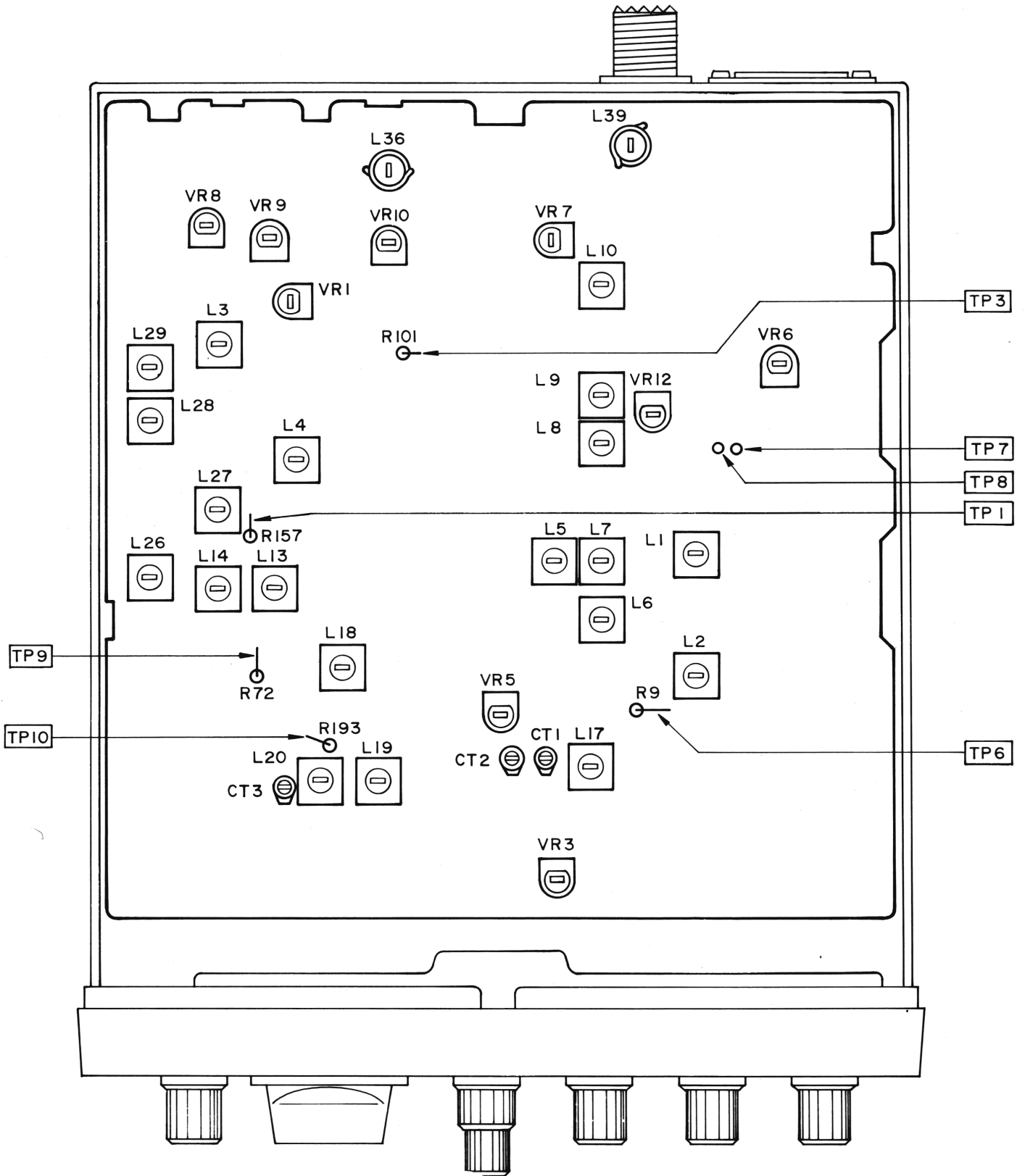

ALIGNMENT OF PLL AND CARRIER OSCILLATOR

1. Test Equipment required:

- a. Oscilloscope (DC – 50 MHz)
- b. Frequency Counter (0 – 30 MHz)
- c. DC Power Supply
- d. 50 ohm Load

2. Alignment Procedure: (See page 13)

Connect test equipment as shown below.

STEP	PRESET TO	CONNECTION	ADJUSTMENT
1	CH: 40, USB, RX, Clarifier in center	TP-9 (lead of R-72)	Adjust L-13 for 3.5V DC reading on Oscilloscope. (Oscilloscope in DC mode)
2	Same as step 1. CH: 1.	TP-9	Check that the voltage is more than 2V DC on Oscilloscope.
3	Same as step 1. CH: 19.	TP-10 (lead of R-193)	Adjust L-18 for maximum reading on Oscilloscope. (Oscilloscope in AC mode).
4	Same as step 3.	TP-1 (lead of R-157)	Adjust L-14 for maximum reading on Oscilloscope.
5	Same as step 3.	TP-1	Adjust CT-3 for 34.987500 MHz \pm 20 Hz.
6	Same as step 1. CH: 19, AM.	TP-1	Adjust L-20 for 34.985000 MHz \pm 20 Hz.
7	Same as step 1. CH: 19, LSB.	TP-1	Adjust L-19 for 34.9825 MHz \pm 20 Hz.
8	Same as step 1. CH: 19, LSB, TX.	TP-1	Adjust VR-3 for 34.9825 MHz \pm 20 Hz.
9	Same as step 1. CH: 19, LSB	TP-3 (lead of R-101)	Adjust CT-2 for 7.797500 MHz $\begin{matrix} +0 \\ -5 \end{matrix}$ Hz.
10	Same as step 1. CH: 19, USB.	TP-3	Adjust CT-1 for 7.802500 MHz $\begin{matrix} +5 \\ -0 \end{matrix}$ Hz.
11	Same as step 1. CH: 19, TX.	TP-3	Adjust L-17 for 7.800000 MHz \pm 5 Hz.

PLL AND CARRIER OSCILLATOR TEST EQUIPMENT SETUP

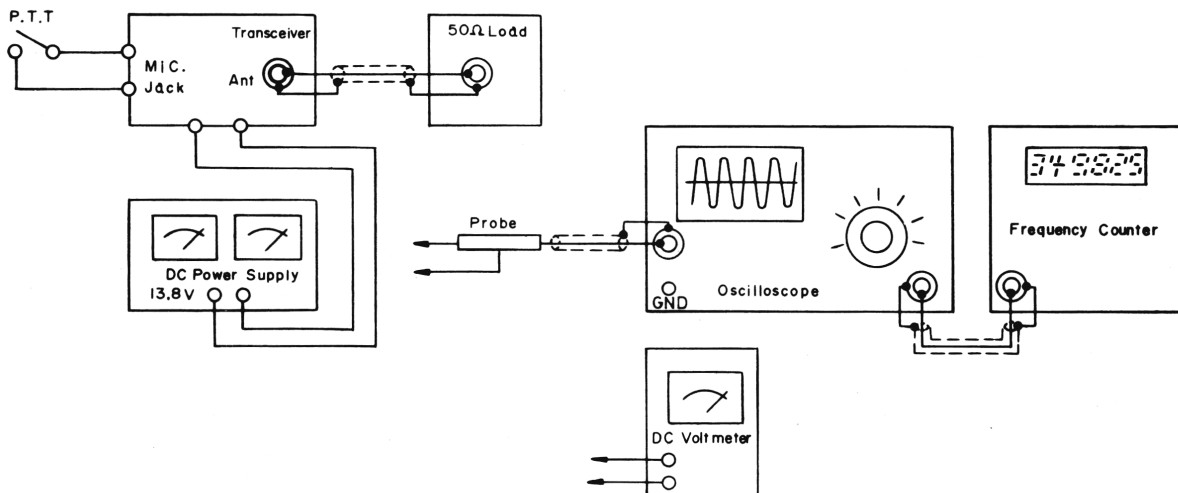

ALIGNMENT OF TRANSMITTER SECTION

1. Equipment Required:

- | | |
|--|--|
| a. AF Oscillator (two required) | f. Oscilloscope |
| b. AF VTVM (Full scale: 1V DC with RF probe) | g. RF VTVM |
| c. DC Ammeter | h. Monitor Receiver or Spectrum Analyzer |
| d. RF Power Meter | i. DC Power Supply (13.8 V/3 amp.) |
| e. 50 ohm load and Attenuator | |

2. Alignment Procedure: (See page 13)

Connect test equipment as shown below.

STEP	PRESET TO	ADJUSTMENT	REMARKS
1	CH:19, PA/CB:CB USB mode, TX S1 and S2: OFF	VR8	Break circuit at TP8, place DC mA meter in series. Adjust for 30mA ± 5 mA. If you cannot obtain 30 mA, set VR8 for max. current.
2	Same as step 1	VR9	Break circuit at TP7, place DC mA meter in series. Adjust for 60mA ± 5 mA. If you can not obtain 60mA, set VR9 for max. current.
After STEPs 1 and 2, restore circuit at TP8 and TP7.			
3	Same as step 1 OSC1: 500 Hz OSC2: 2400 Hz S1 and S2: ON	L26,27,28 and L29	Set VR7 to full CW rotation (ALC "off" condition). Keep AF ATT setting for approx. 20V reading on RF VTVM. Then adjust coils for max. reading. Repeat this adjustment several times, reducing the AF input level to the microphone circuit.
4	Same as step 3	L28 and L29	Set the core of L29 at the bottom. Adjust L28 for max. reading on RF VTVM. Then adjust L29 for max. reading. Check the power difference between CH1 and CH40. If it is over 1V on RF VTVM, readjust L29 to obtain within 1V.
5	Same as step 1 AM mode OSC1: 1 kHz S1: ON, S2:OFF	L36	Adjust level of OSC1 for 5mV reading on AF VTVM, then adjust L36 for maximum reading on RF VTVM.
6	Same as step 1 S1 and S2: OFF	VR5	Adjust for minimum carrier leakage for both USB and LSB on Spectrum Analyzer or Oscilloscope.
7	Same as step 3	VR7	Adjust OSC1 and OSC2 for 5mV reading on AF VTVM, then adjust VR7 for 24.5V reading on RF VTVM.
8	Same as step 1 AM mode S1 and S2: OFF	VR6	Adjust for 4.0W reading on RF Power meter
9	Same as step 8	VR10	Adjust for "4W" reading on the Transceiver's meter.
10	Same as step 8	L39	Adjust for minimum 2 nd harmonic (54 MHz) on Spectrum Analyzer or Monitor receiver.

TRANSMITTER TEST EQUIPMENT SETUP

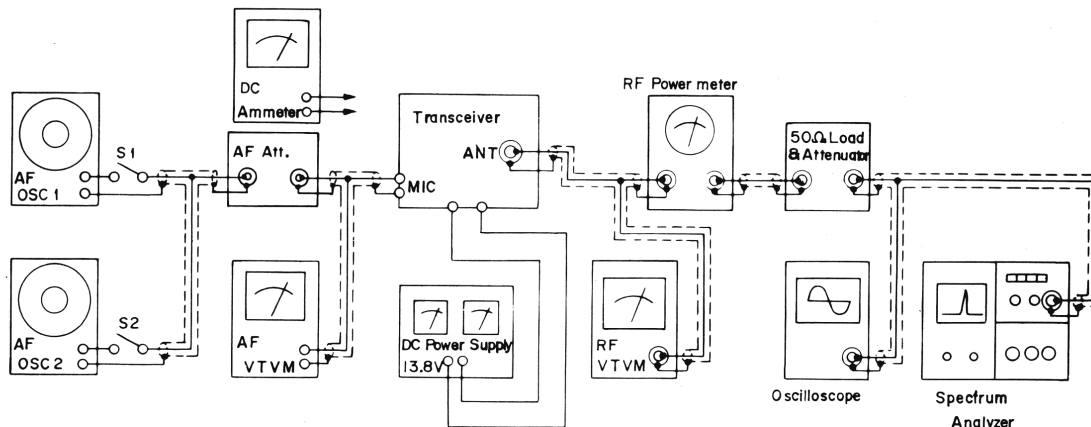

ALIGNMENT OF RECEIVER SECTION

1. Equipment Required

- RF Signal Generator (27 MHz Band, 50 ohm output impedance)
- AF VTVM
- Oscilloscope
- DC Power Supply
- 8 ohm Load

2. Procedure (See page 13)

Connect Test Equipment as shown below.

STEP	PRESET TO	ADJUSTMENT	PROCEDURE
1	Channel: 19 Clarifier: center Volume: fully CW. RF GAIN; fully CW. Squelch; fully CCW. NB/ANL: OFF EXT SP/BOTH/INT SP: EXT SP Mode: AM		Set the SG on channel 19, 27.185 MHz with 1 kHz, 30% modulation.
2	Same as step 1	L10,9,8,7,6,5,4 and 3.	Adjust the level of SG to obtain 2V reading on AF VTVM. Then adjust coils for maximum reading on AF VTVM. Repeat this step reducing the SG output.
3	Same as step 1	L8 and 9.	Set the core of L8 at the bottom. Adjust L9 for max. reading on AF VTVM. Then adjust L8 for max. reading. Check the sensitivity difference between CH1 and 40. If it is over 1 dB, re-adjust L8 to obtain within 1 dB.
4	Same as step 1 except Squelch is fully CW.	VR12	Set the level of SG to 1000 μ V. Then adjust VR2 so that the AF signal will just appear on Oscilloscope.
5	Same as step 1	VR1	Set the level of SG to 100 μ V. Then adjust for "S-9" reading on Transceiver's meter.
6	Same as step 1 except NB/ANL switch is ON.	L1 and 2.	Connect the Oscilloscope to TP6. Adjust the level of SG to approx. 1.6 μ V. Then adjust for max. DC reading.

RECEIVER TEST EQUIPMENT SETUP

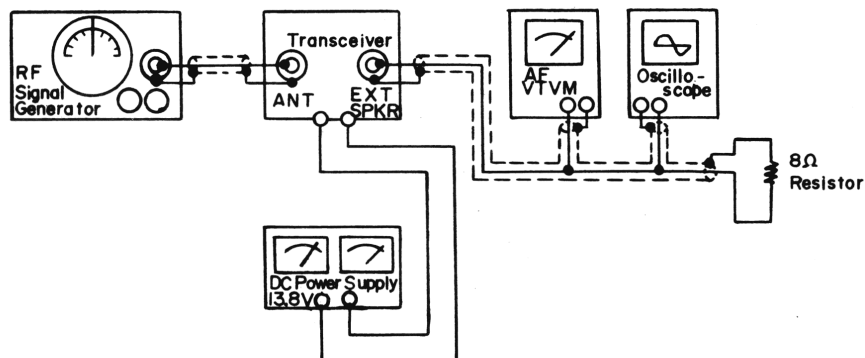

8. TROUBLESHOOTING HINTS

UNIT WILL NOT TURN ON

1. Broken DC Power cable.
2. Fuse blown. Be sure you check for the cause.
3. Defective power switch.
4. Defective wires or poor soldering in power supply circuit.

NO RECEIVE SOUND

1. Defective RF circuit in receiver.
2. Defective Noise Blanker.
3. Defective AGC circuit.
4. Defective PLL circuit.
5. Defective antenna connector.

NO NOISE

1. Broken or bad contact in microphone connector and/or push-to-talk switch.
2. Defective RX power circuit.
3. Defective RX audio circuit.
4. Defective PLL circuit and/or channel switch.
5. Defective squelch.
6. Defective PA-CB MON switch and/or EXT-BOTH-INT Switch.

NO TRANSMISSION

1. Broken or bad contact in microphone connector and/or push-to-talk switch.
2. Broken or bad contact in antenna connector.
3. Defect in power supply.
4. Defect in PLL and/or Carrier Oscillator (Improper adjustment).
5. Inoperative microphone amplifier and/or balanced modulator in SSB mode.
6. Defective TX AMP.
(Between mixer and final stage)

NO MODULATION

1. Defective microphone.
2. Defective microphone connector.
3. Defective TR20 or IC4, (AM mode.)
4. Inoperative microphone amplifier, (both AM and SSB modes.)

FOR MORE HINTS, SEE BELOW:

NO RECEIVE SOUND

- A. Defective audio power IC, IC4.
Check Voltage at pin 9 of IC4; if approximately 6V, problem is not with this IC.
- B. Squelch is "ON" all the time.
If voltage at collector of TR14 is approx. 0.7V with Squelch Control in fully CCW, problem is not with squelch circuit.
If the voltage is approx. 1.7V, check TR14 and 15.

- C. Check whether the transceiver's signal strength meter deflects when a signal (27 MHz carrier with 1 kHz, 30% modulation, 100 μ V level) is applied to antenna.

1. The meter indicates "S-9".

You can assume that antenna through IF stage is OK.

NO AM Checks should be made on Detector (D21 and 22) ANL circuit (D24) and AF stage (TR13, VR403, TR36 and IC4).

NO SSB BUT AM OK..... Check frequency and level on TP3; if no signal, checks should be made on X-tals, TR22, 21 and 20.

NO SSB Checks should be made on Detector, TR13 and AF stage, VR403, TR36 and IC4.

2. No deflecting of meter.

Checks should be made on RF stage (TR9 and 10), IF stage (TR18, 17, 42 and 16) or AGC circuit (FET1, TR8, D13 and 14). Or trouble may be in PLL circuit. Check frequency on TP1; if it is as listed in Table, problem is not with PLL circuit.

NO NOISE BLANKER OPERATION

With NB Switch ON, apply a 27 MHz carrier signal to antenna. Then check DC voltage at TP6 varying the carrier signal from 1 μ V to 100 μ V.

- A. When TP6 voltage stays on and does not vary:
Check TR1,2,3,4,5, D1 and D2.
- B. When TP6 voltage varies from 0V to approx. 2V.
Check TR6, 7 and 8.
- C. If (A) and (B) are alright, L1 and/or L2 may be misaligned; go to alignment procedure for adjusting L1 and L2.

CHANNEL LED DOES NOT LIGHT

- A. When a specific segment fails to light, it is probable there is an open-circuit in the LED display or bad contact in the channel selector switch.
- B. When all segments fail to light, regulator circuit (TR23) is defective.

NO TRANSMISSION

- A. Check to see that voltage at pin 5 of IC5 is 13.8V on RX and 0V on TX; if not, check the microphone, its connection and TR37.
- B. Check to see that voltage at pin 8 of IC5 is 8V on TX; if not, the TX +B line (8V) is shorted to ground or IC5 is bad.

- C. Check the frequency at TP3; carrier oscillation may have stopped; if no carrier, check TR22, 21,20, D26 thru 31, X1 and X2.
- D. Carrier is OK, but no TX; check the frequency at TP1. If not same as listed in Frequency Table, PLL circuit defective. If OK, check IC3,6, TR38,39 and 41.
- E. If no TX on SSB modes and no modulation on AM mode, Mic amplifier or ALC/AMC section is defective. Check TR31,33,29 and TR28.

PLL TROUBLESHOOTING HINTS

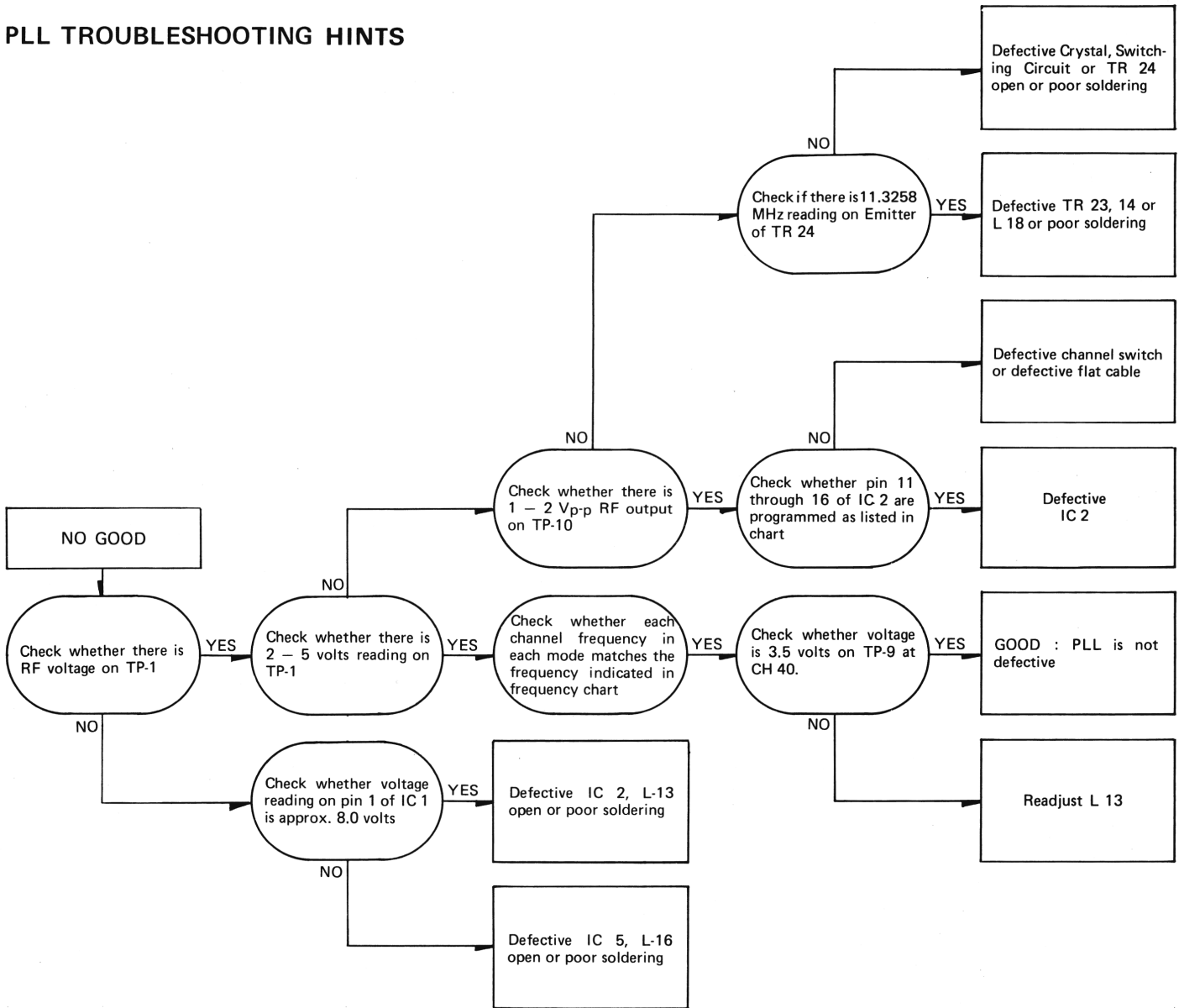

9. VOLTAGE CHART

Measurement condition: Following voltages were measured with no signal input.

IC1 UHIC-070

Pin No.	1	2	3	4	5	6	7	8	9	10
Voltage	7.8	0	0	0	3.0	0	0	8.0	7.3	4.0

IC2 MB8734 (at Channel 19)

Pin No.	1	2	3	4	5	6	7	8	9	10
Voltage	2.9	4.2	5.4	3.2	3.2	8.0	4.2	5.2	8.0	0
Pin No.	11	12	13	14	15	16	17	18		
Voltage	6.8	0	0	6.8	0.6	8.0	3.4	0		

IC3 AN612

Pin No.	1	2	3	4	5	6	7
Voltage	2.9	3.2	3.2	0	5.7	7.2	7.4

IC4 TA7222P

Pin No.	1	2	3	4	5	6	7	8	9	10
Voltage	13.8	2.9	0	0	1.8	1.8	0	0	6.8	13.1

IC5 MB3756

Pin No.	1	2	3	4	5	6	7	8
Voltage	8.0	13.8	8.0	0	13.8	8.0	-	0
Voltage	(8.0)	(13.8)	(8.0)	(0)	(0)	(0)	-	(8.0)

Remarks: Without () --- Receive mode
With () --- Transmit mode

IC6 SO42P

Pin No.	1	2	3	4	5	6	7	8	9	10
Voltage	0	7.8	7.8	0	7.8	0	2.8	2.8	0	1.5
Pin No.	11	12	13	14						
Voltage	1.4	1.5	1.4	0						

Remarks: Voltages of IC6 were measured on transmit mode.

FIELD EFFECT TRANSISTOR

FET 1 Gate 0.2 Source 2.8 Drain 8.0

Remarks: Voltages were measured on receive mode.

BIPOLAR TRANSISTOR

No.	Emitter	Base	Collector	Remarks
TR 1	0.5	1.2	7.8	RX, NB switch ON
2	0	0.7	2.4	RX, NB ON
3	1.6	2.4	6.8	RX, NB ON
4	0.5	0.5	8.0	RX, NB ON
5	0.5	0.4	8.0	RX, NB ON
6	0	0	7.4	RX, NB ON
7	8.0	7.4	0	RX, NB ON
8	0	0	0	
9	1.5	2.2	7.9	RX, RF Gain C.W.
	0	0.5	8.0	RX, RF Gain C.C.W.
10	0.1	0.3	7.9	RX
11	2.2	2.8	2.2	RX
	0	0	7.4	TX
12	0	0.5	8.0	RX
13	0.7	1.3	4.7	RX, SQ, C.C.W.
	1.7	1.4	7.9	RX, SQ, C.W.
14	8.0	8.0	0.7	RX, SQ, C.C.W.
	8.0	7.4	8.0	RX, SQ, C.W.
	0	0	0	TX
15	0.6	0	8.0	RX, SQ, C.C.W.
	1.1	2.5	7.4	RX, SQ, C.W.
16	2.1	2.9	7.1	RX
17	0	0.8	3.6	RX
18	1.5	2.2	6.8	RX
19	3.3	4.0	8.0	
20	0	0	7.5	TX, AM
	0	0	0.2	RX, AM
	0	0.8	0	TX and RX, SSB
21	0	0.8	0	TX, AM
	0	0.2	0	RX, AM
	0	0.1	0.3	TX and RX, USB only
	0	0.1	0	TX and RX, LSB only
22	1.6	2.3	7.6	
23	0.9	1.4	8.0	
24	2.8	3.5	6.5	
25	0	0	6.5	RX
	3.4	0	6.5	TX, AM
	1.6	0	6.5	TX, SSB
26	7.3	8	13.8	Brite
	2.6	3.2	13.8	Dim
27	0	0.2	2.9	RX, AM
	0	0	2.9	RX, SSB
	1.3	1.9	1.3	TX, AM
	0	0.1	2.8	TX, SSB
28	1.1	1.7	3.2	
29	0.3	1.0	1.7	
30	3.2	3.2	0	
	2.2	1.5	2.2	PA only

No.	Emitter	Base	Collector	Remarks
31	6.9	6.6	0.7	RX
	6.9	6.6	0	TX
32	0	0.7	0	RX
33	4.1	0.8	6.5	
	1.4	0.7	6.5	RX, AM only
34	13.8	6.1	13.8	
	4.8	5.6	13.0	RX, AM only
35	6.1	6.5	13.8	RX
	5.6	6.2	13.0	TX, AM
	6.1	6.5	13.8	TX, SSB
36	2.7	3.3	6.3	RX
37	7.6	7.8	13.8	RX
	0	0.6	0	TX
38	0.6	1.3	8.0	TX
39	0	0.2	13.2	RX
	0	0.7	5.3	TX, AM
	0	0.7	13.8	TX, SSB
40	1.0	1.2	2.1	TX
41	0	0	13.2	RX
	0	0.7	5.3	TX, AM
	0	0.7	13.8	TX, SSB
42	2.8	3.5	8.0	RX
47	0	0	6.8	TX AM/SSB
	0	0	0	RX
48	0	0	8	RX
	0	0.7	3.6	TX AM/SSB

10. IC INTERNAL DIAGRAMS

IC1 UHIC-070

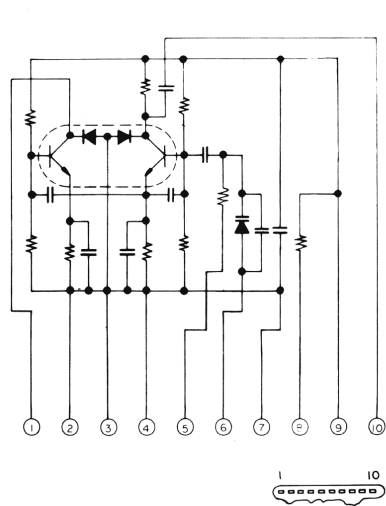

IC4 TA7222P

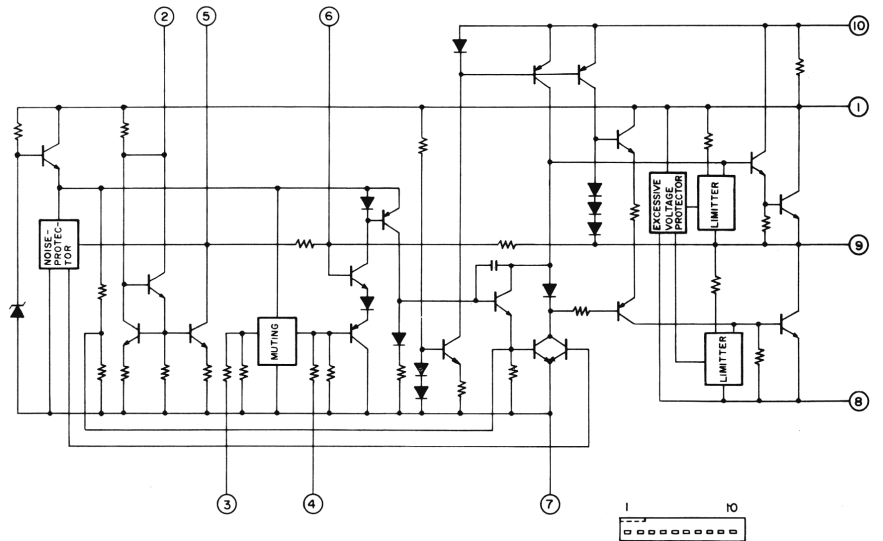

IC2 MB8734

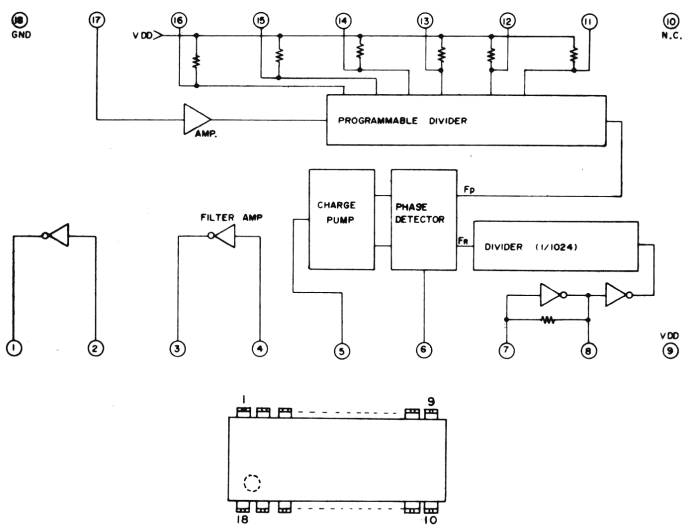

IC5 MB3756

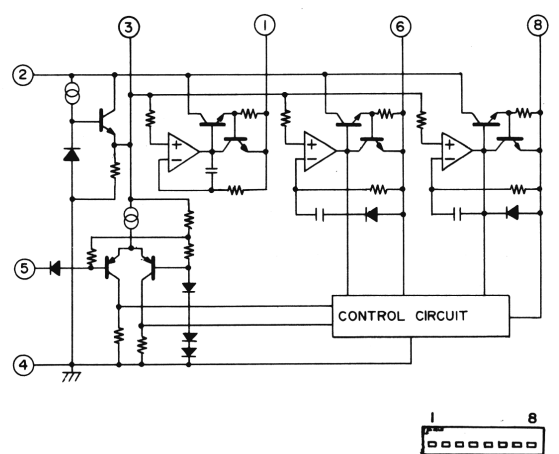

IC3 AN612

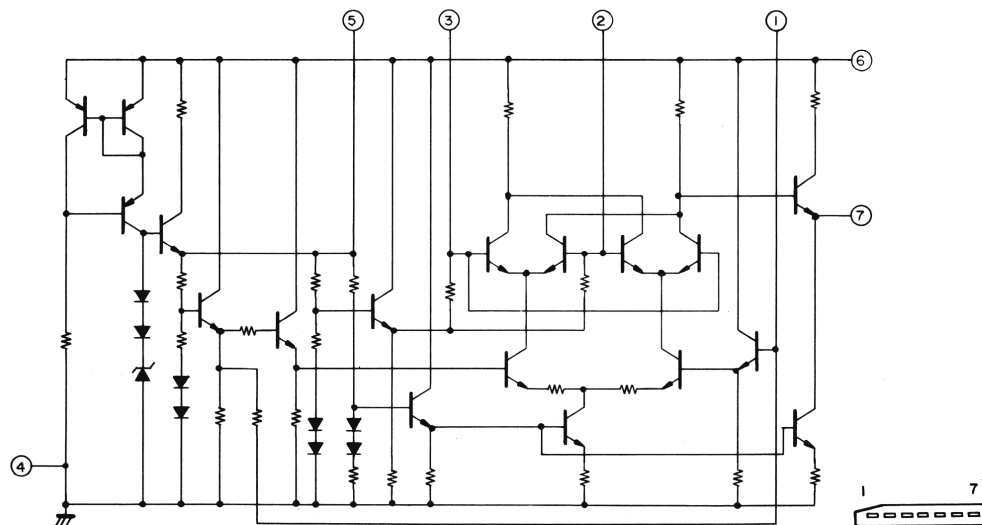

IC6 SO42P

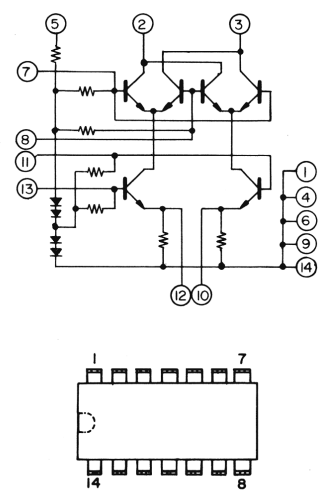

11. TRANSISTOR, DIODE, LED & COMPOUND PARTS LEAD IDENTIFICATION

2SA628-F
 2SC710-C
 2SC711-E
 2SC763-C
 2SC1312-F
 2SK19-BL

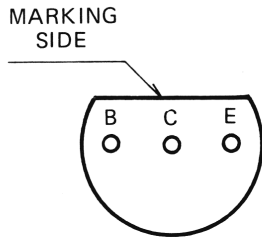
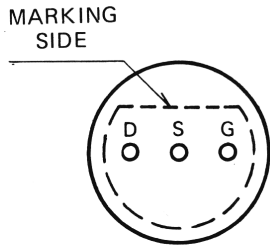

2SC 945A-Q
 2SC 1674-L
 2SC1730-L
 2SC1973

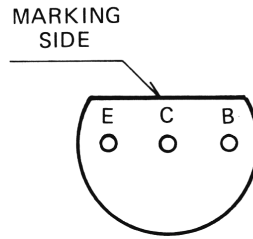

TLR-124

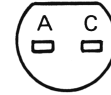

2SC 1306
 2SC 1969-B
 2SC 1419-C

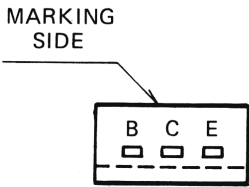

2SC 496-O

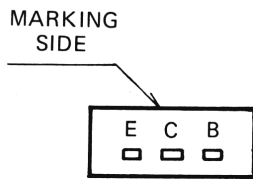

UR-202

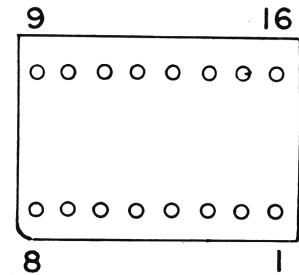
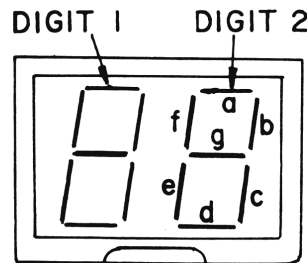

IN60, IN4003
 IS2687-D, MC 301
 IS2075-K, RD-20E-B1

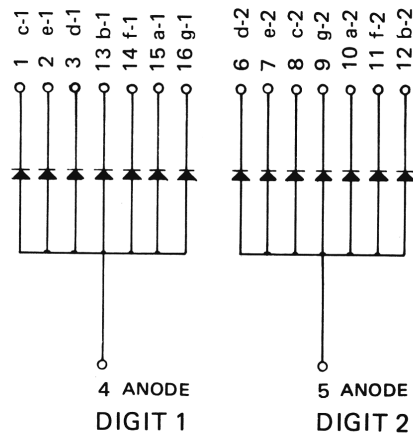
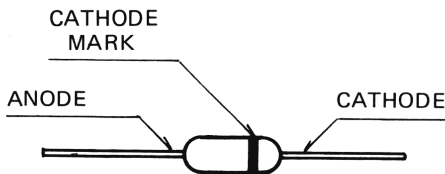

HA-003

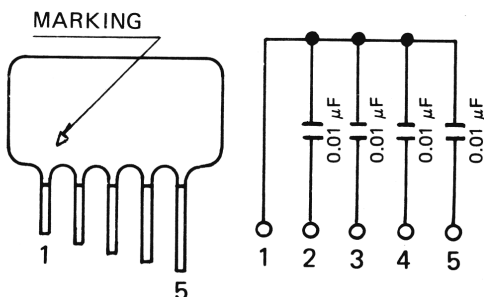

MV-1Y
 MV-13YH

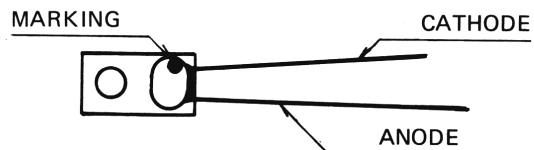

12. CHANNEL SWITCH P.C. BOARD

PC-616

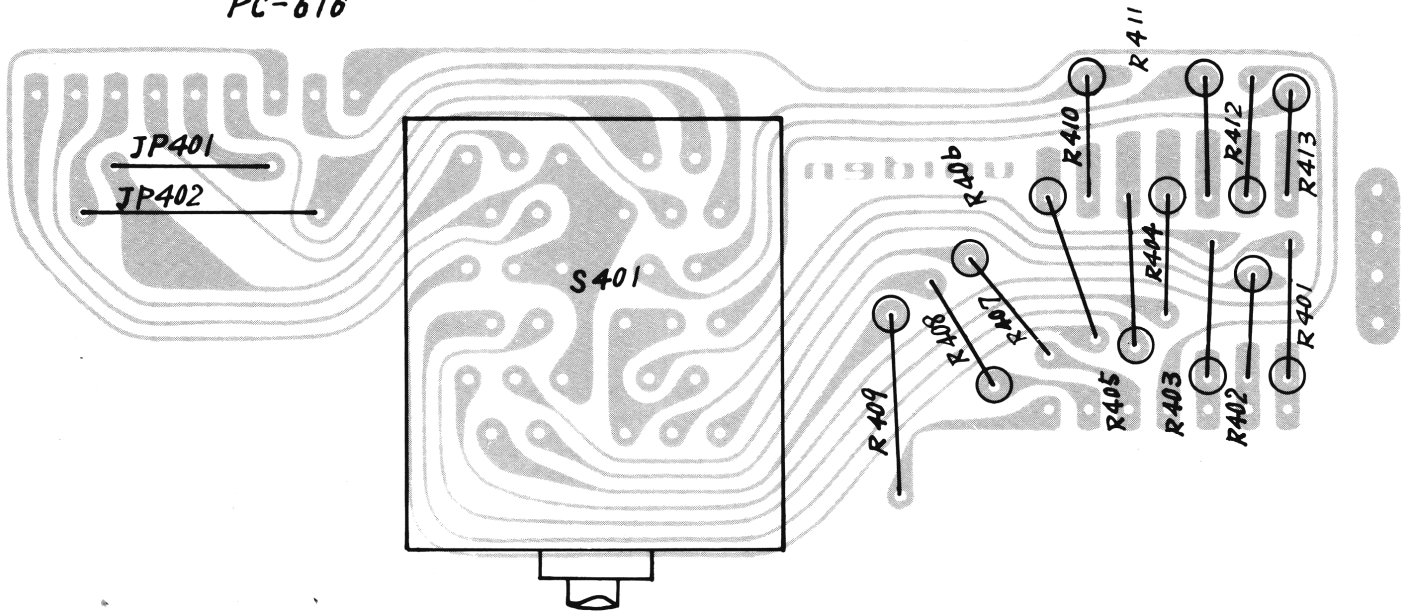

13. MIC P.C. BOARD

PC-465

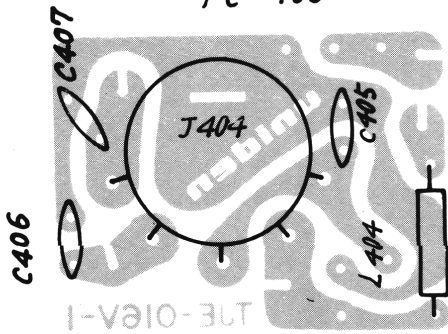

14. SLIDE SWITCH P.C. BOARD

PC-568

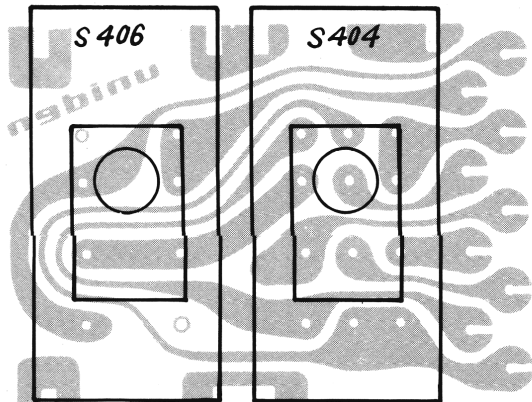

15. LED P.C. BOARD

PC-381

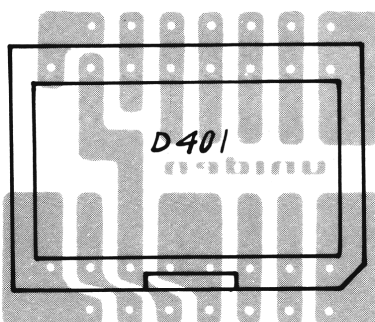

16. MAIN P.C. BOARD (TOP VIEW)

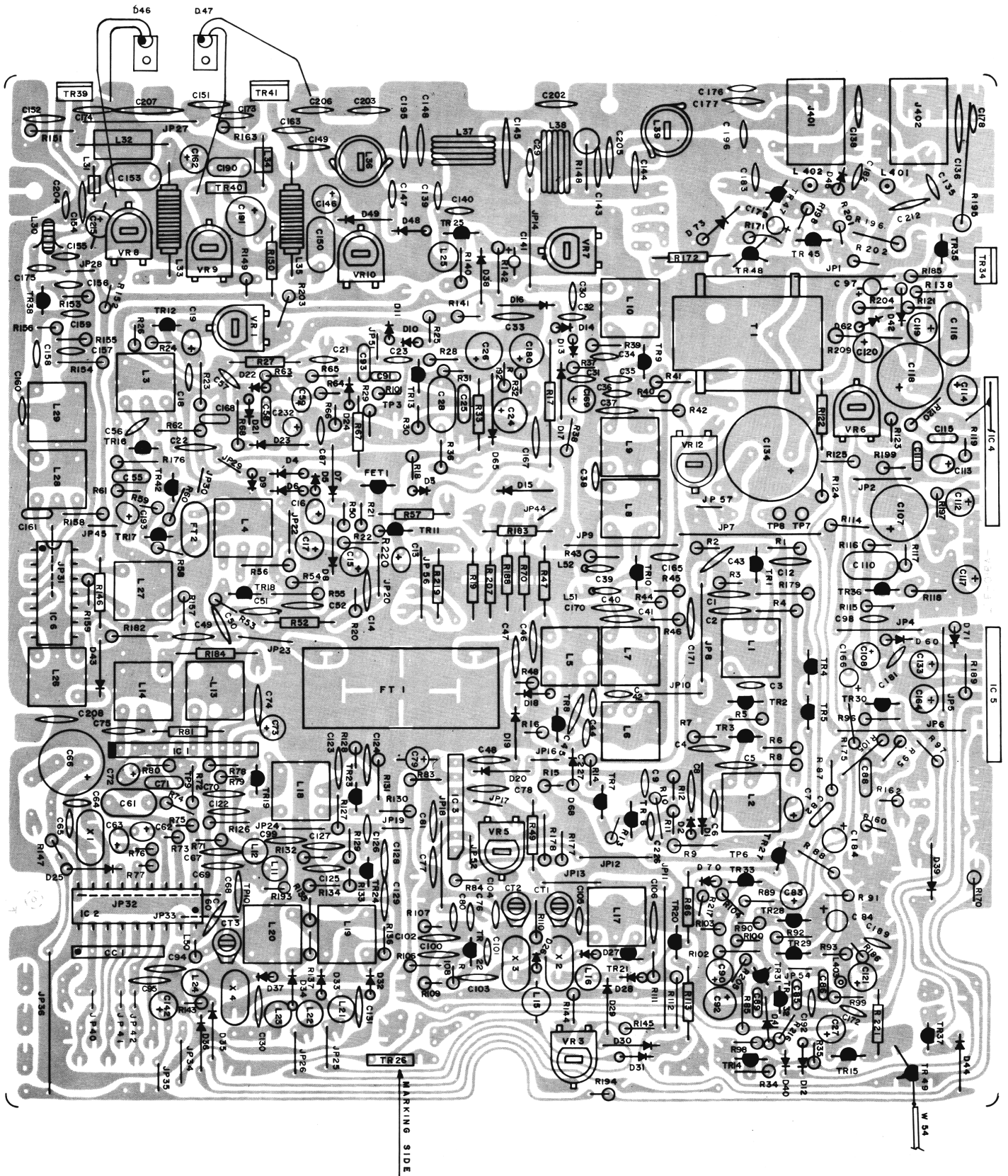

17. MAIN P.C. BOARD (BOTTOM VIEW)

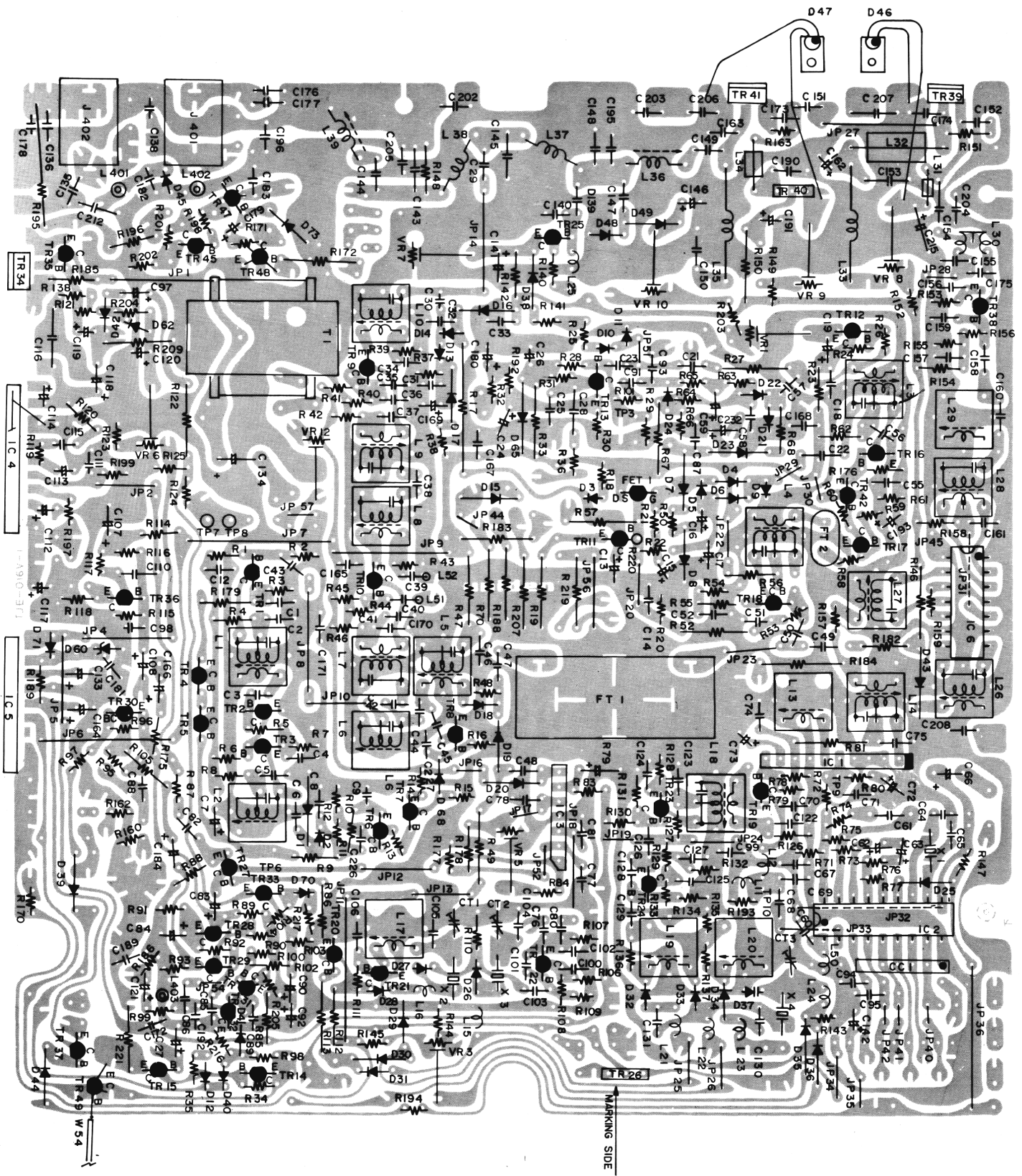

18. ADDITIONAL PARTS ON THE BOTTOM

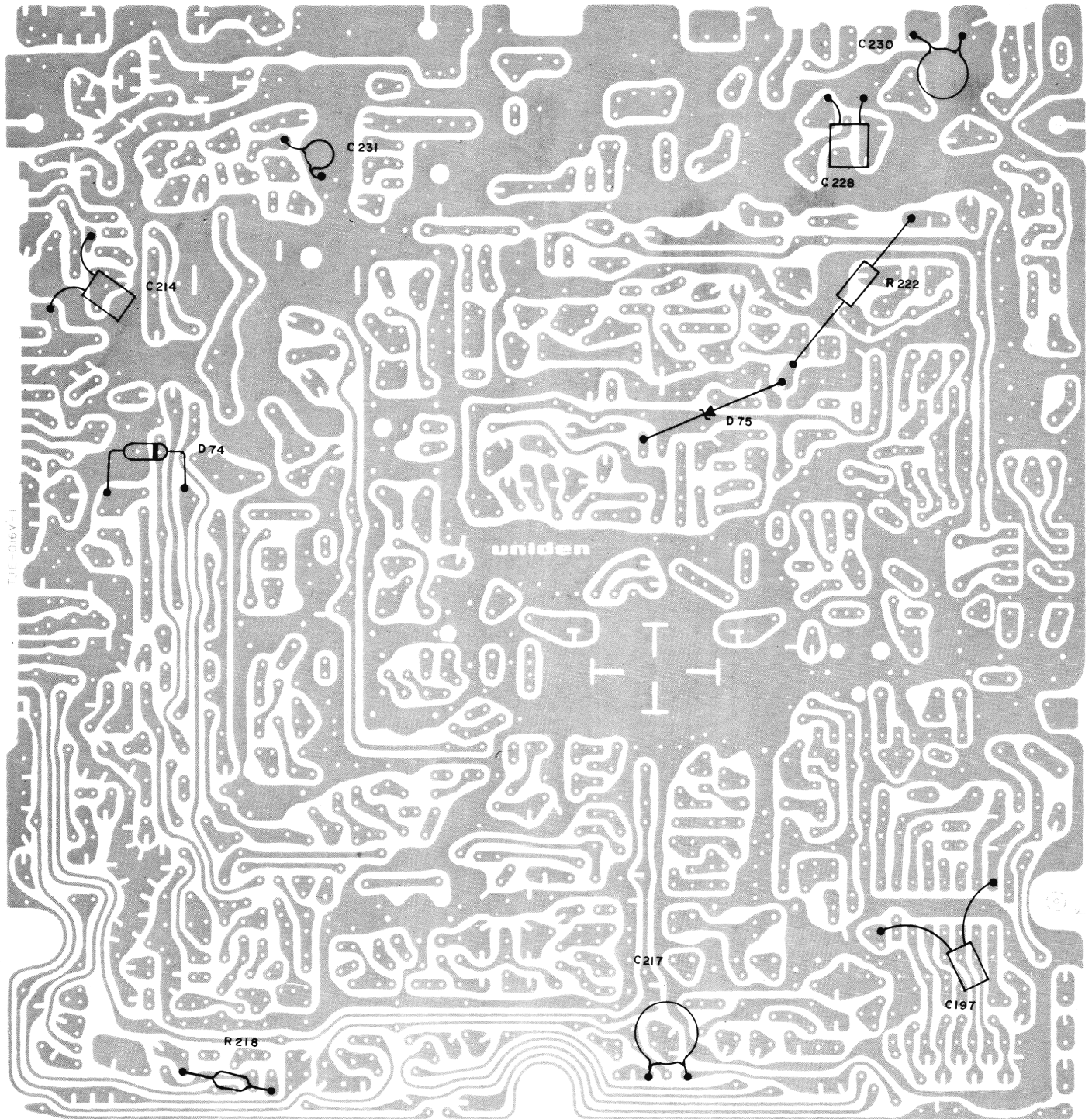

19. WIRING DIAGRAM

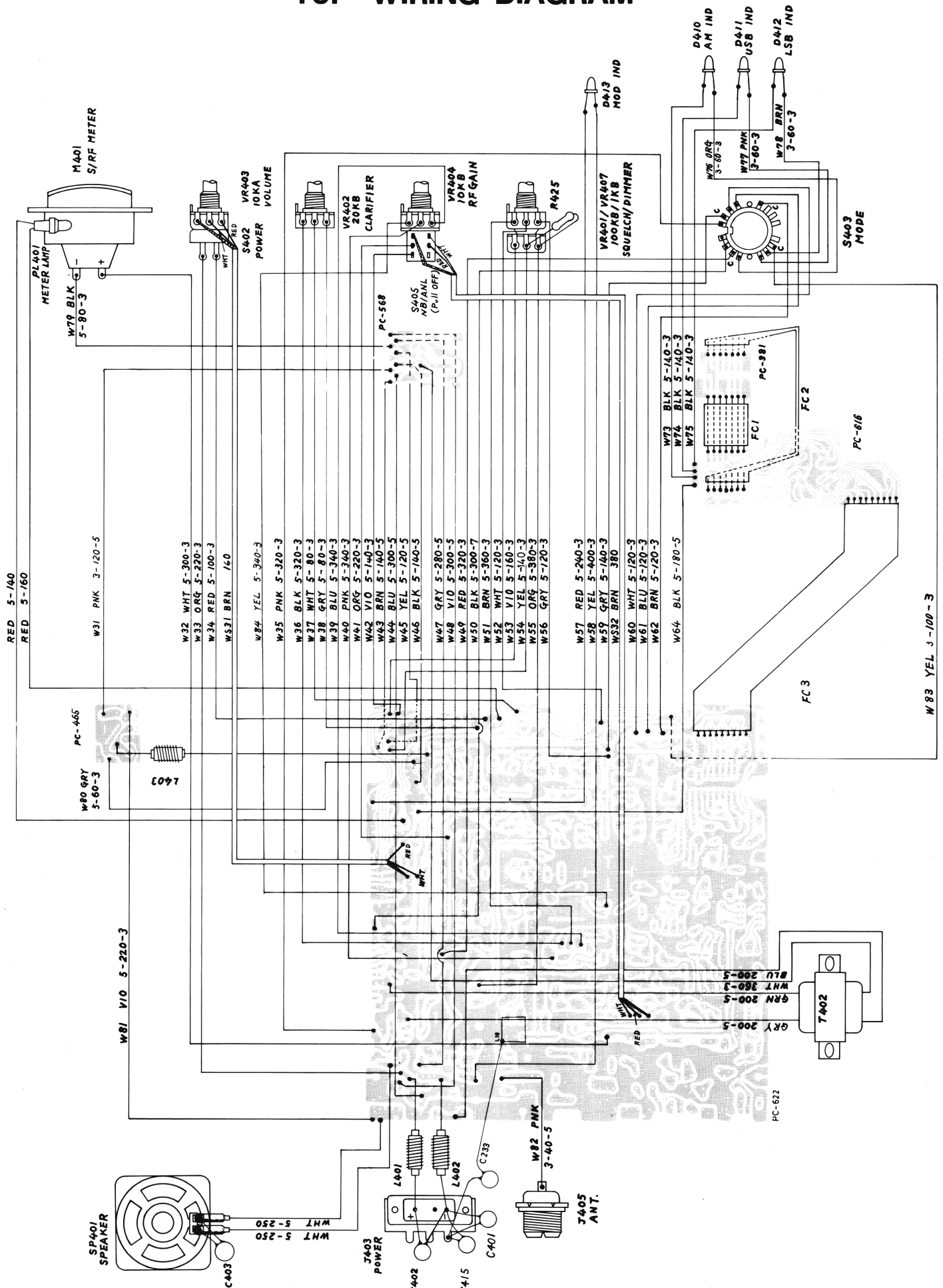

WIRING DIAGRAM

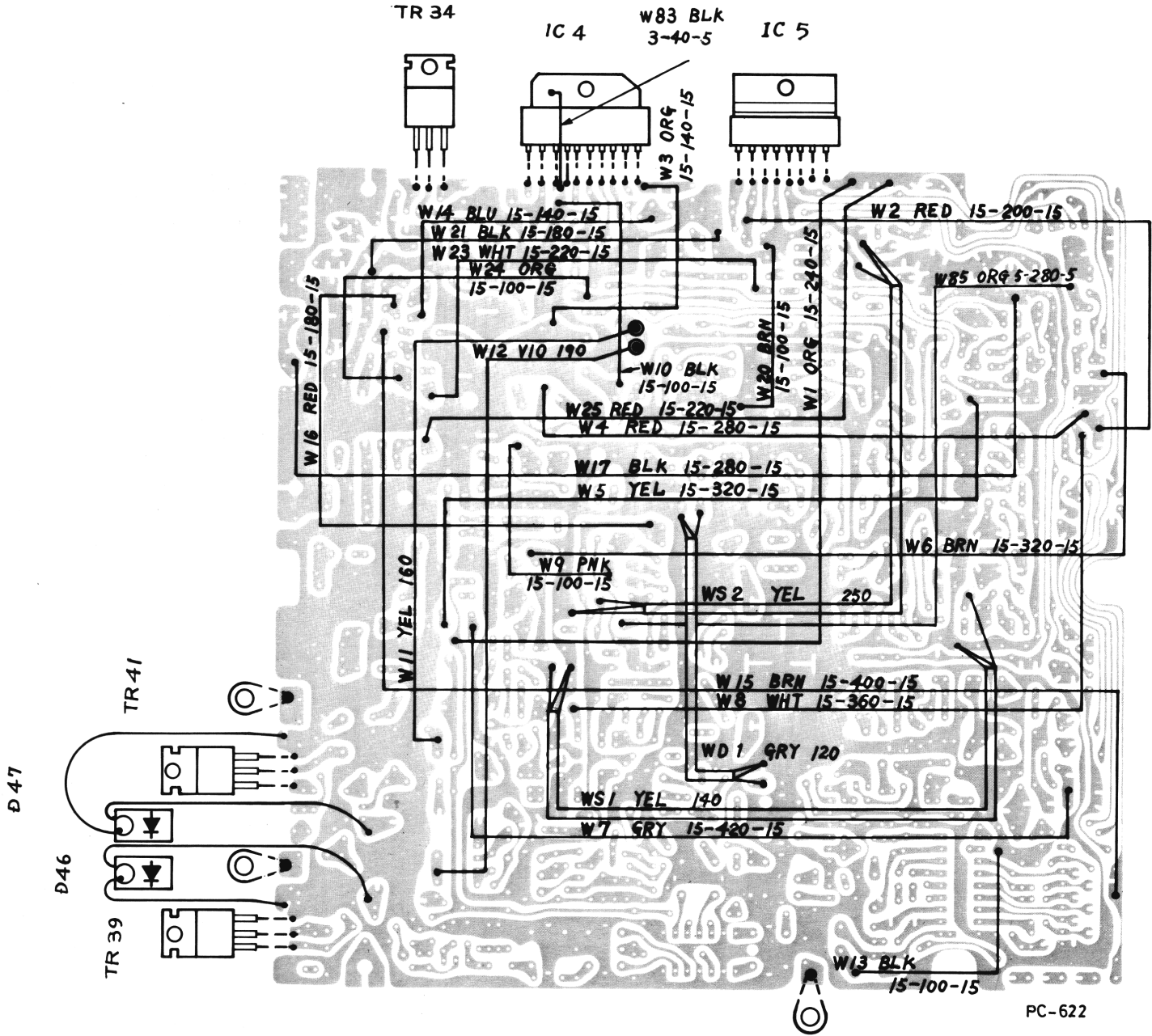

20. ELECTRICAL PARTS LIST

(See Page 30 & 31 for Capacitor Tolerance & Temp. Coding System)

REF. NO.	DESCRIPTION	RS. PART NO.	MFRS PART NO.
CAPACITORS			
C-1	Capacitor, Ceramic 0.022 μ F 50V Z YF	CF-2061	CKGZ 812230
C-2	Capacitor, Ceramic 0.022 μ F 50V Z YF	CF-2061	CKGZ 812230
C-3	Capacitor, Ceramic 0.001 μ F 50V M YD	CF-1559	CKDZ 811026
C-4	Capacitor, Ceramic 0.022 μ F 50V Z YF	CF-2061	CKGZ 812230
C-5	Capacitor, Ceramic 0.022 μ F 50V Z YF	CF-2061	CKGZ 812230
C-6	Capacitor, Ceramic 0.001 μ F 50V M YD	CF-1559	CKDZ 811026
C-7	Capacitor, Tantalum 0.22 μ F 25V M		CSEZ 512286
C-8	Capacitor, Ceramic 82 pF 50V K SL	CF-1847	CCGZ 818205
C-9	Capacitor, Ceramic 0.001 μ F 50V M YD	CF-1559	CKDZ 811026
C-12	Capacitor, Ceramic 0.022 μ F 50V Z YF	CF-2061	CKGZ 812230
C-13	Capacitor, Tantalum 0.1 μ F 25V M		CSEZ 511086
C-14	Capacitor, Ceramic 0.022 μ F 50V Z YF	CF-2061	CKGZ 812230
C-15	Capacitor, Electrolytic 2.2 μ F 25V Z		CELZ 512290
C-16	Capacitor, Electrolytic 2.2 μ F 25V Z		CELZ 512290
C-17	Capacitor, Electrolytic 0.47 μ F 50V Z		CELZ 814780
C-18	Capacitor, Ceramic 0.022 μ F 50V M YF	CF-2061	CKGZ 812230
C-19	Capacitor, Tantalum 0.22 μ F 25V M		CSEZ 512286
C-21	Capacitor, Ceramic 5 pF 50V C SL	CF-1100	CCGZ 815091
C-22	Capacitor, Ceramic 5 pF 50V C SL	CF-1100	CCGZ 815091
C-23	Capacitor, Ceramic 1 pF 50V C SL	CF-1015	CCGZ 811091
C-24	Capacitor, Electrolytic 47 μ F 10V Z		CELZ 114700
C-25	Capacitor, Mylar 0.033 μ F 50V K		QOMZ813335
C-26	Capacitor, Electrolytic 47 μ F 10V Z		CELZ 114700
C-27	Capacitor, Electrolytic 0.47 μ F 50V Z		CELZ 814780
C-28	Capacitor, Mylar 0.1 μ F 50V K		QOMZ811045
C-29	Capacitor, Ceramic 12 pF 50V K SL	CF-1182	CCGZ 811205
C-30	Capacitor, Ceramic 0.001 μ F 50V M YD	CF-1559	CKDZ 811026
C-31	Capacitor, Ceramic 0.001 μ F 50V M YD	CF-1519	CKDZ 811026
C-32	Capacitor, Ceramic 0.001 μ F 50V M YD	CF-1519	CKDZ 811026
C-33	Capacitor, Ceramic 0.0047 μ F 50V M YD	CF-1679	CKDZ 814726
C-34	Capacitor, Ceramic 0.001 μ F 50V M YD	CF-1519	CKDZ 811026
C-35	Capacitor, Ceramic 0.0047 μ F 50V M YD	CF-1679	CKDZ 814726
C-36	Capacitor, Ceramic 4 pF 50V C SL	CF-1689	CCGZ 814091
C-37	Capacitor, Ceramic 0.0047 μ F 50V M YD	CF-1679	CKDZ 814726
C-38	Capacitor, Ceramic 2 pF 50V C CJ	CF-2065	CCBZ 812091
C-39	Capacitor, Ceramic 0.001 μ F 50V M YD	CF-1519	CKDZ 811026
C-40	Capacitor, Ceramic 0.001 μ F 50V M YD	CF-1519	CKDZ 811026
C-41	Capacitor, Ceramic 0.001 μ F 50V M YD	CF-1519	CKDZ 811026
C-42	Capacitor, Ceramic 2 pF 50V C CJ	CF-2065	CCBZ 812091
C-43	Capacitor, Ceramic 33 pF 50V K SL	CF-1315	CCGZ 813305
C-44	Capacitor, Ceramic 2 pF 50V C CJ	CF-2065	CCBZ 812091
C-45	Capacitor, Ceramic 0.022 μ F 50V Z YF	CF-2061	CKGZ 812230
C-46	Capacitor, Ceramic 0.022 μ F 50V Z YF	CF-2061	CKGZ 812230
C-47	Capacitor, Ceramic 0.022 μ F 50V Z YF	CF-2061	CKGZ 812230
C-48	Capacitor, Ceramic 0.01 μ F 50V M YD	CF-1709	CKDZ 811036
C-49	Capacitor, Ceramic 0.022 μ F 50V Z YF	CF-2061	CKGZ 812230
C-50	Capacitor, Ceramic 0.022 μ F 50V Z YF	CF-2061	CKGZ 812230
C-51	Capacitor, Ceramic 0.022 μ F 50V Z YF	CF-2061	CKGZ 812230
C-52	Capacitor, Ceramic 0.022 μ F 50V Z YF	CF-2061	CKGZ 812230
C-55	Capacitor, Mylar 0.022 μ F 50V K		QOMZ812235
C-56	Capacitor, Ceramic 0.022 μ F 50V Z YF	CF-2061	CKGZ 812230
C-57	Capacitor, Ceramic 27 pF 50V K SL	CF-1269	CCGZ 812705
C-58	Capacitor, Mylar 0.001 μ F 50V K		QOMZ811025
C-59	Capacitor, Tantalum 1 μ F 25V M		CSEZ 511096
C-60	Capacitor, Ceramic 0.01 μ F 50V M YD	CF-1709	CKDZ 811036
C-61	Capacitor, Mylar 0.1 μ F 50V K		QOMZ811045

REF. NO.	DESCRIPTION	RS. PART NO.	MFRS PART NO.
C-62	Capacitor, Tantalum 2.2 μ F 25V M		CSEZ 512296
C-63	Capacitor, Tantalum 2.2 μ F 25V M		CSEZ 512296
C-64	Capacitor, Ceramic 18 pF 50V K CH	CF-1225	CCCZ 811805
C-65	Capacitor, Ceramic 10 pF 50V D CH	CF-1141	CCCZ 811002
C-66	Capacitor, Electrolytic 1000 μ F 10V Z		CELZ 111020
C-67	Capacitor, Ceramic 0.01 μ F 50V M YD	CF-1709	CKDZ 811036
C-68	Capacitor, Ceramic 0.0022 μ F 50V Z YF	CF-2061	CKGZ 812230
C-69	Capacitor, Ceramic 47 pF 50V K SL	CF-1366	CCGZ 814705
C-70	Capacitor, Ceramic 47 pF 50V K SL	CF-1366	CCGZ 814705
C-71	Capacitor, Mylar 0.047 μ F 50V K		CQMZ 814735
C-72	Capacitor, Tantalum 4.7 μ F 10V M		CSEZ 114796
C-73	Capacitor, Electrolytic 4.7 μ F 25V Z		CELZ 514790
C-74	Capacitor, Ceramic 0.01 μ F 50V M YD	CF-1709	CKDZ 811036
C-75	Capacitor, Ceramic 0.01 μ F 50V M YD	CF-1709	CKDZ 811036
C-76	Capacitor, Ceramic 15 pF 50V K CH	CF-1190	CCCZ 811505
C-77	Capacitor, Ceramic 0.01 μ F 50V M YD	CF-1709	CKDZ 811036
C-78	Capacitor, Ceramic 0.01 μ F 50V M YD	CF-1709	CKDZ 811036
C-79	Capacitor, Electrolytic 47 μ F 10V Z		CELZ 114700
C-80	Capacitor, Ceramic 4 pF 50V C SL	CF-1089	CCGZ 814091
C-81	Capacitor, Ceramic 270 pF 50V K SL	CF-1504	CCGZ 812715
C-82	Capacitor, Mylar 0.01 μ F 50V K		CQMZ 811035
C-83	Capacitor, Electrolytic 2.2 μ F 25V Z		CELZ 512290
C-84	Capacitor, Electrolytic 100 μ F 6.3V Z		CELZ 901010
C-85	Capacitor, Mylar 0.0022 μ F 50V K		CQMZ 812225
C-86	Capacitor, Mylar 0.0068 μ F 50V K		CQMZ 816825
C-87	Capacitor, Ceramic 0.022 μ F 50V Z YF	CF-2061	CKGZ 812230
C-88	Capacitor, Mylar 0.022 μ F 50V K		CQMZ 812235
C-89	Capacitor, Mylar 0.01 μ F 50V K		CQMZ 811035
C-90	Capacitor, Tantalum 10 μ F 35V M		CSEZ 661006
C-91	Capacitor, Mylar 0.001 μ F 50V K		CQMZ 811025
C-92	Capacitor, Electrolytic 47 μ F 10V Z		CELZ 114700
C-93	Capacitor, Mylar 0.01 μ F 50V K		CQMZ 811035
C-94	Capacitor, Ceramic 0.01 μ F 50V M YD	CF-1709	CKDZ 811036
C-95	Capacitor, Ceramic 0.01 μ F 50V M YD	CF-1709	CKDZ 811036
C-97	Capacitor, Electrolytic 10 μ F 16V Z		CELZ 311000
C-98	Capacitor, Ceramic 0.001 μ F 50V M YD	CF-1559	CKDZ 811026
C-99	Capacitor, Ceramic 0.01 μ F 50V M YD	CF-1709	CKDZ 811036
C-100	Capacitor, Ceramic 0.01 μ F 50V M YD	CF-1709	CKDZ 811036
C-101	Capacitor, Ceramic 470 pF 50V K SL	CF-1519	CCGZ 814715
C-102	Capacitor, Ceramic 100 pF 50V K SL		CCGZ 811015
C-103	Capacitor, Ceramic 0.01 μ F 50V M YD	CF-1709	CKDZ 811036
C-104	Capacitor, Ceramic 18 pF 50V K CH	CF-1225	CCCZ 811805
C-105	Capacitor, Ceramic 10 pF 50V D CJ	CF-2064	CCBZ 811002
C-106	Capacitor, Ceramic 0.01 μ F 50V M YD	CF-1709	CKDZ 811036
C-107	Capacitor, Electrolytic 220 μ F 10V Z		CELZ 112210
C-108	Capacitor, Electrolytic 0.47 μ F 50V Z		CELZ 814780
C-110	Capacitor, Mylar 0.01 μ F 50V K		CQMZ 811035
C-111	Capacitor, Mylar 0.022 μ F 50V K		CQMZ 812235
C-112	Capacitor, Electrolytic 4.7 μ F 25V Z		CELZ 514790
C-113	Capacitor, Tantalum 22 μ F 6.3V M		CSEZ 902206
C-114	Capacitor, Electrolytic 47 μ F 10V Z		CELZ 114700
C-115	Capacitor, Mylar 0.001 μ F 50V K		CQMZ 811025
C-116	Capacitor, Mylar 0.1 μ F 50V K		CQMZ 811045
C-117	Capacitor, Electrolytic 10 μ F 25V Z		CELZ 511000
C-118	Capacitor, Electrolytic 470 μ F 10V Z		CELZ 114710
C-119	Capacitor, Electrolytic 1 μ F 50V Z		CELZ 811090
C-120	Capacitor, Electrolytic 10 μ F 16V Z		CELZ 311000
C-121	Capacitor, Electrolytic 0.47 μ F 50V Z		CELZ 814780

The second code indicates variation of capacitance against temperature; YA = ±5%, YB = ±10%, YD = +20
+20 -30%, YE = +20 -50%, YF = +30 -80%, (-20 ~ +85°C), ZF = +30 -80% (-10 ~ +70°C), CH =
0±60ppm/°C, RH = -220ppm/°C±60ppm/°C, TH = -4700ppm/°C, SL = +350ppm/°C ~ -1000ppm/°C,
UJ = -750ppm/°C±120ppm/°C

REF. NO.	DESCRIPTION	RS. PART NO.	MFRS PART NO.
C-122	Capacitor, Ceramic 0.01 μF 50V M YD	CF-1709	CKDZ 811036
C-123	Capacitor, Ceramic 0.01 μF 50V M YD	CF-1709	CKDZ 811036
C-124	Capacitor, Ceramic 0.01 μF 50V M YD	CF-1709	CKDZ 811036
C-125	Capacitor, Ceramic 0.01 μF 50V M YD	CF-1709	CKDZ 811036
C-126	Capacitor, Ceramic 10 pF 50V D SL	CF-1815	CCGZ 811002
C-127	Capacitor, Ceramic 220 pF 50V K SL	CF-1490	CCGZ 812215
C-128	Capacitor, Ceramic 470 pF 50V K SL	CF-1519	CCGZ 814715
C-129	Capacitor, Ceramic 0.01 μF 50V M YD	CF-1709	CKDZ 811036
C-130	Capacitor, Ceramic 0.01 μF 50V M YD	CF-1709	CKDZ 811036
C-131	Capacitor, Ceramic 0.01 μF 50V M YD	CF-1709	CKDZ 811036
C-133	Capacitor, Electrolytic 10 μF 16V Z		CELZ 311000
C-134	Capacitor, Electrolytic 1000 μF 25V Z		CELZ 511020
C-135	Capacitor, Ceramic 0.0047 μF 50V M YD	CF-1679	CKDZ 814726
C-136	Capacitor, Ceramic 0.0047 μF 50V M YD	CF-1679	CKDZ 814726
C-138	Capacitor, Ceramic 0.0047 μF 50V M YD	CF-1679	CKDZ 814726
C-139	Capacitor, Ceramic 1 pF 50V C SL	CF-1015	CCGZ 811091
C-140	Capacitor, Ceramic 10 pF 50V D CH	CF-1141	CCCZ 811002
C-141	Capacitor, Electrolytic 2.2 μF 25V Z		CELZ 512290
C-142	Capacitor, Electrolytic 0.47 μF 50V Z		CELZ 814780
C-143	Capacitor, Ceramic 68 pF 50V K SL	CF-1959	CCGZ 816805
C-144	Capacitor, Ceramic 39 pF 50V K SL	CF-1816	CCGZ 813905
C-145	Capacitor, Ceramic 180 pF 50V K SL	CF-1470	CCGZ 811815
C-146	Capacitor, Electrolytic 1 μF 50V Z		CELZ 811090
C-147	Capacitor, Ceramic 1 pF 50V C SL	CF-1015	CCGZ 811091
C-148	Capacitor, Ceramic 390 pF 50V K SL	CF-1934	CCGZ 813915
C-149	Capacitor, Ceramic 330 pF 50V K UJ	CF-1985	CCUZ 813315
C-150	Capacitor, Mylar 0.1 μF 50V K		CQMZ811045
C-151	Capacitor, Ceramic 470 pF 50V K SL	CF-1519	CCGZ 814715
C-152	Capacitor, Ceramic 0.0047 μF 50V M YD	CF-1679	CKDZ 814726
C-153	Capacitor, Mylar 0.1 μF 50V K		CQMZ811045
C-154	Capacitor, Ceramic 0.0047 μF 50V M YD	CF-1679	CKDZ 814726
C-155	Capacitor, Ceramic 0.0047 μF 50V M YD	CF-1679	CKDZ 814726
C-156	Capacitor, Ceramic 0.0047 μF 50V M YD	CF-1679	CKDZ 814726
C-157	Capacitor, Ceramic 0.0047 μF 50V M YD	CF-1679	CKDZ 814726
C-158	Capacitor, Ceramic 47 pF 50V K CH	CF-1365	CCCZ 814705
C-159	Capacitor, Ceramic 330 pF 50V K UJ	CF-1985	CCUZ 813315
C-160	Capacitor, Ceramic 2 pF 50V C CJ	CF-2065	CCBZ 812091
C-161	Capacitor, Mylar 0.01 μF 50V K		CQMZ811035
C-162	Capacitor, Electrolytic 1 μF 50V Z		CELZ 811090
C-163	Capacitor, Ceramic 120 pF 50V K SL	CF-1440	CCGZ 811215
C-164	Capacitor, Electrolytic 10 μF 25V Z		CELZ 511000
C-165	Capacitor, Ceramic 0.001 μF 50V M YD	CF-1559	CKDZ811026
C-166	Capacitor, Electrolytic 0.47 μF 50V Z		CELZ 814780
C-167	Capacitor, Ceramic 0.022 μF 50V Z YF	CF-2061	CKGZ812230
C-168	Capacitor, Mylar 0.047 μF 50V K		CQMZ814735
C-169	Capacitor, Electrolytic 1 μF 50V Z		CELZ 811090
C-170	Capacitor, Ceramic 100 pF 50V K SL		CCGZ 811015
C-171	Capacitor, Ceramic 56 pF 50V K SL	CF-1373	CCGZ 815605
C-172	Capacitor, Ceramic 0.001 μF 50V M YD	CF-1559	CKDZ 811026
C-173	Capacitor, Ceramic 0.0047 μF 50V M YD	CF-1679	CKDZ814726
C-174	Capacitor, Ceramic 330 pF 50V K SL	CF-1514	CCGZ 813315
C-175	Capacitor, Ceramic 47 pF 50V K SL	CF-1315	CCGZ 814705
C-176	Capacitor, Ceramic 0.001 μF 50V M YD	CF-1559	CKDZ811026
C-177	Capacitor, Ceramic 0.022 μF 50V Z YF	CF-2061	CKGZ812230
C-178	Capacitor, Ceramic 0.001 μF 50V M YD	CF-1559	CKDZ811026
C-179	Capacitor, Electrolytic 10 μF 16V Z		CELZ 311000
C-180	Capacitor, Electrolytic 22 μF 10V Z		CELZ 112200
C-181	Capacitor, Ceramic 0.01 μF 50V M YD	CF-1709	CKDZ811036

REF. NO.	DESCRIPTION	RS. PART NO.	MFRS PART NO.
C-182	Capacitor, Ceramic 0.047 μ F 50V Z ZF	CF-2062	CKCZ 814730
C-183	Capacitor, Ceramic 0.0047 μ F 50V M YD	CF-1679	CKDZ 814726
C-184	Capacitor, Electrolytic 0.47 μ F 50V Z		CELZ 814780
C-189	Capacitor, Ceramic 0.01 μ F 50V M YD	CF-1709	CKDZ 811036
C-190	Capacitor, Mylar 0.047 μ F 50V K		CQMZ 814735
C-191	Capacitor, Electrolytic 47 μ F 10V Z		CELZ 114700
C-192	Capacitor, Ceramic 0.001 μ F 50V M YD	CF-1559	CKDZ 811026
C-193	Capacitor, Electrolytic 1 μ F 50V Z		CELZ 811090
C-195	Capacitor, Ceramic 47 pF 50V K SL	CF-1366	CCGZ 814705
C-196	Capacitor, Ceramic 0.01 μ F 50V M YD	CF-1709	CKDZ 811036
C-197	Capacitor, Mylar 0.0047 μ F 50V K		CQMZ 814725
C-202	Capacitor, Ceramic 0.0047 μ F 50V M YD	CF-1679	CKDZ 814726
C-203	Capacitor, Ceramic 0.0047 μ F 50V M YD	CF-1679	CKDZ 814726
C-204	Capacitor, Ceramic 0.022 μ F 50V Z YF	CF-2061	CKGZ 812230
C-205	Capacitor, Ceramic 0.01 μ F 50V M YD	CF-1709	CKDZ 811036
C-206	Capacitor, Ceramic 0.022 μ F 50V Z YF	CF-2061	CKGZ 812230
C-207	Capacitor, Ceramic 0.1 μ F 50V Z ZF	CF-2063	CKCZ 811040
C-208	Capacitor, Ceramic 0.022 μ F 50V Z YF	CF-2061	CKGZ 812230
C-212	Capacitor, Ceramic 0.01 μ F 50V M YD	CF-1709	CKDZ 811036
C-214	Capcitor, Mylar 0.047 μ F 50V K		CQMZ 814735
C-215	Capacitor, Electrolytic 47 μ F 10V Z		CELZ 114700
C-217	Capacitor, Ceramic 0.022 μ F 50V Z YF	CF-2061	CKGZ 812230
C-226	Capacitor, Ceramic 330 pF 50V K SL	CF-1514	CCGZ 813315
C-227	Capacitor, Ceramic 330 pF 50V K SL	CF-1514	CCGZ 813315
C-228	Capacitor, Mylar 0.1 μ F 50V K		CQMZ 811045
C-230	Capacitor, Ceramic 0.01 μ F 50V M YD		CKDZ 811036
C-231	Capacitor, Ceramic 0.001 μ F 50V M YD		CKDZ 811026
C-232	Capacitor, Electrolytic 4.7 μ F 25V Z		CELZ 514790
C-233	Capacitor, Ceramic 0.001 μ F 50V M YD		CKDZ 811026
C-401	Capacitor, Ceramic 0.01 μ F 50V M YD	CF-1709	CKDZ 811036
C-402	Capacitor, Ceramic 0.022 μ F 50V Z YF	CF-2061	CKGZ 812230
C-403	Capacitor, Ceramic 0.001 μ F 50V M YD	CF-1559	CKDZ 811026
C-405	Capacitor, Ceramic 0.001 μ F 50V M YD	CF-1559	CKDZ 811026
C-406	Capacitor, Ceramic 0.001 μ F 50V M YD	CF-1559	CKDZ 811026
C-407	Capacitor, Ceramic 0.001 μ F 50V M YD	CF-1559	CKDZ 811026
C-415	Capacitor, Ceramic 0.001 μ F 50V M YD	CF-1559	CKDZ 811026
CT-1	Capacitor, Trimmer 20 pF CV-028	C-0790	CCVY 028004
CT-2	Capacitor, Trimmer 20 pF CV-028	C-0790	CCVY 028004
CT-3	Capacitor, Trimmer 20 pF CV-028	C-0790	CCVY 028004
CC-1	Compound Parts 0.01 μ F HA-003	C-0793	HHAY003001
DIODES			
D-1	Diode, 1N60	DX-0161	DDAY001004
D-2	Diode, 1N60	DX-0161	DDAY001004
D-3	Diode, 1S2075K	DX-1118	DDAY063001
D-4	Diode, 1S2075K	DX-1118	DDAY063001
D-5	Diode, 1S2075K	DX-1118	DDAY063001
D-6	Diode, 1S2075K	DX-1118	DDAY063001
D-7	Diode, 1S2075K	DX-1118	DDAY063001
D-8	Diode, 1S2075K	DX-1118	DDAY063001
D-9	Diode, 1S2075K	DX-1118	DDAY063001
D-10	Diode, 1S2075K	DX-1118	DDAY063001
D-11	Diode, 1S2075K	DX-1118	DDAY063001
D-12	Diode, 1S2075K	DX-1118	DDAY063001
D-13	Diode, MC-301	DX-0985	DDAY090001

REF. NO.	DESCRIPTION		RS. PART NO.	MFRS PART NO.
D-14	Diode,	MC-301	DX-0985	DDAY 090001
D-15	Diode,	1S2075K	DX-1118	DDAY 063001
D-16	Diode,	1S2075K	DX-1118	DDAY 063001
D-17	Diode,	1S2075K	DX-1118	DDAY 063001
D-18	Diode,	1S2075K	DX-1118	DDAY 063001
D-19	Diode,	1S2075K	DX-1118	DDAY 063001
D-20	Diode,	1S2075K	DX-1118	DDAY 063001
D-21	Diode,	1N60	DX-0161	DDAY 001004
D-22	Diode,	1N60	DX-0161	DDAY 001004
D-23	Diode,	1S2075K	DX-1118	DDAY 063001
D-24	Diode,	1S2075K	DX-1118	DDAY 063001
D-25	Diode,	1S2075K	DX-1118	DDAY 063001
D-26	Diode,	1S2075K	DX-1118	DDAY 063001
D-27	Diode,	1S2075K	DX-1118	DDAY 063001
D-28	Diode,	1S2075K	DX-1118	DDAY 063001
D-29	Diode,	1S2075K	DX-1118	DDAY 063001
D-30	Diode,	1S2075K	DX-1118	DDAY 063001
D-31	Diode,	1S2075K	DX-1118	DDAY 063001
D-32	Diode,	1S2075K	DX-1118	DDAY 063001
D-33	Diode,	1S2075K	DX-1118	DDAY 063001
D-34	Diode,	1S2075K	DX-1118	DDAY 063001
D-35	Diode,	1S2075K	DX-1118	DDAY 063001
D-36	Diode,	1S2075K	DX-1118	DDAY 063001
D-37	Diode, Vari-Cap,	1S2687-D	DX-0749	DDAY 067001
D-38	Diode,	1S2075K	DX-1118	DDAY 063001
D-39	Diode,	1S2075K	DX-1118	DDAY 063001
D-40	Diode,	1S2075K	DX-1118	DDAY 063001
D-41	Diode,	1S2075K	DX-1118	DDAY 063001
D-42	Diode,	1N60	DX-0161	DDAY 001004
D-43	Diode,	1S2075K	DX-1118	DDAY 063001
D-44	Diode,	1S2075K	DX-1118	DDAY 063001
D-45	Diode,	1N4003	DX-0207	DDAY 133001
D-46	Diode, Varistor,	MV-1Y	DX-0750	DDFY 020001
D-47	Diode, Varistor,	MV-13YH	DX-1275	DDFY 021001
D-48	Diode,	1S2075K	DX-1118	DDAY 063001
D-49	Diode,	1S2075K	DX-1118	DDAY 063001
D-60	Diode, Zener,	RD-20E-B1 20V	DX-1276	DDAY 086012
D-62	Diode,	1S2075K	DX-1118	DDAY 063001
D-65	Diode,	1S2075K	DX-1118	DDAY 063001
D-68	Diode,	1S2075K	DX-1118	DDAY 063001
D-70	Diode,	1S2075K	DX-1118	DDAY 063001
D-71	Diode,	1N4003	DX-0207	DDAY 133001
D-73	Diode,	1N60	DX-0161	DDAY 001004
D-74	Diode,	1S2075K	DX-1118	DDAY 063001
D-75	Diode, Zener,	XZ-051 5V		DDAY 020004
D-401	Diode, LED,	UR-202 Channel Display	DX-1274	DDAY 113001
D-410	Diode, LED,	TLR-124 AM indicator	DX-1273	DDAY 100001
D-411	Diode, LED,	TLR-124 USB indicator	DX-1273	DDAY 100001
D-412	Diode, LED,	TLR-124 LSB indicator	DX-1273	DDAY 100001
D-413	Diode, LED,	TLR-124 Mod. indicator	DX-1273	DDAY 100001
FET				
FET-1	FET,	2SK19-BL	2SK19-BL	DDCY 001002
INTEGRATED CIRCUITS				
IC-1	IC,	UHIC-070	MX-3918	DDEY 133001

REF. NO.	DESCRIPTION			RS. PART NO.	MFRS PART NO.
IC-2	IC,	MB 8734		MX-3917	DDEY 173001
IC-3	IC,	AN612		MX-3916	DDEY 130001
IC-4	IC,	TA7222P		MX-3618	DDEY 146001
IC-5	IC,	MB3756		MX-3920	DDEY 131001
IC-6	IC,	SO42P		MX-3919	DDEY 132001
COILS					
L-1	Coil,	LA-038	7.8 MHz	CA-3414	LLAY 038001
L-2	Coil,	LA-179	7.8 MHz	CA-3751	LLAY 179001
L-3	Coil,	LA-255	7.8 MHz	CA-5089	LLAY 255001
L-4	Coil,	LA-263	7.8 MHz	CA-5081	LLAY 263001
L-5	Coil,	LA-262	7.8 MHz	CA-5082	LLAY 262001
L-6	Coil,	LA-257	7.8 MHz	CA-5087	LLAY 257001
L-7	Coil,	LA-258	7.8 MHz	CA-5086	LLAY 258001
L-8	Coil,	LA-259	27 MHz	CA-5085	LLAY 259001
L-9	Coil,	LA-260	27 MHz	CA-5084	LLAY 260001
L-10	Coil,	LA-261	27 MHz	CA-5083	LLAY 261001
L-11	Inductor, Molded	LZ-012	470 μ H	C-0787	LLZY 012004
L-12	Inductor, Molded	LZ-012	100 μ H	C-0786	LLZY 012001
L-13	Coil,	LA-216	35 MHz	CA-5095	LLAY 216001
L-14	Coil,	LA-195	34.9 MHz	CA-3750	LLAY 195001
L-15	Inductor, Molded	LZ-012	470 μ H	C-0787	LLZY 012004
L-16	Inductor, Molded	LZ-012	470 μ H	C-0787	LLZY 012004
L-17	Coil,	LA-217	10.7 MHz	CA-5094	LLAY 217001
L-18	Coil,	LA-256	33 MHz	CA-5088	LLAY 256001
L-19	Coil,	LA-217	10.7 MHz	CA-5094	LLAY 217001
L-20	Coil,	LA-218	10.7 MHz	CA-5093	LLAY 218001
L-21	Inductor, Molded	LZ-012	470 μ H	C-0787	LLZY 012004
L-22	Inductor, Molded	LZ-012	470 μ H	C-0787	LLZY 012004
L-23	Inductor, Molded	LZ-012	470 μ H	C-0787	LLZY 012004
L-24	Inductor, Molded	LZ-012	470 μ H	C-0787	LLZY 012004
L-25	Inductor, Molded	LZ-012	100 μ H	C-0786	LLZY 012001
L-26	Coil,	LA-219	7.8 MHz	CA-5092	LLAY 219001
L-27	Coil,	LA-160	34.9 MHz	CA-5076	LLAY 160001
L-28	Coil,	LA-220	27 MHz	CA-5091	LLAY 220001
L-29	Coil,	LA-254	27 MHz	CA-5090	LLAY 254001
L-30	Coil,	LD-096		CA-5080	LLDY 096001
L-31	Coil,	LD-087	$Z(\Omega) = 43$	CA-3838	LLDY 087001
L-32	Coil,	LD-101	$Z(\Omega) = 35$	CA-5078	LLDY 101001
L-33	Coil,	LD-098	0.89 μ H	CA-5079	LLDY 098001
L-34	Coil,	LD-087	$Z(\Omega) = 43$	CA-3838	LLDY 087001
L-35	Coil,	LD-098	0.89 μ H	CA-5079	LLDY 098001
L-36	Coil,	LC-019	0.37 μ H	CA-3639	LLCY 109001
L-37	Coil,	LE-051	0.4 μ H	CA-3760	LLEY 051001
L-38	Coil,	LE-051	0.4 μ H	CA-3760	LLEY 051001
L-39	Coil,	LC-019	0.37 μ H	CA-3639	LLCY 019001
L-50	Coil,	LD-077	$Z(\Omega) = 40$	CA-3754	LLDY 077001
L-51	Coil,	LD-077	$Z(\Omega) = 40$	CA-3754	LLDY 077001
L-52	Coil,	LD-077	$Z(\Omega) = 40$	CA-3754	LLDY 077001
L-401	Coil,	LD-013	7.3 μ H	CA-3756	LLDY 013001
L-402	Coil,	LD-013	7.3 μ H	CA-3756	LLDY 013001
L-403	Coil,	LD-089	$Z(\Omega) = 85$	CA-3878	LLDY 089001
L-404	Coil,	LD-077	$Z(\Omega) = 40$	CA-3754	LLDY 077001
RESISTORS					
			Tolerance Code	J = 5%	
				K = 10%	
R-1	Carbon Film Resistor	18K ohm	1/8 W	J	RUBZ 181834

REF. NO.	DESCRIPTION	RS. PART NO.	MFRS PART NO.
R-2	Carbon Film Resistor 3.3K ohm 1/8W J		RUBZ 183324
R-3	Carbon Film Resistor 470 ohm 1/8W J		RUBZ 184714
R-4	Carbon Film Resistor 220 ohm 1/8W J		RUBZ 182214
R-5	Carbon Film Resistor 47K ohm 1/8W J		RUBZ 184734
R-6	Carbon Film Resistor 2.7K ohm 1/8W J		RUBZ 182724
R-7	Carbon Film Resistor 330 ohm 1/8W J		RUBZ 183314
R-8	Carbon Film Resistor 68 ohm 1/8W J		RUBZ 186804
R-9	Carbon Film Resistor 100K ohm 1/8W J		RPBZ 181044
R-10	Carbon Film Resistor 470K ohm 1/8W J		RUBZ 184744
R-11	Carbon Film Resistor 10K ohm 1/8W J		RUBZ 181034
R-12	Carbon Film Resistor 10K ohm 1/8W J		RUBZ 181034
R-13	Carbon Film Resistor 10K ohm 1/8W J		RUBZ 181034
R-14	Carbon Film Resistor 330 ohm 1/8W J		RUBZ 183314
R-15	Carbon Film Resistor 10K ohm 1/8W J		RUBZ 181034
R-16	Carbon Film Resistor 3.3K ohm 1/8W J		RUBZ 183324
R-17	Carbon Film Resistor 1.8K ohm 1/8W J		RPBZ 181824
R-18	Carbon Film Resistor 3.3K ohm 1/8W J		RUBZ 183324
R-19	Carbon Film Resistor 470 ohm 1/8W J		RPBZ 184714
R-20	Carbon Film Resistor 4.7K ohm 1/8W J		RUBZ 184724
R-21	Carbon Film Resistor 68 ohm 1/8W J		RUBZ 186804
R-22	Carbon Film Resistor 470K ohm 1/8W J		RUBZ 184744
R-23	Carbon Film Resistor 100 ohm 1/8W J		RUBZ 181014
R-24	Carbon Film Resistor 10K ohm 1/8W J		RUBZ 181034
R-25	Carbon Film Resistor 3.3K ohm 1/8W J		RUBZ 183324
R-26	Carbon Film Resistor 680 ohm 1/8W J		RUBZ 186814
R-27	Carbon Film Resistor 47K ohm 1/8W J		RPBZ 184734
R-28	Carbon Film Resistor 47K ohm 1/8W J		RUBZ 184734
R-29	Carbon Film Resistor 10K ohm 1/8W J		RUBZ 181034
R-30	Carbon Film Resistor 1K ohm 1/8W J		RUBZ 181024
R-31	Carbon Film Resistor 3.3K ohm 1/8W J		RUBZ 183324
R-32	Carbon Film Resistor 1K ohm 1/8W J		RUBZ 181024
R-33	Carbon Film Resistor 1K ohm 1/8W J		RPBZ 181024
R-34	Carbon Film Resistor 47K ohm 1/8W J		RUBZ 184734
R-35	Carbon Film Resistor 1K ohm 1/8W J		RUBZ 181024
R-36	Carbon Film Resistor 2.2K ohm 1/8W J		RUBZ 182224
R-37	Carbon Film Resistor 4.7K ohm 1/8W J		RUBZ 184724
R-38	Carbon Film Resistor 3.9K ohm 1/8W J		RUBZ 183924
R-39	Carbon Film Resistor 1K ohm 1/8W J		RUBZ 181024
R-40	Carbon Film Resistor 10K ohm 1/8W J		RUBZ 181034
R-41	Carbon Film Resistor 180K ohm 1/8W J		RUBZ 181844
R-42	Carbon Film Resistor 100 ohm 1/8W J		RUBZ 181014
R-43	Carbon Film Resistor 100 ohm 1/8W J		RUBZ 181014
R-44	Carbon Film Resistor 10K ohm 1/8W J		RUBZ 181034
R-45	Carbon Film Resistor 180K ohm 1/8W J		RUBZ 181844
R-46	Carbon Film Resistor 100 ohm 1/8W J		RUBZ 181014
R-47	Carbon Film Resistor 1.5K ohm 1/8W J		RPBZ 181524
R-48	Carbon Film Resistor 1.5K ohm 1/8W J		RUBZ 181524
R-49	Carbon Film Resistor 1.5K ohm 1/8W J		RPBZ 181524
R-50	Carbon Film Resistor 3.3K ohm 1/8W J		RUBZ 183324
R-52	Carbon Film Resistor 10K ohm 1/8W J		RPBZ 181034
R-53	Carbon Film Resistor 220 ohm 1/8W J		RUBZ 182214
R-54	Carbon Film Resistor 470 ohm 1/8W J		RUBZ 184714
R-55	Carbon Film Resistor 3.3 ohm 1/8W J		RUBZ 183394
R-56	Carbon Film Resistor 220 ohm 1/8W J		RUBZ 182214
R-57	Carbon Film Resistor 10K ohm 1/8W J		RPBZ 181034
R-58	Carbon Film Resistor 3.3K ohm 1/8W J		RUBZ 183324
R-59	Carbon Film Resistor 47K ohm 1/8W J		RUBZ 184734
R-60	Carbon Film Resistor 1.5K ohm 1/8W J		RUBZ 181524

REF. NO.	DESCRIPTION	RS. PART NO.	MFRS PART NO.
R-61	Carbon Film Resistor 150 ohm 1/8W J		RUBZ 181514
R-62	Carbon Film Resistor 68 ohm 1/8W J		RUBZ 186804
R-63	Carbon Film Resistor 100K ohm 1/8W J		RUBZ 181044
R-64	Carbon Film Resistor 47K ohm 1/8W J		RUBZ 184734
R-65	Carbon Film Resistor 100K ohm 1/8W J		RUBZ 181044
R-66	Carbon Film Resistor 47K ohm 1/8W J		RUBZ 184734
R-67	Carbon Film Resistor 470K ohm 1/8W J		RPBZ 184744
R-68	Carbon Film Resistor 1K ohm 1/8W J		RUBZ 181024
R-70	Carbon Film Resistor 1.5K ohm 1/8W J		RPBZ 181524
R-71	Carbon Film Resistor 1.5K ohm 1/8W J		RUBZ 181524
R-72	Carbon Film Resistor 2.7K ohm 1/8W J		RPBZ 182724
R-73	Carbon Film Resistor 33K ohm 1/8W J		RUBZ 183334
R-74	Carbon Film Resistor 12K ohm 1/8W J		RUBZ 181234
R-75	Carbon Film Resistor 33K ohm 1/8W J		RUBZ 183334
R-76	Carbon Film Resistor 6.8K ohm 1/8W J		RUBZ 186824
R-77	Carbon Film Resistor 2.2K ohm 1/8W J		RUBZ 182224
R-78	Carbon Film Resistor 2.2K ohm 1/8W J		RUBZ 182224
R-79	Carbon Film Resistor 2.2K ohm 1/8W J		RUBZ 182224
R-80	Carbon Film Resistor 1K ohm 1/8W J		RUBZ 181024
R-81	Carbon Film Resistor 100 ohm 1/8W J		RPBZ 181014
R-83	Carbon Film Resistor 100 ohm 1/8W J		RUBZ 181014
R-84	Carbon Film Resistor 270K ohm 1/8W J		RUBZ 182744
R-85	Carbon Film Resistor 560 ohm 1/8W J		RUBZ 185614
R-86	Carbon Film Resistor 10K ohm 1/8W J		RPBZ 181034
R-87	Carbon Film Resistor 56K ohm 1/8W J		RUBZ 185634
R-88	Carbon Film Resistor 1K ohm 1/8W J		RUBZ 181024
R-89	Carbon Film Resistor 3.3K ohm 1/8W J		RUBZ 183324
R-90	Carbon Film Resistor 15K ohm 1/8W J		RUBZ 181534
R-91	Carbon Film Resistor 680 ohm 1/8W J		RUBZ 186814
R-92	Carbon Film Resistor 39K ohm 1/8W J		RUBZ 183934
R-93	Carbon Film Resistor 390 ohm 1/8W J		RUBZ 183914
R-95	Carbon Film Resistor 68K ohm 1/8W J		RUBZ 186834
R-96	Carbon Film Resistor 100K ohm 1/8W J		RUBZ 181044
R-97	Carbon Film Resistor 3.3K ohm 1/8W J		RUBZ 183324
R-98	Carbon Film Resistor 3.3K ohm 1/8W J		RUBZ 183324
R-99	Carbon Film Resistor 4.7K ohm 1/8W J		RUBZ 184724
R-100	Carbon Film Resistor 33K ohm 1/8W J		RUBZ 183334
R-101	Carbon Film Resistor 2.2M ohm 1/8W J		RPBZ 182254
R-102	Carbon Film Resistor 15K ohm 1/8W J		RUBZ 181534
R-103	Carbon Film Resistor 680K ohm 1/8W J		RUBZ 186844
R-104	Carbon Film Resistor 10K ohm 1/8W J		RUBZ 181034
R-105	Carbon Film Resistor 10K ohm 1/8W J		RUBZ 181034
R-106	Carbon Film Resistor 220 ohm 1/8W J		RUBZ 182214
R-107	Carbon Film Resistor 1K ohm 1/8W J		RUBZ 181024
R-108	Carbon Film Resistor 22K ohm 1/8W J		RUBZ 182234
R-109	Carbon Film Resistor 10K ohm 1/8W J		RUBZ 181034
R-110	Carbon Film Resistor 2.2K ohm 1/8W J		RUBZ 182224
R-111	Carbon Film Resistor 4.7K ohm 1/8W J		RUBZ 184724
R-112	Carbon Film Resistor 100 ohm 1W K		RSJZ 101015
R-113	Carbon Film Resistor 1K ohm 1/8W J		RPBZ 181024
R-114	Carbon Film Resistor 1K ohm 1/8W J		RUBZ 181024
R-115	Carbon Film Resistor 22K ohm 1/8W J		RUBZ 182234
R-116	Carbon Film Resistor 180K ohm 1/8W J		RUBZ 181844
R-117	Carbon Film Resistor 3.3K ohm 1/8W J		RUBZ 183324
R-118	Carbon Film Resistor 100 ohm 1/8W J		RUBZ 181014
R-119	Carbon Film Resistor 68 ohm 1/8W J		RUBZ 186804
R-120	Carbon Film Resistor 3.3K ohm 1/8W J		RUBZ 183324
R-121	Carbon Film Resistor 1K ohm 1/8W J		RUBZ 181024

REF. NO.	DESCRIPTION	RS. PART NO.	MFRS PART NO.
R-122	Carbon Film Resistor 4.7K ohm 1/8W J		RPBZ 184724
R-123	Carbon Film Resistor 4.7K ohm 1/8W J		RUBZ 184724
R-124	Carbon Film Resistor 3.3K ohm 1/8W J		RUBZ 183324
R-125	Carbon Film Resistor 1.5K ohm 1/8W J		RUBZ 181524
R-126	Carbon Film Resistor 1K ohm 1/8W J		RUBZ 181024
R-127	Carbon Film Resistor 100 ohm 1/8W J		RUBZ 181014
R-128	Carbon Film Resistor 1K ohm 1/8W J		RUBZ 181024
R-129	Carbon Film Resistor 220 ohm 1/8W J		RUBZ 182214
R-130	Carbon Film Resistor 10K ohm 1/8W J		RUBZ 181034
R-131	Carbon Film Resistor 2.2K ohm 1/8W J		RUBZ 182224
R-132	Carbon Film Resistor 1K ohm 1/8W J		RUBZ 181024
R-133	Carbon Film Resistor 10K ohm 1/8W J		RUBZ 181034
R-134	Carbon Film Resistor 10K ohm 1/8W J		RUBZ 181034
R-135	Carbon Film Resistor 1.8K ohm 1/8W J		RUBZ 181024
R-136	Carbon Film Resistor 5.6K ohm 1/8W J		RUBZ 185624
R-137	Carbon Film Resistor 10K ohm 1/8W J		RUBZ 181034
R-138	Carbon Film Resistor 1 ohm 1/8W J		RUBZ 181094
R-140	Carbon Film Resistor 10K ohm 1/8W J		RUBZ 181034
R-141	Carbon Film Resistor 8.2K ohm 1/8W J		RUBZ 188224
R-142	Carbon Film Resistor 18K ohm 1/8W J		RUBZ 181834
R-143	Carbon Film Resistor 10K ohm 1/8W J		RUBZ 181034
R-144	Carbon Film Resistor 1K ohm 1/8W J		RUBZ 181024
R-145	Carbon Film Resistor 1K ohm 1/8W J		RUBZ 181024
R-146	Carbon Film Resistor 1.5K ohm 1/8W J		RPBZ 181524
R-147	Carbon Film Resistor 22K ohm 1/8W J		RUBZ 182234
R-148	Carbon Film Resistor 10K ohm 1/2W J		RPBZ 121034
R-149	Carbon Film Resistor 100 ohm 1/8W J		RUBZ 181014
R-150	Carbon Film Resistor 270 ohm 1/4W J		RPBZ 182714
R-151	Carbon Film Resistor 330 ohm 1/8W J		RUBZ 183314
R-152	Carbon Film Resistor 220 ohm 1/8W J		RUBZ 182214
R-153	Carbon Film Resistor 12 ohm 1/8W J		RUBZ 181204
R-154	Carbon Film Resistor 1.5K ohm 1/8W J		RUBZ 181524
R-155	Carbon Film Resistor 330 ohm 1/8W J		RUBZ 183314
R-156	Carbon Film Resistor 100 ohm 1/8W J		RUBZ 181014
R-157	Carbon Film Resistor 100 ohm 1/8W J		RPBZ 181014
R-158	Carbon Film Resistor 100 ohm 1/8W J		RUBZ 181014
R-159	Carbon Film Resistor 100 ohm 1/8W J		RUBZ 181014
R-160	Carbon Film Resistor 1K ohm 1/8W J		RUBZ 181024
R-162	Carbon Film Resistor 47 ohm 1/8W J		RUBZ 184704
R-163	Carbon Film Resistor 10 ohm 1/8W J		RUBZ 181004
R-170	Carbon Film Resistor 330 ohm 1/8W J		RUBZ 183314
R-171	Carbon Film Resistor 680 ohm 1/8W J		RUBZ 186814
R-172	Carbon Film Resistor 220K ohm 1/8W J		RPBZ 182244
R-175	Carbon Film Resistor 22K ohm 1/8W J		RUBZ 182234
R-176	Carbon Film Resistor 560 ohm 1/8W J		RUBZ 185614
R-177	Carbon Film Resistor 680K ohm 1/8W J		RUBZ 186844
R-178	Carbon Film Resistor 220K ohm 1/8W J		RUBZ 182244
R-179	Carbon Film Resistor 330 ohm 1/8W J		RUBZ 183314
R-182	Carbon Film Resistor 330 ohm 1/8W J		RUBZ 183314
R-183	Carbon Film Resistor 1K ohm 1/8W J		RPBZ 181024
R-184	Carbon Film Resistor 150 ohm 1/8W J		RPBZ 181514
R-185	Metal Film Resistor 220 ohm 1W K		RSJZ 102215
R-186	Carbon Film Resistor 1K ohm 1/8W J		RUBZ 181024
R-188	Carbon Film Resistor 5.6K ohm 1/8W J		RPBZ 185624
R-189	Carbon Film Resistor 3.3K ohm 1/8W J		RUBZ 183324
R-192	Carbon Film Resistor 2.7K ohm 1/8W J		RUBZ 182724
R-193	Carbon Film Resistor 10K ohm 1/8W J		RPBZ 181034
R-194	Carbon Film Resistor 560 ohm 1/8W J		RUBZ 185614

REF. NO.	DESCRIPTION	RS. PART NO.	MFRS PART NO.
R-195	Metal Film Resistor 22 ohm 2W K		RSJZ 202205
R-196	Metal Film Resistor 2.2 ohm 1W K		RSJZ 102295
R-197	Carbon Film Resistor 47K ohm 1/8W J		RUBZ 184734
R-198	Carbon Film Resistor 100K ohm 1/8W J		RUBZ 181044
R-199	Carbon Film Resistor 3.9K ohm 1/8W J		RUBZ 183924
R-201	Carbon Film Resistor 3.3K ohm 1/8W J		RUBZ 183324
R-202	Carbon Film Resistor 10K ohm 1/8W J		RUBZ 181034
R-203	Carbon Film Resistor 6.8K ohm 1/8W J		RUBZ 181624
R-204	Carbon Film Resistor 560 ohm 1/8W J		RUBZ 185614
R-205	Carbon Film Resistor 220 ohm 1/8W J		RUBZ 182214
R-207	Carbon Film Resistor 680 ohm 1/8W J		RPBZ 186814
R-209	Carbon Film Resistor 56 ohm 1/2W J		RPBZ 125604
R-216	Carbon Film Resistor 2.2K ohm 1/8W J		RUBZ 182224
R-217	Carbon Film Resistor 270 ohm 1/8W J		RUBZ 182714
R-218	Carbon Film Resistor 1.5M ohm 1/8W J		RPBZ 181554
R-219	Carbon Film Resistor 6.8K ohm 1/8W J		RPBZ 186824
R-220	Carbon Film Resistor 4.7K ohm 1/8W J		RPBZ 184724
R-221	Carbon Film Resistor 1K ohm 1/8W J		RPBZ 181024
R-222	Carbon Film Resistor 1K ohm 1/8W J		RPBZ 181024
R-401	Carbon Film Resistor 680 ohm 1/8W J		RUBZ 186814
R-402	Carbon Film Resistor 680 ohm 1/8W J		RUBZ 186814
R-403	Carbon Film Resistor 330 ohm 1/4W J		RPBZ 143314
R-404	Carbon Film Resistor 680 ohm 1/8W J		RUBZ 186814
R-405	Carbon Film Resistor 680 ohm 1/8W J		RUBZ 186814
R-406	Carbon Film Resistor 680 ohm 1/8W J		RUBZ 186814
R-407	Carbon Film Resistor 680 ohm 1/8W J		RUBZ 186814
R-408	Carbon Film Resistor 680 ohm 1/8W J		RUBZ 186814
R-409	Carbon Film Resistor 680 ohm 1/8W J		RUBZ 186814
R-410	Carbon Film Resistor 680 ohm 1/8W J		RUBZ 186814
R-411	Carbon Film Resistor 680 ohm 1/8W J		RUBZ 186814
R-412	Carbon Film Resistor 680 ohm 1/8W J		RUBZ 186814
R-413	Carbon Film Resistor 680 ohm 1/8W J		RUBZ 186814
R-425	Carbon Film Resistor 10K ohm 1/8W J		RUBZ 181034
SWITCHES			
S-401	Rotary Switch, SR-208 Channel	S-1339	SSRY 208001
S-403	Rotary Switch, SR-234 Mode	S-1338	SSRY 234001
S-404	Slide Switch, SW-186 MON-CB-PA	S-2529	SSWY 186001
S-406	Slide Switch, SW-116 EXT-BOTH-INT	S-2530	SSWY 116001
TRANSFORMERS			
T-1	AF Choke Coil, TF-151	CB-2458	TTFY 151001
T-402	Output Power Transformer, TF-167	TD-0190	TTFY 167001
TRANSISTORS			
TR-1	Transistor 2SC710-C	2SC710-C	DDBY209001
TR-2	Transistor 2SC710-C	2SC710-C	DDBY209001
TR-3	Transistor 2SC1730-L	2SC1730-L	DDBY269001
TR-4	Transistor 2SC 711-E	2SC711-E	DDBY210002
TR-5	Transistor 2SC711-E	2SC711-E	DDBY210002
TR-6	Transistor 2SC710-C	2SC710-C	DDBY209001
TR-7	Transistor 2SA628-F	2SA628-F	DDBY019001
TR-8	Transistor 2SC1730-L	2SC1730-L	DDBY269001
TR-9	Transistor 2SC1674-L	2SC1674-L	DDBY295002
TR-10	Transistor 2SC710-C	2SC710-C	DDBY209001

REF. NO.	DESCRIPTION	RS. PART NO.	MFRS PART NO.
TR-11	Transistor 2SC711-E	2SC711-E	DDBY 210002
TR-12	Transistor 2SC710-C	2SC710-C	DDBY 209001
TR-13	Transistor 2SC711-E	2SC711-E	DDBY 210002
TR-14	Transistor 2SA628-F	2SA628-F	DDBY 019001
TR-15	Transistor 2SC711-E	2SC711-E	DDBY 210002
TR-16	Transistor 2SC1730-L	2SC1730-L	DDBY 269001
TR-17	Transistor 2SC763-C	2SC763-C	DDBY 216001
TR-18	Transistor 2SC763-C	2SC763-C	DDBY 216001
TR-19	Transistor 2SC710-C	2SC710-C	DDBY 209001
TR-20	Transistor 2SC711-E	2SC711-E	DDBY 210002
TR-21	Transistor 2SC710-C	2SC710-C	DDBY 209001
TR-22	Transistor 2SC710-C	2SC710-C	DDBY 209001
TR-23	Transistor 2SC710-C	2SC710-C	DDBY 209001
TR-24	Transistor 2SC710-C	2SC710-C	DDBY 209001
TR-25	Transistor 2SC710-C	2SC710-C	DDBY 209001
TR-26	Transistor 2SC496-O	2SC496-O	DDBY 246001
TR-27	Transistor 2SC711-E	2SC711-E	DDBY 210002
TR-28	Transistor 2SC945A-Q	2SC945A-Q	DDBY 224003
TR-29	Transistor 2SC1312-F	2SC1312-F	DDBY 317001
TR-30	Transistor 2SA628-F	2SA628-F	DDBY 019001
TR-31	Transistor 2SA628-F	2SA628-F	DDBY 019001
TR-32	Transistor 2SC711-E	2SC711-E	DDBY 210002
TR-33	Transistor 2SC711-E	2SC711-E	DDBY 210002
TR-34	Transistor 2SC1419-C	2SC1419-C	DDBY 278002
TR-35	Transistor 2SC711-E	2SC711-E	DDBY 210002
TR-36	Transistor 2SC1312-F	2SC1312-F	DDBY 317001
TR-37	Transistor 2SC711-E	2SC711-E	DDBY 210002
TR-38	Transistor 2SC1973	2SC1973	DDBY 272001
TR-39	Transistor 2SC1306	2SC1306	DDBY 230001
TR-40	Transistor 2SC496-O	2SC496-O	DDBY 246001
TR-41	Transistor 2SC1969-B	2SC1969-B	DDBY 307001
TR-42	Transistor 2SC710-C	2SC710-C	DDBY 209001
TR-45	Transistor 2SA628-F	2SA628-F	DDBY 019001
TR-47	Transistor 2SC711-E	2SC711-E	DDBY 210002
TR-48	Transistor 2SC711-E	2SC711-E	DDBY 210002
TR-49	Transistor 2SC711-E	2SC711-E	DDBY 210002

REF. NO.	DESCRIPTION	RS. PART NO.	MFRS PART NO.
VARIABLE RESISTORS			
VR-1	Semi-Fixed Resistor, RV-182 10K ohm B	P-6556	RRVY182005
VR-3	Semi-Fixed Resistor, RV-182 3K ohm B	P-6558	RRVY182012
VR-5	Semi-Fixed Resistor, RV-182 10K ohm B	P-6556	RRVY182005
VR-6	Semi-Fixed Resistor, RV-182 5K ohm B	P-6557	RRVY182004
VR-7	Semi-Fixed Resistor, RV-182 10K ohm B	P-6556	RRVY182005
VR-8	Semi-Fixed Resistor, RV-182 500 ohm B	P-6560	RRVY182001
VR-9	Semi-Fixed Resistor, RV-182 5K ohm B	P-6557	RRVY182004
VR-10	Semi-Fixed Resistor, RV-182 100K ohm B	P-6555	RRVY182008
VR-12	Semi-Fixed Resistor, RV-182 30K ohm B		RRVY182013
VR-401,407	Variable Resistor, 2-shaft RV-411, 100K ohm B Squelch 1K ohm B Dimmer	P-1979	RRVY411001
VR-402	Variable Resistor, RV-203 20K ohm B Clarifier	P-1980	RRVY203001
VR-403 & S402	Variable Resistor, RV-374 10K ohm A Volume	P-1978	RRVY374001
VR-404 & S405	Variable Resistor, RV-412 10K ohm B RF Gain	P-0884	RRVY412001
CRYSTALS			
X-1	Xtal, QX-077 10.24 MHz	MX-2391	QQXY077001
X-2	Xtal, QX-084 7.8025 MHz	MX-2393	QQXY084001
X-3	Xtal, QX-083 7.7975 MHz	MX-2392	QQXY083001
X-4	Xtal, QX-086 11.3258 MHz	MX-2394	QQXY086001

REF. NO.	DESCRIPTION	RS PART NO.	MFRS PART NO.
MISCELLANEOUS			
	P.C. Board Ass'y (MAIN)	X-8159	508F-PC622
	P.C. Board Ass'y (CH LED)	X-8158	508F-PC381
	P.C. Board Ass'y (CH SW)	X-8157	508F-PC616
	P.C. Board Ass'y (MIC JACK)	X-8156	508F-PC465
	P.C. Board Ass'y (SLIDE SW)	X-8155	508F-PC568
SP-401	Speaker	SP-050	S-4826
M-401	Meter	MT-193	ASPY 050001
	Microphone	MK-115	M-0427
J-403	Socket, 3F	JK-052, DC, Power	M-2303
J-405	M Type Connector	JK-035, Antenna	J-0819
	Speaker Cord,	JK-082	J-6421
J-401	Jack	JK-089, PA SP	W-2368
J-402	Jack	JK-089, EXT SP	J-0897
J-404	Jack	JK-125, Microphone	J-0897
TP-7	Check Terminal	TP-027	J-1042
TP-8	Check Terminal	TP-027	J-4502
F-401	Fuse, 4A	FS-014	J-4502
	Insulation Sheet	YD-033, TR-34	JJPY 027001
	Insulation Sheet	YD-039, IC-4	JJPY 027001
	Insulation Sheet	YD-040, IC-5	HF-0076
	Insulation Sheet	YY-027, TR-39, TR-41	ZFSY 014003
	Insulation Bush.	YY-036, TR-34, TR-39, TR-41	ZYDY 033001
	Wire Clamper	YY-047	ZYDY 039001
FC-3	Flat Cable	WF-011	HB-7837
FC-1	Flat Cable	WF-005	HB-8688
FC-2	Flat Cable	WF-005	HB-8688
	DC Cord	W-070234	ZYDY 040001
FT-1	Crystal Filter	FL-065 7.8 MHz	HB-6156
FT-2	Crystal Filter	FL-046 7.8 MHz	HB-6158
			ZYYY 027001
			ZYYY 036001
			ZYYY 047001
			W-2357
			WWFY011105
			W-2358
			WWFY005174
			W-2359
			WWFY005102
			W-2360
			WZDZ 070234
			C-0996
			FFLY 065001
			C-0794
			FFLY 046001

21. MECHANICAL PARTS LIST

REF. NO.	DESCRIPTION	RS PART NO.	MFRS PART NO.
1	Chassis w/FCC plate ①⑨		MDBC 205978
2	Cover, Top	Z-4849	MDBP 208134
3	Cover, Bottom	Z-4850	MDBP 208135
4	Bracket for Mounting	MB-0231	MDBP 406058
5	Chassis, Front		MDBP 308131
6	Metal Strip, Earth	HB-8689	MDBP 405562
7	Microphone Manager	HB-8690	MDBP 402919
8	Panel, Front	Z-4851	MDMP 208130
9	Knob, Channel	K-2555	MDMP 404011
10	KNob, Concentric, Outer (Dimmer)	K-2557	MDMP 404151
11	Knob, Concentric, Inner (Squelch)	K-3521	MDMP 403072
12	Knobs (Volume, Clarifier, RF Gain, MODE)	K-2283	MDMP 401728
13	Holder, LED	HB-6165	MDMP 404790
14	Holder, LED	HB-6166	MDMP 403857
15	Holder, LED	HB-8691	MDMP 407400
16	Screw, Mounting	HD-1309	MDMC405736
17	Nameplate, Control	HB-8692	MDNP 408132
18	Nameplate, Brand	HB-8693	MDNP 408133
19	ID Plate, FCC, Part to chassis assembly ①	HB-8694	MDNP 408136
20	Cushion for Meter	HB-6174	MDZP 404015
21	Washer, Rubber	HD-8221	MDZP 400638
22	Optical Shielding Cloth	HB-7247	MDZP 404304
23	Screw, Pan Hd, Plastic, M3 x 6	HD-1181	MZSS 123006
24	Screw, Flat Hd, M3 x 8	HD-4021	MZSN 133008
25	Screw, Bind Hd, M2.6 x 4	HD-2042	MZSN 192604
26	Screw, Bind Hd, M2.6 x 6		MZSN 192606
27	Screw, Bind Hd, M2.6 x 10	HD-2048	MZSN 192610
28	Screw, Bind Hd, M3 x 6	HD-2055	MZSN 193006
29	Screw, Bind Hd, M3 x 8	HD-2057	MZSN 193008
30	Screw, Bind Hd, M3 x 5	HD-3025	MZSB 193005
31	Tapping Screw, Pan Hd, (Pointed) ZMC, 5 ϕ x 16	HD-3052	MZSZ 235016
32	Tapping Screw, Round Hd, ZMC, 3.5 ϕ x 8	HD-3043	MZSZ 293508
33	Tapping Screw, Flat Hd, ZMC, 2.5 ϕ x 6	HD-3010	MZSZ 272506
34	Tap Tight Screw, Bind Hd, ZMC, M3 x 8	HD-3028	MZSZ 343008
35	Nut, Hex, Ni, M2.6	HD-7002	MZSN 430026
36	Nut, Hex, M3	HD-7003	MZSN 430030
37	Nut, Flange, ZMC, M3	HD-7080	MZSZ 480030
38	Washer, Spring, 2.6 ϕ	HD-8016	MZSN 510026
39	Washer, Lock, ZMC, 3.5	HD-8042	MZSZ 530035
40	Washer, Star, ZMC, 5	HD-8249	MZSZ 540050
41	Terminal, Lug, Solder	HB-4089	MZTT 150003
42	Spring for Knob (Channel)	RB-5756	MZTT 200003
43	Spring for Knob (Dimmer)	RB-5855	MZTT 200002
44	Spring for Knob (Squelch)	RB-5868	MZTT 200001
45	Rivet, AL, ID Plate, 3.2 ϕ x 5 ℓ , Part to Chassis assembly ①	HB-6578	MZTT 213250
46	Selflock Inserter (Banc-lok)	HB-8695	MZTT 263020

RADIO SHACK  A DIVISION OF TANDY CORPORATION
U.S.A.: FORT WORTH, TEXAS 76102
CANADA: BARRIE, ONTARIO L4M 4W5

TANDY CORPORATION

AUSTRALIA

**280-316 VICTORIA ROAD
BYDALMERE, N.S.W. 2116**

BELGIUM

**PARC INDUSTRIEL DE NANINNE
5140 NANINNE**

U. K.

**BILSTON ROAD, WEDNESBURY
WEST MIDLANDS WS10 7JN**