

SCHEMATIC DIAGRAM

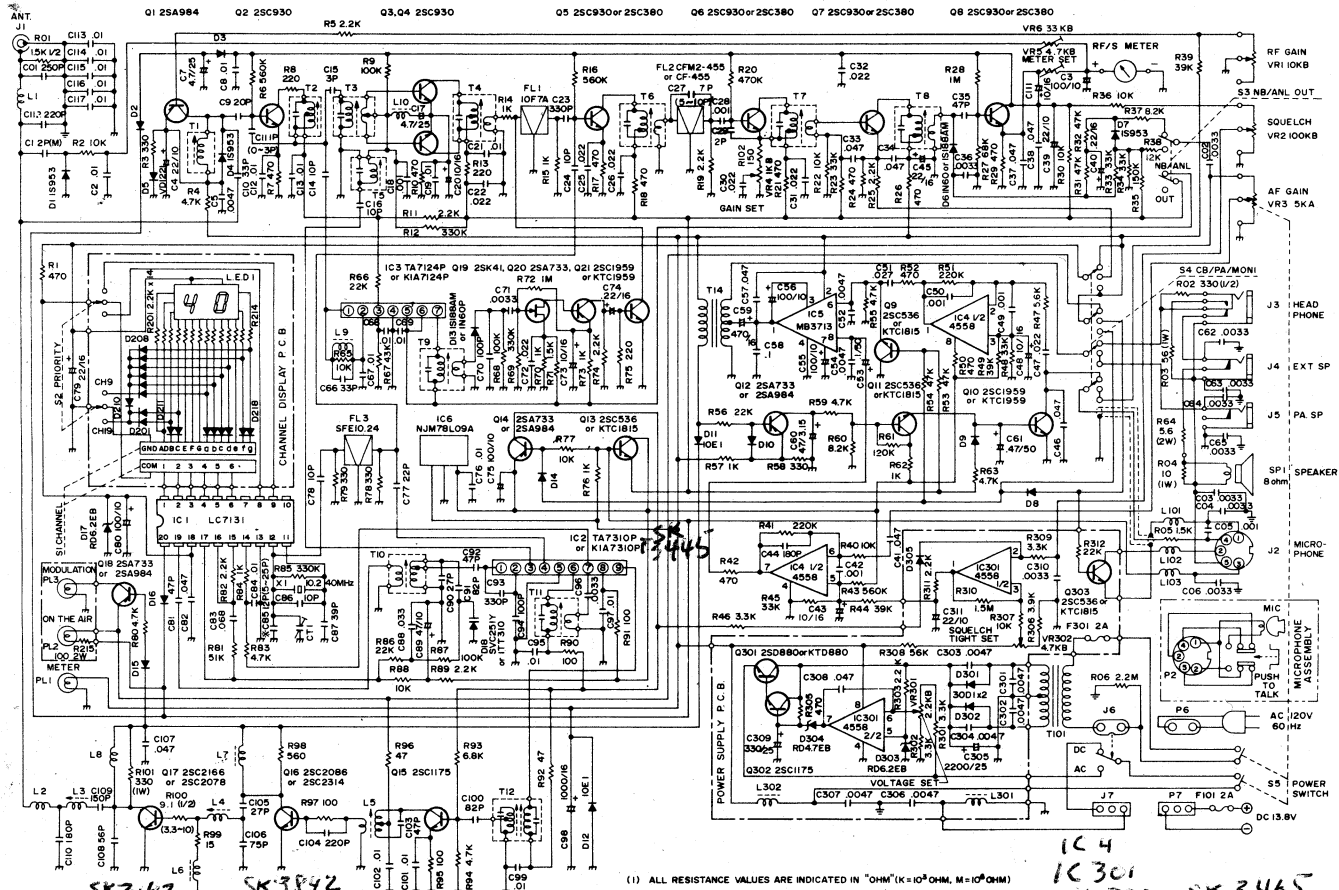

- (1) ALL RESISTANCE VALUES ARE INDICATED IN "OHM" (K=10³ OHM, M=10⁶ OHM)
- (2) ALL CAPACITANCE VALUES ARE INDICATED IN "µF" (P=10⁻⁹ µF)
- (3) NOT INDICATED DIODES ARE 1SS53.

IC 4
 IC 301
 4558D = SK3465