

SPECIFICATIONS

Circuit system	Receiving section Crystal controlled dual conversion superheterodyne with RF amplifier full variable squelch and noise limiter. Transmitting section Crystal controlled oscillation. collector modulation system.
Semi-conductor	16 Transistor plus 1 Transistor in squelch circuit. 1 Zener Diode 5 Diodes 1 Thermistor 1 Varistor
Frequency	27 MHz citizen band synthesized system 23 Channels
Modulation	AM - High Level
Operation	Push-to-talk system
Antenna	Telescopic, 10 section, 69"
Speaker-Microphone	2 $\frac{3}{4}$ " Dynamic speaker, 100 ohm
Controls	Channel selector switch, full variable squelch, OFF-ON volume control, battery saving switch.
External jack	External power jack, Charger jack, External speaker jack, External mic jack, External antenna jack.
Power source	15 volts DC
Cabinet	All metal with diecast chrome grille
Dimensions	10-3/8" High x 3-3/8" Wide x 2-3/8" Deep.
Weight	3-3/4 pounds.
Receiving section	Sensitivity 1 μ V at 10dB S/N Squelch sensitivity 1 μ V Nominal Intermediate frequency 1st 5.995MHz/6.015/6.025/6.035 2nd 455 KHz
Transmitting section	Audio output 0.5 watt Power input 5 watt Frequency tolerance \pm 0.005%
Accessories included	Leather case, carrying strap, two(2) dummy batteries and instruction booklet.

SERVICE INFORMATION

The technical information, diagrams, and charts provided in this manual are supplied for the use of a qualified holder of a first or second class radiotelephone license in servicing this transceiver. It is the users responsibility to see that this unit is operating at all times in accordance with the F.C.C. Citizens Radio Service regulations.

If you install or service your own transceiver, do not attempt to make any transmitter tuning adjustment. Transmitter adjustments are prohibited by the F.C.C. unless you hold a first or second class radiotelephone license or are in the presence of a person holding such a license. A Citizens Band or Amateur license is not sufficient.

MIDLAND ELECTRONICS COMPANY HEREBY
CERTIFIES THAT THIS UNIT HAS BEEN DESIGNED
AND MANUFACTURED IN ACCORDANCE WITH VOL. 6,
PART 95 OF THE CURRENT FCC RULES AND REGULATIONS
AS OF THE DATE OF MANUFACTURE.

DISASSEMBLY INSTRUCTIONS

To remove the back cover, loosen the two large slotted screws located on the bottom and back of the cabinet (Refer to (c) and (d), Figure 6).

To remove the front panel, loosen the set screws in the volume, squelch, and channel selector knobs and remove these knobs. Then remove two phillips head screws from each side of the cabinet. (Refer to (a) and (b), Figure 6)

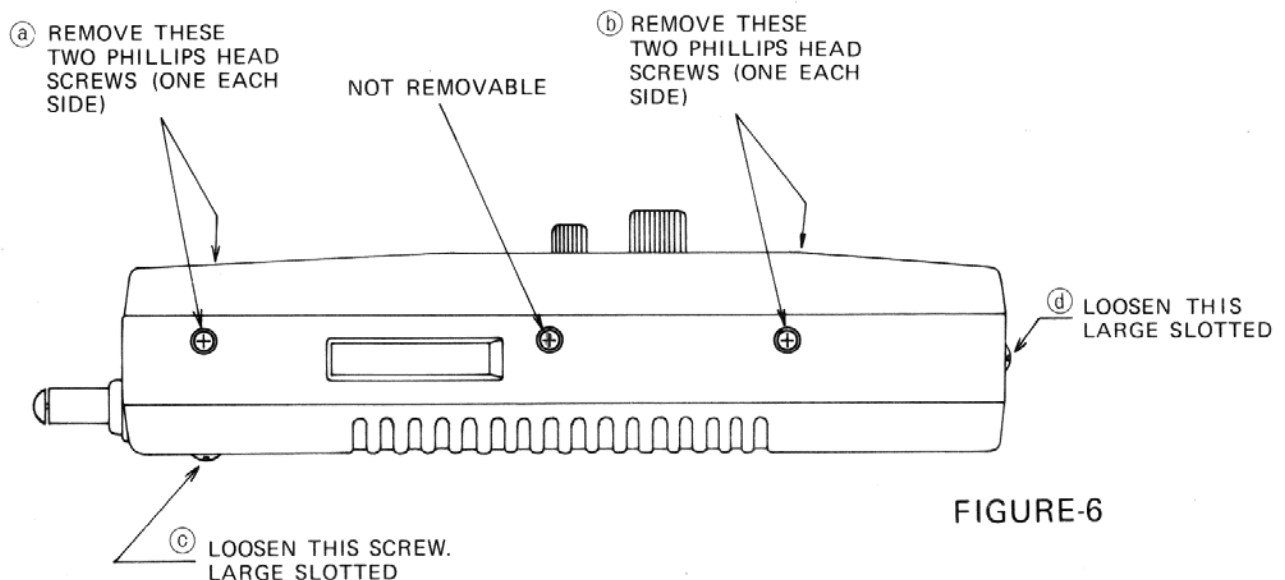

ADJUSTMENT GUIDE

Caution: The antenna must be fully extended, or a suitable load applied when transmitting or the output transistors may be damaged.

Transmitting section

1. Set the channel selector to channel 13.
2. Connect an RF power meter to the external antenna jack. (Antenna withdrawn).
3. Connect a suitable, metered, 15 volt power supply to the external power jack.
4. Press the push-to-talk switch and adjust the transmitting coil only, for maximum RF output. (Note current drain from power supply)
5. Disconnect the RF power meter and fully extend the antenna.
6. Press the push-to-talk switch and adjust the antenna loading coil for the same power supply current drain as obtained in step 4.

Receiving Section

1. Adjust a signal generator to 455 KHz with 30% modulation at 1 KHz.
Adjust the 4 transformers of the second IF stage for maximum indication on the front panel output meter.
2. Set the channel selector to channel 11. and using another transceiver or transmitter as a signal source, adjust the antenna coil, the RF coil, and the 2 transformers of the first IF stage for maximum indication on the output meter.

FREQUENCY SYNTHESIZER CRYSTAL COMBINATION LIST

(A) Group 6 pcs.

- a. :33.000 MHz
- b. :33.050 MHz
- c. :33.100 MHz
- d. :33.150 MHz
- e. :33.200 MHz
- f. :33.250 MHz

(B) Group 4 pcs.

(Transmitting)

- a' :6.035 MHz
- b' :6.025 MHz
- c' :6.015 MHz
- d' :5.995 MHz

(C) Group 4 pcs.

(Receiving)

- a'' :6.490 MHz
- b'' :6.480 MHz
- c'' :6.470 MHz
- d'' :6.450 MHz

<u>CHANNEL</u>	<u>FREQUENCY(MHz)</u>	<u>Combination (Transmit)</u>	<u>Combination (Receive)</u>
1.	26.965	a-a'	a-a''
2.	26.975	a-b'	a-b''
3.	26.985	a-c'	a-c''
4.	27.005	a-d'	a-d''
5.	27.015	b-a'	b-a''
6.	27.025	b-b'	b-b''
7.	27.035	b-c'	b-c''
8.	27.055	b-d'	b-d''
9.	27.065	c-a'	c-a''
10.	27.075	c-b'	c-b''
11.	27.085	c-c'	c-c''
12.	27.105	c-d'	c-d''
13.	27.115	d-a'	d-a''
14.	27.125	d-b'	d-b''
15.	27.135	d-c'	d-c''
16.	27.155	d-d'	d-d''
17.	27.165	e-a'	e-a''
18.	27.175	e-b'	e-b''
19.	27.185	e-c'	e-c''
20.	27.205	e-d'	e-d''
21.	27.215	f-a'	f-a''
22.	27.225	f-b'	f-b''
23.	27.255	f-d'	f-d''

SCHEMATIC DIAGRAM

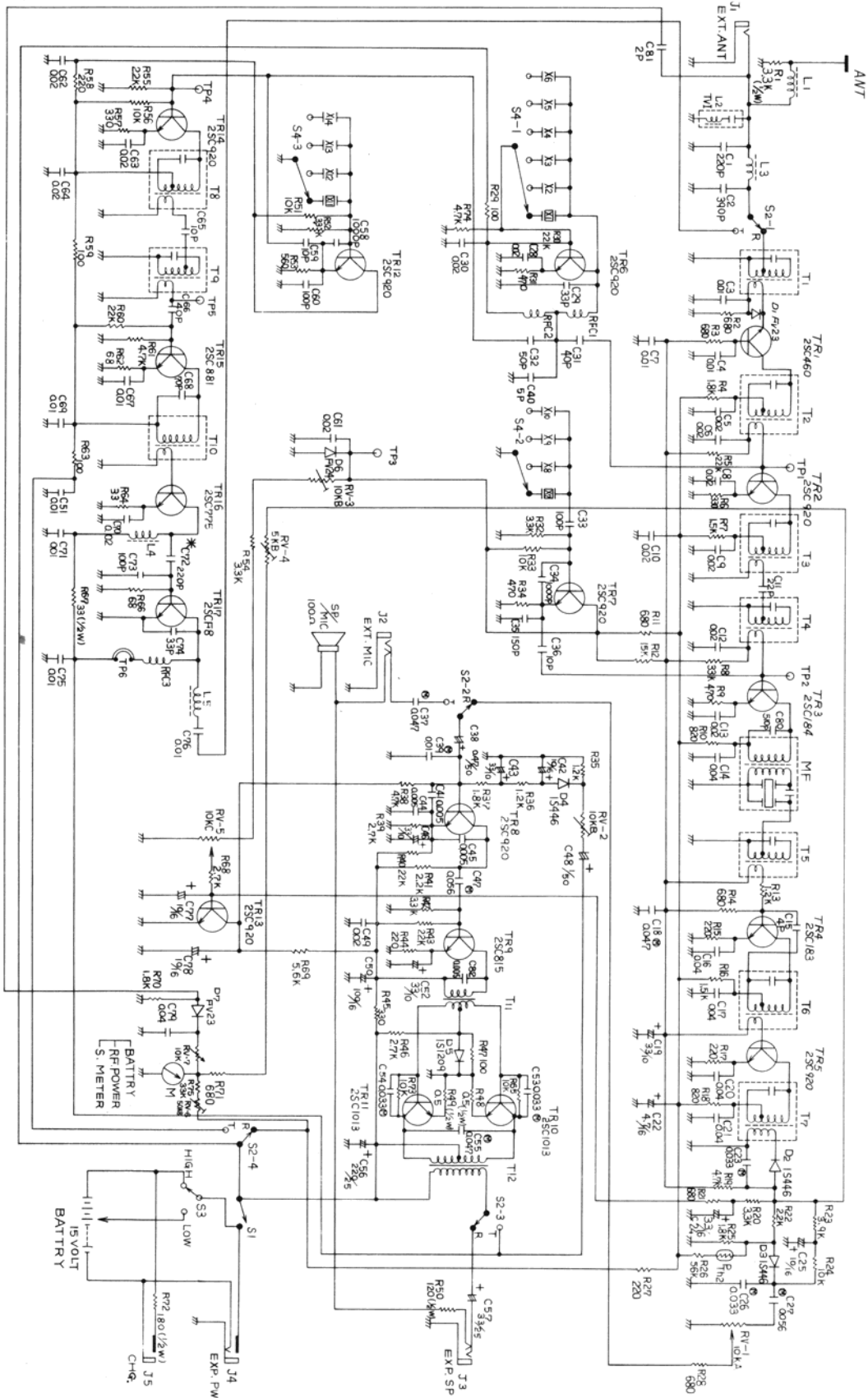

- S1 - POWER SWITCH WITH VOLUME CONTROL.
 S2-S4 - PUSH TO TALK SWITCH
 S3 - BATTERY SAVING SWITCH
 CRYSTAL - X - Y4
 X1 - 33.000MHZ, X2 - 33.050M, X3 - 33.100M, X4 - 33.150M, X5 - 33.200M, X6 - 33.250M,
 X7 - 6.490MHZ, X8 - 6.480M, X9 - 6.470M, X10 - 6.450M,
 X11 - 6.035MHZ, X12 - 6.025M, X13 - 6.015M, X14 - 5.995M.

* ADJUSTABLE
 POLYESTER FILM
 CAPACITOR

WARRANTY POLICY

Midland Electronics Company warrants each new Midland product to be free from defects in material and workmanship under normal use and service for a period of 90 days after delivery to the ultimate user and will replace or repair the product, at our option, at no charge should it become defective and which our examination shall disclose to be defective and under warranty.

This warranty shall not apply to any Midland product which has been subject to misuse, neglect, accident, incorrect wiring not of our own installation, or to use in violation of instructions furnished by us, nor extended to units which have been repaired or altered outside of our factory.

This warranty does not cover carrying cases, batteries, antennas, broken or cracked cabinets, or any other accessory used in connection with the product.

This warranty is in lieu of all other warranties expressed or implied and no representative or person is authorized to assume for us any other liability in connection with the sale of our products.

Sales receipt must accompany product to validate date of purchase.

MIDLAND ELECTRONICS COMPANY

1909 Vernon Street

North Kansas City, Missouri 64116

Copyright 1972 Midland Electronics Company
North Kansas City, Missouri 64116 U.S.A.
Made Exclusively for Midland Electronics Co. in Japan

Printed in Japan