

23 CHANNEL SSB/AM
FREQUENCY SYNTHESIZED
CB TRANSCEIVER

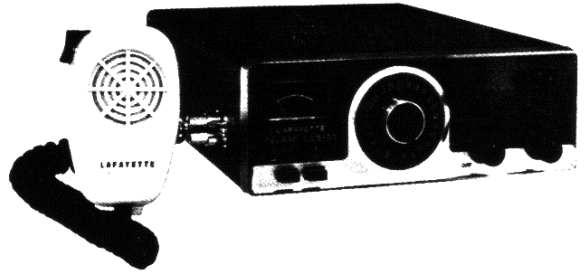

SERVICE MANUAL

Model TELSAT SSB-50

Stock No. 99-32666W



LAFAYETTE RADIO ELECTRONICS CORPORATION

CONTENTS

FOREWORD	1
DC POWER SUPPLY	1
Negative Ground Systems	1
Positive Ground Systems	1
ALIGNMENT PROCEDURE	2
1. SYNTHESIZER ALIGNMENT	2
A. Q1 and Q2 Oscillator Adjustment	2
B. Q3 Oscillator Adjustment	2
C. Q4 Oscillator Adjustment	2
D. Q6 and Q7 Oscillator Adjustment	3
2. TRANSMITTER ALIGNMENT	3
A. RF Power Output Adjustment	3
B. SSB Transmission Adjustment	3
[1] Driver [Q12] and Final [Q13] Stage Adjustment	3
[2] Carrier Balance Adjustment	3
[3] SSB Modulation Adjustment	3
C. RF Meter Adjustment	4
D. Range Boost Adjustment on AM Transmission	6
3. RECEIVER ADJUSTMENT	6
A. AM Reception Adjustment	6
[1] Second Local Oscillator [Q33] Adjustment	6
[2] RF and IF Alignment	6
B. SSB Reception Adjustment	6
[1] IF Alignment	6
[2] Sensitivity Check for SSB Reception	6
[3] AGC Alignment	7
[4] S-Meter Alignment	7
[5] Squelch Alignment	7
C. Noise Silencer Alignment	7
BLOCK DIAGRAM	8
INTERNAL ELECTRICAL PARTS LOCATION [PC BOARDS]	11
FRONT PANEL MECHANICAL PARTS LOCATION	14
INTERNAL MECHANICAL PARTS LOCATION [TOP VIEW]	14
REAR PANEL MECHANICAL PARTS LOCATION	15
INTERNAL MECHANICAL PARTS LOCATION [BOTTOM VIEW]	15
COMPLETE PARTS LIST	16
SCHEMATIC DIAGRAM	(Separate Sheet)
PARTS LOCATION	(Separate Sheet)

FOREWORD

This service manual has been carefully prepared to aid you in servicing the LAFAYETTE TELSAT SSB-50 GB Transceiver. It contains Voltage Data, Alignment Procedure, Mechanical and Electrical Parts Locations, Complete Parts List, Block Diagram and Schematic Diagram.

Before servicing this unit read TELSAT SSB-50 Installation and Operating Manual, as it will help you to understand the correct operation of the Transceiver's controls and their functions.

CAUTION: Only a qualified technician having enough knowledge and experience in the repair of solid state equipment should attempt to service this transceiver, or damage to the unit may result.

Please follow the procedures outlined -- do not attempt any short-cuts.

- * Do not use an ohmmeter to test transistors. In some instances the voltage across the test probes of an ohmmeter may exceed the base to emitter breakdown voltage. Therefore, do not use an ohmmeter for testing transistors unless you are certain of the transistor's capability.
- * Do not replace a defective output transistor, until you have determined the cause of its failure. To assume it was a defective transistor only may result in further damage not only to the replacement, but to other transistors in that channel.
- * When installing a power transistor, make sure that the bottom of its mounting flange, surface of the heat sink and the insulator between them are free of dust and dirt particles. Failure to observe this precaution will prevent proper heat transfer and may even puncture the insulator, causing a short circuit to ground. Also, for proper heat transfer, both sides of the insulator should be coated with silicone grease.
- * To prevent damage to the printed circuit boards and components, use the correct soldering iron; small diameter tip for single connection, large areas and special de-soldering tip for multiple connection component removal.

1. BLACK LEAD HERE FOR NEGATIVE GND VEHICLES
2. RED LEAD HERE FOR POSITIVE GND VEHICLES

DC POWER SUPPLY

WARNING: As supplied, the SSB-50 is wired to operate from a battery source of 12.6 volts DC, on negative ground systems. Connecting the unit to a positive ground vehicle without making the necessary internal wiring change will blow 1.5A primary fuse. Before making any power connections you must determine whether the vehicle has a negative or positive ground electrical system and follow the appropriate instructions below.

NEGATIVE GROUND SYSTEMS

Connect the fused power lead [RED] of the DC power cord to the positive or "hot" side of the electrical system. Points normally available for this purpose are the accessory post on the ignition switch, the voltage regulator side of the ammeter or the accessory side of the fuse block. The other lead [BLACK] should be connected to the metal fire-wall or any other point that is connected to the vehicle chassis.

POSITIVE GROUND SYSTEMS

Before using the SSB-50 for operation in vehicles with a positive ground electrical system, the following internal wiring change must be made.

1. Remove the four Phillips head screws [two on each side of the unit] fastening the uppermost chassis cover.

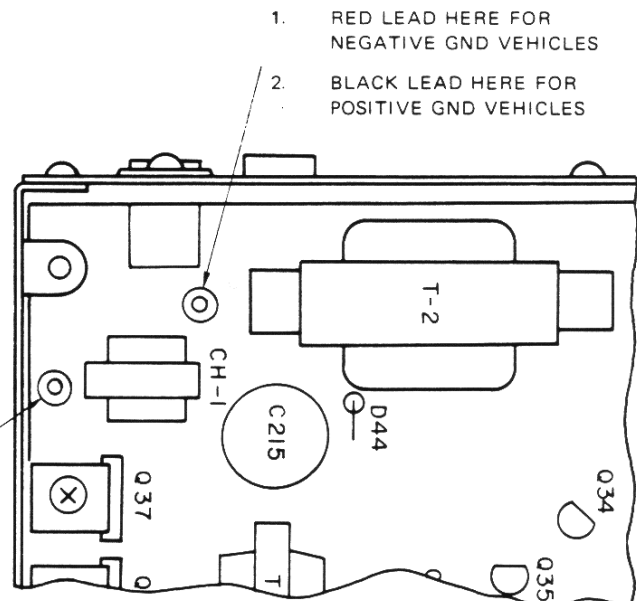

TELSAT SSB-50 INTERNAL VIEW

2. Remove the chassis cover
3. Refer to Internal View, which shows the location of the two leads [red and black] which must be interchanged for positive ground operation. Each lead is attached to its terminal by a push-on type lug. To remove, simply pull steadily on the lug. Interchange the two leads as indicated in the diagram and push each lug down over its assigned terminal.
4. Replace the chassis cover

Connect the DC power cord as follows: Connect the fused [red] lead the vehicle "hot" point or source [in the case of positive ground vehicles this is the negative battery side.] Connect the black lead to the vehicle chassis, or any other point that is connected to the chassis.

TELSAT SSB-50 TRANSCEIVER ALIGNMENT PROCEDURE

1. SYNTHESIZER ALIGNMENT

A. Q1 and Q2 Oscillator Adjustment

- [1] Set Channel Selector Switch to CH-13 position.
- [2] Set Mode Switch [AM/USB/LSB] to AM position.
- [3] Set NS/ANL Switch to ANL position.
- [4] Connect DC VTVM and Frequency Counter between [TP-26] and PC Board Ground.
- [5] Supply 13.8V DC through the power socket of the unit.
- [6] Rotate core of L1 and L2 for maximum reading on VTVM.

TABLE 1.
Crystal Frequencies for TELSAT SSB-50.

CHANNEL	TRIMMER CAPACITOR	READING ON FREQUENCY COUNTER
CH-1	TC-1	23.330MHZ ±0.1KHZ
CH-5	TC-2	23.380MHZ ±0.1KHZ
CH-9	TC-3	23.430MHZ ±0.1KHZ
CH-13	TC-4	23.480MHZ ±0.1KHZ
CH-17	TC-5	23.530MHZ ±0.1KHZ
CH-21	TC-6	23.580MHZ ±0.1KHZ
CH-1	TC-7	14.910MHZ ±0.1KHZ
CH-2	TC-8	14.920MHZ ±0.1KHZ
CH-3	TC-9	14.930MHZ ±0.1KHZ
CH-4	TC-10	14.950MHZ ±0.1KHZ
CH-1	TC-11	14.907MHZ ±0.1KHZ
CH-2	TC-12	14.917MHZ ±0.1KHZ
CH-3	TC-13	14.927MHZ ±0.1KHZ
CH-4	TC-14	14.947MHZ ±0.1KHZ

- [7] Rotate FINE TUNE control to the 12 o'clock position. Do not key microphone.
- [8] Rotate Trimmer Capacitor TC-4 until Frequency Counter indicates the proper frequency [see Table 1].
- [9] Set Channel Selector Switch to each of the following channels [CH-1, CH-5, CH-9, CH-17, CH-21], and adjust each frequency by rotating the appropriate Trimmer Capacitor until the Frequency Counter indicates the proper frequency [see Table 1].
- [10] Make sure that the Frequency Counter readings are approximately the same as the readings in Step 9.
- [11] Rotate the FINE TUNE control from the 12 o'clock position to the 4 o'clock position. The Frequency Counter reading should be +1.8 KHZ ±100Hz.
- [12] Rotate the FINE TUNE control from the 12 o'clock position to the 8 o'clock position. The Frequency Counter reading should be -1.7KHZ ±100Hz.

B. Q3 Oscillator Adjustment

- [1] Set Channel Selector Switch to CH-1 position.
- [2] Set MODE Switch to AM position.
- [3] Set NS/ANL Switch to ANL position.
- [4] Connect 50 ohm Dummy load to ANT Connector.
- [5] Connect DC VTVM and Frequency Counter between Q3 Emitter [TP-3] and PC Board Ground.
- [6] Depress Microphone PUSH-TO-TALK button.
- [7] Rotate core of L3 clockwise until the oscillating voltage indicates zero on VTVM. Then rotate the core of L3 counter clockwise, the VTVM reading will increase rapidly. Turn the core about 2 turns after reaching the maximum indication on VTVM.
- [8] Rotate Trimmer Capacitor TC-7 until Frequency Counter indicates from 14.910 MHz ± 200 Hz.
- [9] Set Channel Selector Switch to each of the following channels [CH-2, CH-3, CH-4], and adjust each Frequency by rotating Trimmer Capacitor TC-8 TC-9, TC-10 until the Frequency Counter indicates the proper frequency [see Table 1].

C. Q4 Oscillator Adjustment

- [1] Set Channel Selector Switch to CH-1 position.
- [2] Set MODE Switch to LSB position.
- [3] Set NS/ANL Switch to ANL position.
- [4] Connect Dummy Load [50 ohms] to ANT Connector.
- [5] Connect DC VTVM and Frequency Counter between Q4 Emitter [TP-4] and PC Board Ground.
- [6] Depress Microphone PUSH-TO-TALK button.

- [7] Turn down core of L4 until the oscillating voltage indicates zero on VTVM. Then rotate the core of L4 counterclockwise, the VTVM reading will increase rapidly. Turn the core about 2 turns further after reaching the maximum indication on VTVM.
- [8] Set Channel Selector Switch from CH-1 to CH-2, CH-3, CH-4 and adjust each frequency by rotating Trimmer Capacitors TC-11, TC-12, TC-13 and TC-14 until the Frequency Counter indicates the proper frequency [see Table 1].

D. Q6 and Q7 Oscillator Adjustment

- [1] Set MODE Switch to USB position.
- [2] Connect Frequency Counter high impedance input between Q8 Emitter [TP-8] and PC Board Ground.
- [3] Connect RF VTVM high impedance input between Q8 Emitter [TP-8] and PC Board Ground.
- [4] Rotate Trimmer Capacitor TC-15 until Frequency Counter indicates from 11.275 to 11.2752 MHz.
- [5] Adjust potentiometer RV-1 for an output voltage reading of 0.6V on VTVM.
- [6] Set MODE Switch to LSB position.
- [7] Adjust potentiometer RV-2 for an output voltage of 0.6V on VTVM.
- [8] Rotate Trimmer Capacitor TC-16 until Frequency Counter indicates from 11.2718 to 11.2720 MHz.

2. TRANSMITTER ALIGNMENT

NOTE: The following adjustment has already been made at the factory in SSB and AM Modes. Unauthorized personnel should not perform Step A, otherwise serious damage to the equipment may occur.

A. RF Power Output Adjustment

WARNING: Personnel must have 2nd Class FCC License.

- [1] Connect 50 ohm Dummy Load and Watt Meter to ANT Connector.
- [2] Set MODE Switch to AM position.
- [3] Adjust the power source voltage to 13.8 volts.
- [4] Set Channel Selector Switch to CH-13.
- [5] Depress Microphone PUSH-TO-TALK button and adjust L5, L6, L7, L8, L11, L12, L13, L14, L15, L16, L18, L19 and TC-18 for maximum indication on Watt Meter.

NOTE: The adjustment of L10 is very critical if low output is obtained after the above alignment, then L10 must be adjusted for maximum output.

- [6] Using Channel Selector Switch, select other channels and read the power output of each. Adjust L11 thru L14 so that power output is approximately the same on all channels.

- [7] Set Channel Selector Switch to CH-13 and adjust L18, L19 and TC-18 for a maximum indication on the Watt Meter.

B. SSB Transmission Adjustment

- [1] Driver [Q12] and Final [Q13] Stage Adjustment.
 - [a] Adjust DC power source to 13.8V and connect 50 ohm Dummy Load to ANT Connector.
 - [b] Set MODE Switch to USB position.
 - [c] Connect DC VTVM between Q12 Emitter [TP-13] and PC Board Ground.
 - [d] Open jumper wire TP-14 located on power source side of Q13 and connect DC Ammeter between them.
 - [e] Depress microphone PUSH-TO-TALK button but do not talk [modulate] into it.
 - [f] Adjust variable resistor RV-4 for a 0.04V indication on VTVM.
 - [g] Adjust variable resistor RV-5 for a 10mA indication on DC Ammeter.

CAUTION: If the Carrier Balance Adjustment which follows is not performed exactly as specified, the DC Ammeter may malfunction. In order to avoid this trouble, remove bottom cover of transmitter and connect a 0.047 MFD capacitor between the Q12 collector and PC Board Ground before starting this adjustment.

[2] Carrier Balance Adjustment

- [a] Adjust DC power source to 13.8V.
- [b] Connect 50 ohm Dummy Load to ANT Connector and then connect RF Probe of VTVM between both ends of Dummy Load.
- [c] Set MODE Switch to LSB position.
- [d] Depress Microphone PUSH-TO-TALK button, but do not talk [modulate] into it.
- [e] Adjust variable resistor RV-3, Trimmer Capacitor TC-17 and L9 for a minimum indication on VTVM. An average reading is 0.3V or less.
- [f] Set MODE Switch to the USB position. The reading should be the same as that found in Step 2e.

NOTE: The following adjustment has already been adjusted in the factory. Unauthorized personnel should not perform this step.

[3] SSB Modulation Adjustment

- [a] Set MODE Switch to LSB position.
- [b] Connect 50 ohm Dummy Load to ANT Connector. Connect a Watt Meter also to the ANT Connector.
- [c] Connect a oscilloscope as shown in Figure 1.

- [d] Connect a single tone generator to the input of C121 [center pin of J-2 microphone jack]. And adjust L10 for Maximum RF Power output.
- [e] Connect a Two-Tone Generator to the input of C121 [center pin of J-2 microphone jack].
- [f] Set output of Two-Tone Generator to ten [10] mV.

- [g] Adjust variable resistor RV-9 for 100% modulation on oscilloscope [see Figure 2 for proper wave shape].

C. RF Meter Adjustment

- [1] Set MODE Switch to AM position.
- [2] Adjust variable resistor RV-6 [looking at RF Meter mounted on Front Panel], in order to obtain the same reading as on Watt Meter.

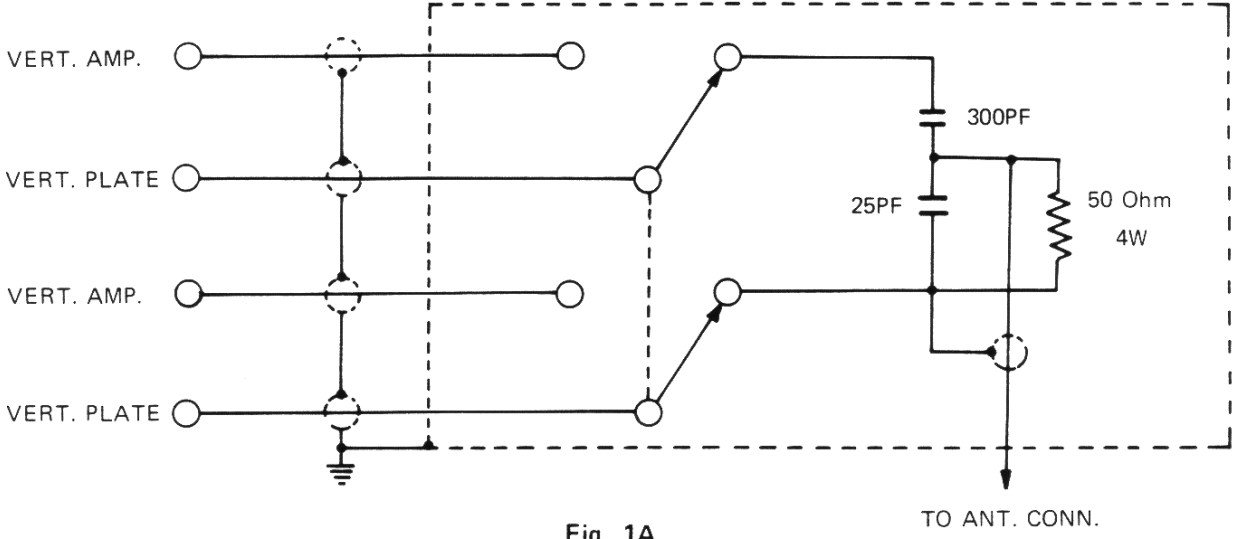

Fig. 1A

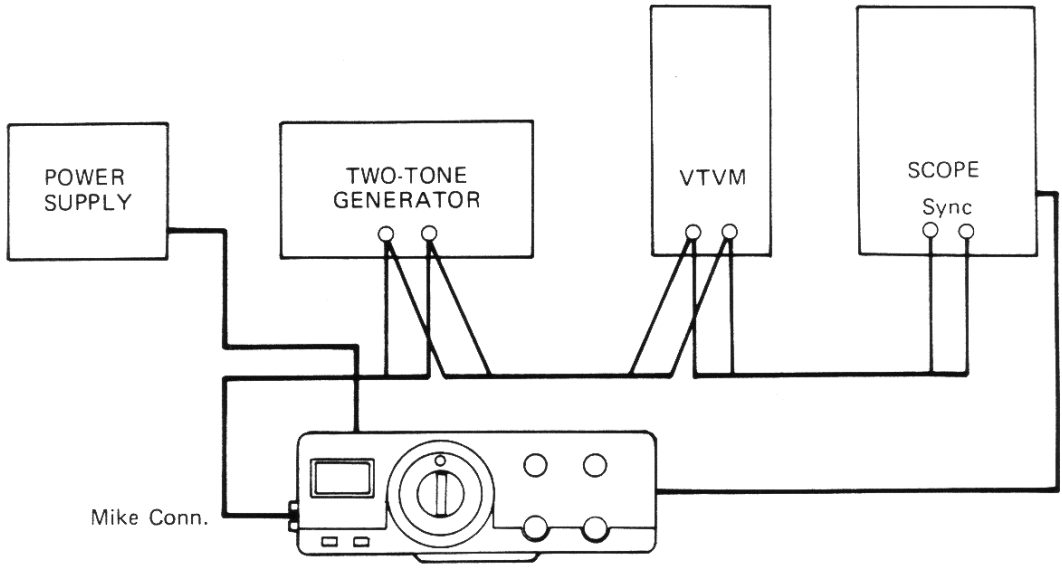

Fig. 1B

Fig. 1 Circuit and equipment connections required to make SSB Modulation and Transmitter adjustment. (A) Circuit required to modify oscilloscope. (B) Instrument connection to perform the test.

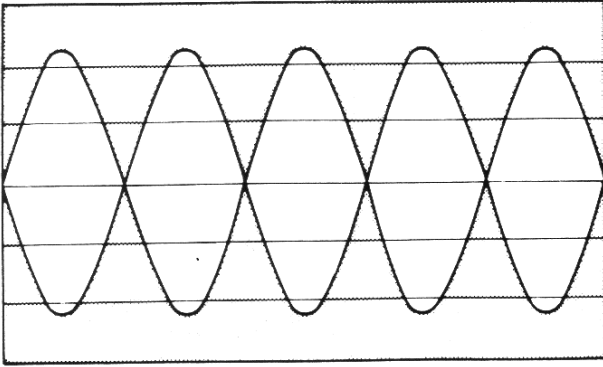

Fig. 2A

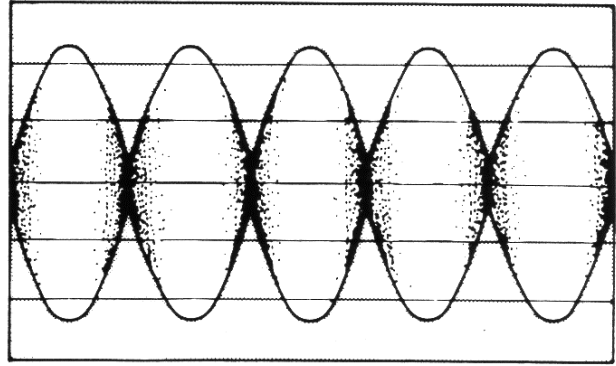

Fig. 2B

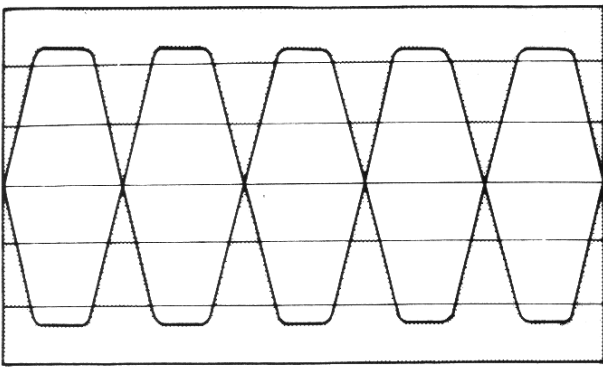

Fig. 2C

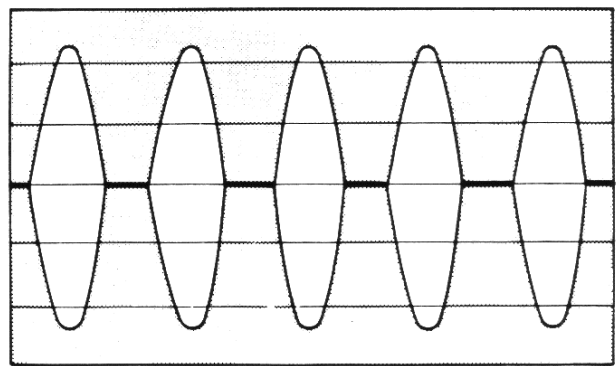

Fig. 2D

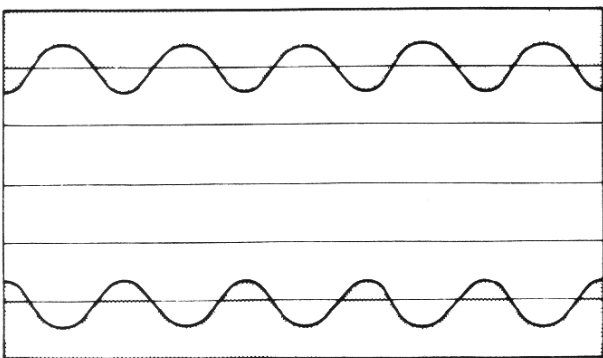

Fig. 2E

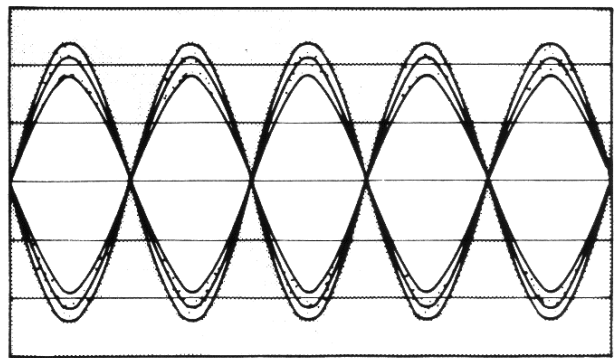

Fig. 2F

Fig. 2 SSB Modulation Envelopes. (A) Properly adjusted transmitter. (B) Unequal tones. (C) Excessive drive, causing flattopping and distortion. (D) Final amplifier incorrectly biased. (E) Single tone showing modulation pattern caused by partially suppressed carrier. (F) Similar to A but showing hum on signal.

D. Range Boost Adjustment on AM Transmission

- [1] Connect Modulation Monitor to the Transceiver.
- [2] Connect an Audio Generator between PC Board Ground and the center pin of the Microphone Connector J2 on the Transceiver.
- [3] Set Audio Generator to 1 KHz and adjust output level to 20mV.
- [4] Apply power to the Transceiver and depress microphone PUSH-TO-TALK button.
- [5] Adjust potentiometer RV-8 for 80% modulation indication on Modulation Monitor.

NOTE: The above steps will produce 100% modulation on voice signals. In no case shall the modulation exceed 100%.

E. TVI Adjustment

- [1] Use a TV Receiver set to Channel 2 as an indicator.
- [2] Depress the Microphone PUSH-TO-TALK button and adjust L-20 which is marked TVI on chassis [located at the rear of the Transceiver] for minimum interference on TV Receiver.

3. RECEIVER ADJUSTMENT

A. AM Reception Adjustment.

- [1] Second Local Oscillator [Q33] Adjustment.
 - [a] Set MODE Switch to AM position.
 - [b] Connect DC VTVM between Q33 Emitter [TP-24] and PC Board Ground.
 - [c] Move the L33 core to the top end of bobbin. Then screw down the core slowly, the VTVM reading will increase rapidly. Turn down the core 1/8 turn after reaching the maximum indication on VTVM.
- [2] RF and IF Alignment.
 - [a] Connect an RF Signal Generator to the ANT Connector.
 - [b] Connect an AC VTVM across Speaker Terminals.
 - [c] Rotate VOLUME control to the 12 o'clock position.
 - [d] Set NS/ANL Switch to ANL position.
 - [e] Rotate FINE TUNE control to 12 o'clock position.
 - [f] Rotate SQUELCH control fully counter-clockwise.
 - [g] Set RF Signal Generator to 27.115 MHz [CH-13] for 30% modulation with 1 KHz tone and adjust its output level to 10 μ V.
 - [h] Set Channel Selector switch to CH-13 and Signal Generator frequency to approximately

27.115 MHz for a maximum indication on AC VTVM.

- [i] Adjust L22, L23 and L24 for a maximum output indication on AC VTVM.
- [j] Decrease RF Signal Generator output to approximately 1 μ V.
- [k] Adjust L22, L23, L24, L25, L26, Mechanical Filter [MF], L27, L28, and L29 for a maximum indication on AC VTVM. Re-adjust all coils until no further improvement is obtainable.
- [l] Increase RF Signal Generator output level to 100 μ V.
- [m] Adjust variable resistor RV-14 until S-Meter scale indicates S-9.
- [n] Rotate SQUELCH control fully clockwise.
- [o] Increase RF Signal Generator output level to 10 mV.
- [p] Adjust variable resistor RV-15 so that the audio output on AC VTVM becomes half of that obtained in Step [o].

B. SSB Reception Adjustment

[1] IF Alignment

NOTE: IF Alignment has already been performed at the factory. These steps should not be performed by Unauthorized Personnel.

There are no adjustments in SSB Mode. If the IF alignment in AM Mode is performed properly, the IF will automatically be aligned in SSB [see Step 3A2, RECEIVER ADJUSTMENT].

[2] Sensitivity Check for SSB Reception

- [a] Connect RF Signal Generator to ANT Connector.
- [b] Connect AC VTVM and Oscilloscope across Speaker Terminals.
- [c] Set MODE Switch to LSB position.
- [d] Set NS/ANL Switch to ANL position.
- [e] Rotate VOLUME control to 12 o'clock position.
- [f] Rotate SQUELCH control fully counter-clockwise.
- [g] Set RF Signal Generator for 27.115MHz [CH-13]. Do not modulate. Set RF Signal Generator output level at 10 μ V.
- [h] Set Transceiver to CH-13 and vary RF Signal Generator frequency to approximately 27.115 MHz for maximum indication on AC VTVM.
 - [i] Rotate FINE TUNE control until an audio output of about 1KHz [beat frequency] is obtained on the scope.
 - [j] Adjust L21 for maximum audio output.

- [k] Increase the output of signal generator again and when the reading on AC VTVM becomes 3.2 times of the Noise Level, read the output on Signal Generator. This output should be less than $0.2\mu\text{V}$.

NOTE: The following adjustment has already been done in the factory. Therefore, Unauthorized Personnel should not perform this step.

[3] AGC Alignment

- [a] Connect RF Signal Generator to ANT Connector.
- [b] Connect AC VTVM to Speaker Terminals.
- [c] Adjust variable resistor RV-11 so that the voltage between the tap of RV-11 and chassis ground becomes 1.2V, using DC VTVM.
- [d] Adjust RF Signal Generator output to $10\mu\text{V}$ and read the indication on AC VTVM.
- [e] Increase RF Signal Generator output to 100mV and adjust variable resistor RV-10 for an indication of 10db greater than value found in Step [d] above.

[4] S-Meter Alignment

- [a] Upon completion of the above steps, adjust the RF Signal Generator output [two-tone modulated] to $100\mu\text{V}$.
- [b] Adjust variable resistor RV-13 for an indication of S-9 on S-Meter.

[5] Squelch Alignment

- [a] Upon completion of the above steps, rotate SQUELCH control fully clockwise and adjust the RF Signal Generator [two-tone modulated] output to $10\mu\text{V}$.
- [b] Adjust variable resistor RV-12 until you are able to hear sound from speaker.

C. Noise Silencer Alignment

- [1] Set NS/ANL Switch to NS position.
- [2] Set MODE Switch to AM position.
- [3] Set Channel Selector Switch to CH-1 position.
- [4] Connect DC VTVM [-DC reading] between output side of D-41 and negative side of EXTERNAL JACK [PC Board Ground].
- [5] Connect RF Signal Generator to ANT Connector.
- [6] Set RF Signal Generator for 26.965 MHz [CH-1] No-Modulation and increase output level until a -DC reading is obtained on DC VTVM. Then, adjust L30 and TC-19 for a minimum indication on DC VTVM.
- [7] Set RF Signal Generator for 25 MHz and adjust L31 and L32 for a maximum -DC indication on DC VTVM.

- [8] Connect Oscilloscope between the output of D-41 and PC Board Ground.
- [9] Connect Square Wave Generator, VTVM, Signal Generator, and Transceiver to test fixture as shown in Figure 3.
- [10] Set selector switch on test fixture to "Square Wave Generator" position.
- [11] Adjust the output of the Square Wave Generator to approximately 1.0 volt. At this point set the NS/ANL switch to the "ANL" [released] position and see the pulse at the output, then reset the NS/ANL switch to the "NS" [depressed] position.
- [12] Set selector switch on test fixture to the "Signal Generator" position and adjust the signal generator output to $1\mu\text{V}$.
- [13] Set selector switch on test fixture to the "BOTH" position. If the Noise Silencer is properly adjusted, only the signal from the Signal Generator will be heard.
- [14] If the Noise Silencer is not properly adjusted, noise will still be present. If this is the case, realign TC-19, TC-20, L-31, L-32, and L-33 to eliminate or reduce as much as possible the noise pulse.

NOTE: When the selector switch on the test fixture is set to the "BOTH" position a condition could exist where neither the signal or noise is heard. In this case, set the NS/ANL switch to the "ANL" [released] position. If the signal and the noise are both heard, then the gain of the Noise Silencer Amplifier is too high, therefore even the normal background noise will cut-off the I.F. If this condition occurs set the NS/ANL switch to the "NS" [depressed] position and realign L-31 very slightly to bring in the signal without the noise.

- [15] Reduce the output of the Square Wave Generator. If at a lower noise level the noise pulses reappear, repeat steps 13 and 14.

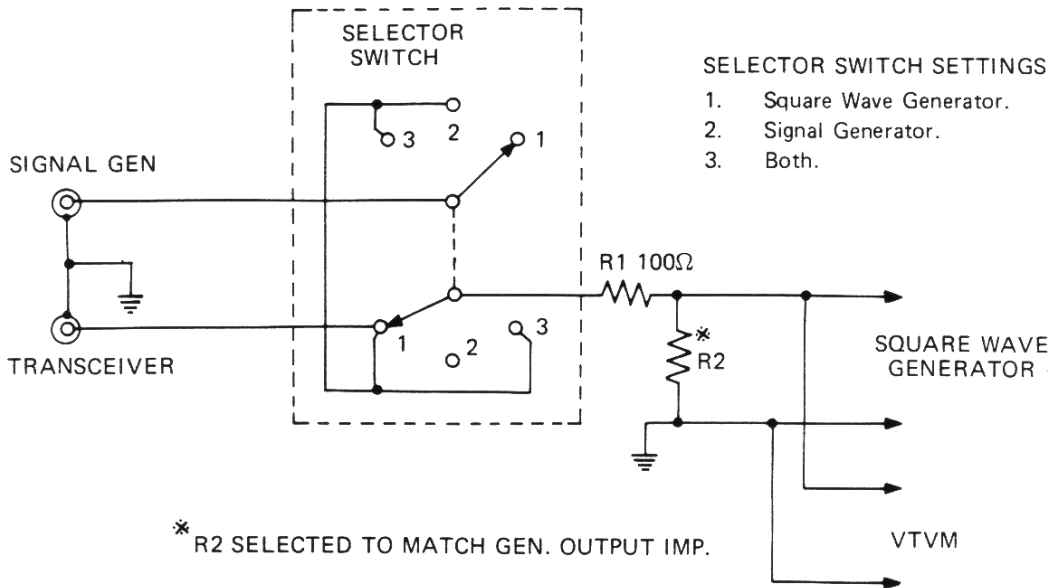
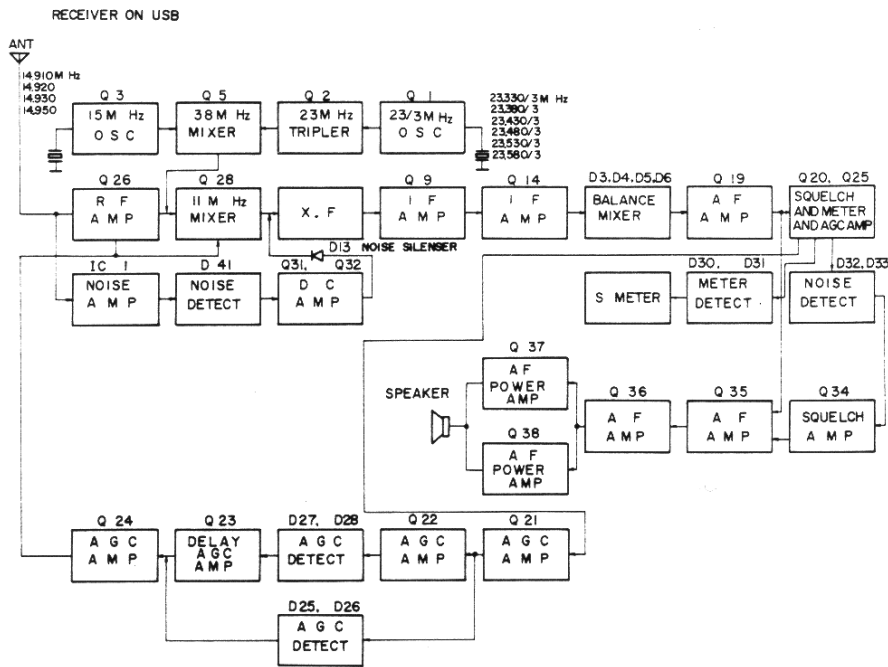

FIGURE 3. NOISE SILENSER ADJ TEST FIXTURE

BLOCK DIAGRAMS



BLOCK DIAGRAM A

TRANSMIT ON LSB

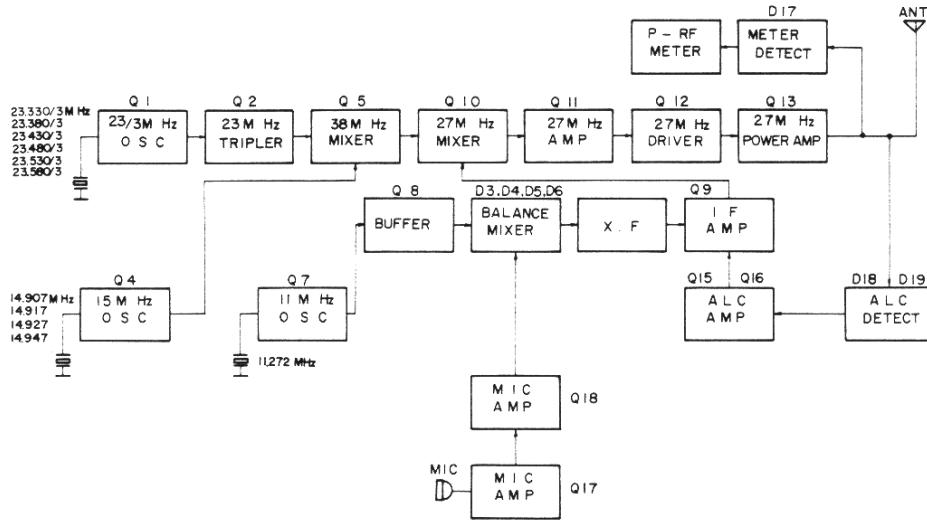

BLOCK DIAGRAM B

RECEIVER ON LSB

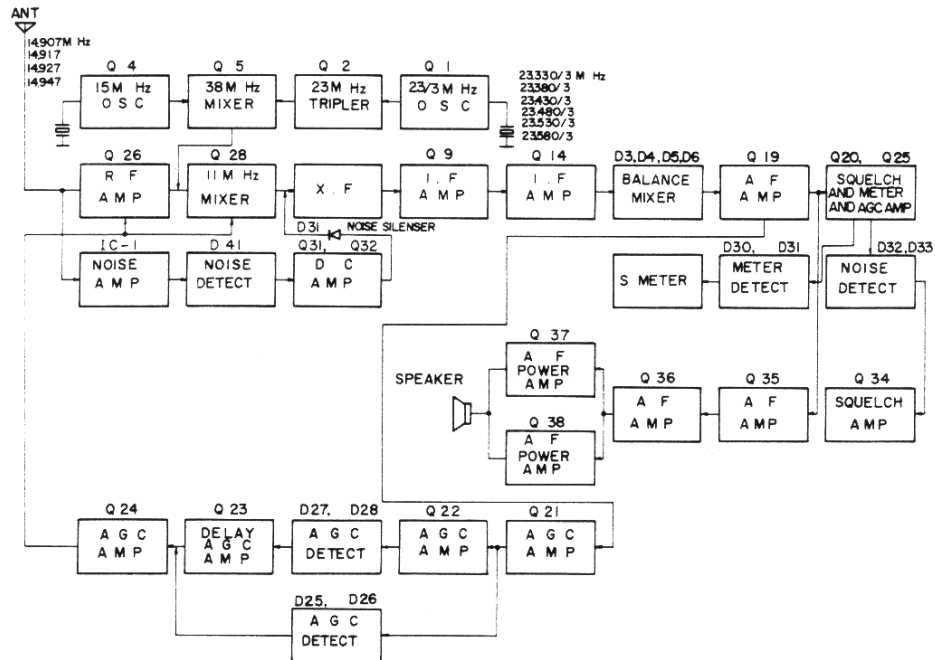

BLOCK DIAGRAM C

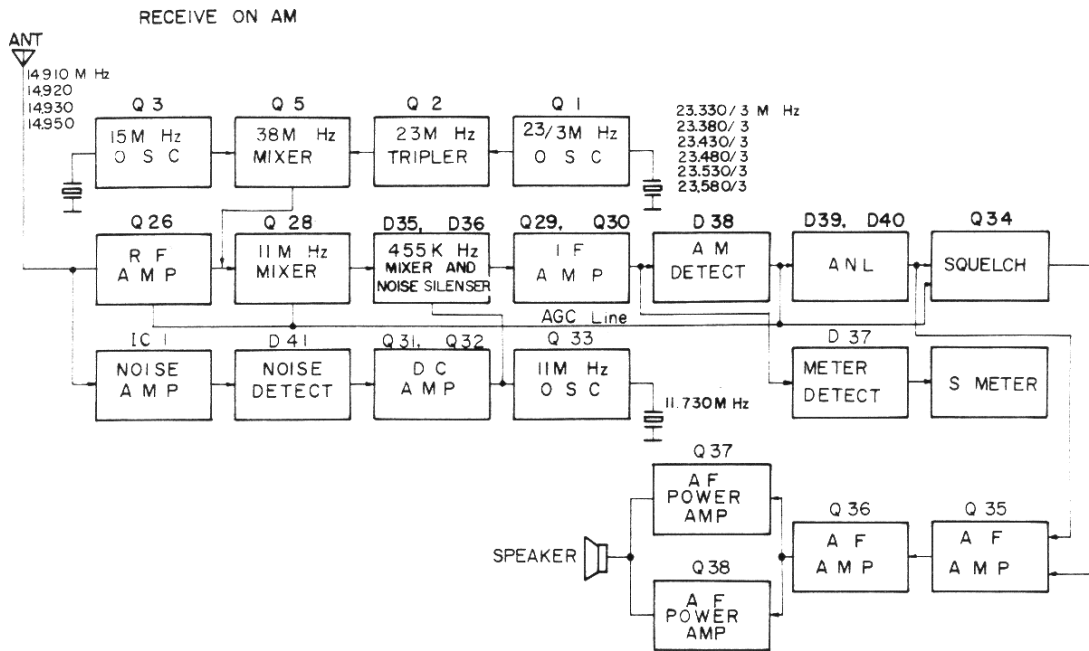

BLOCK DIAGRAM D

TRANSMIT ON USB

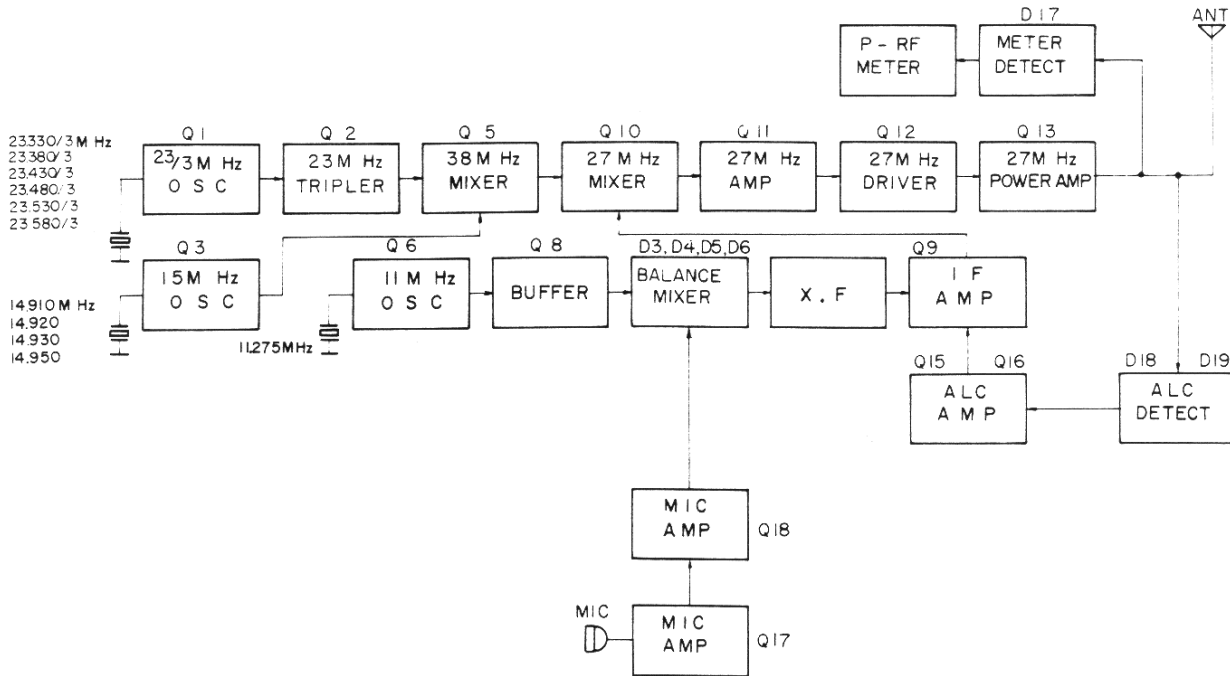

BLOCK DIAGRAM E

TRANSMIT ON AM

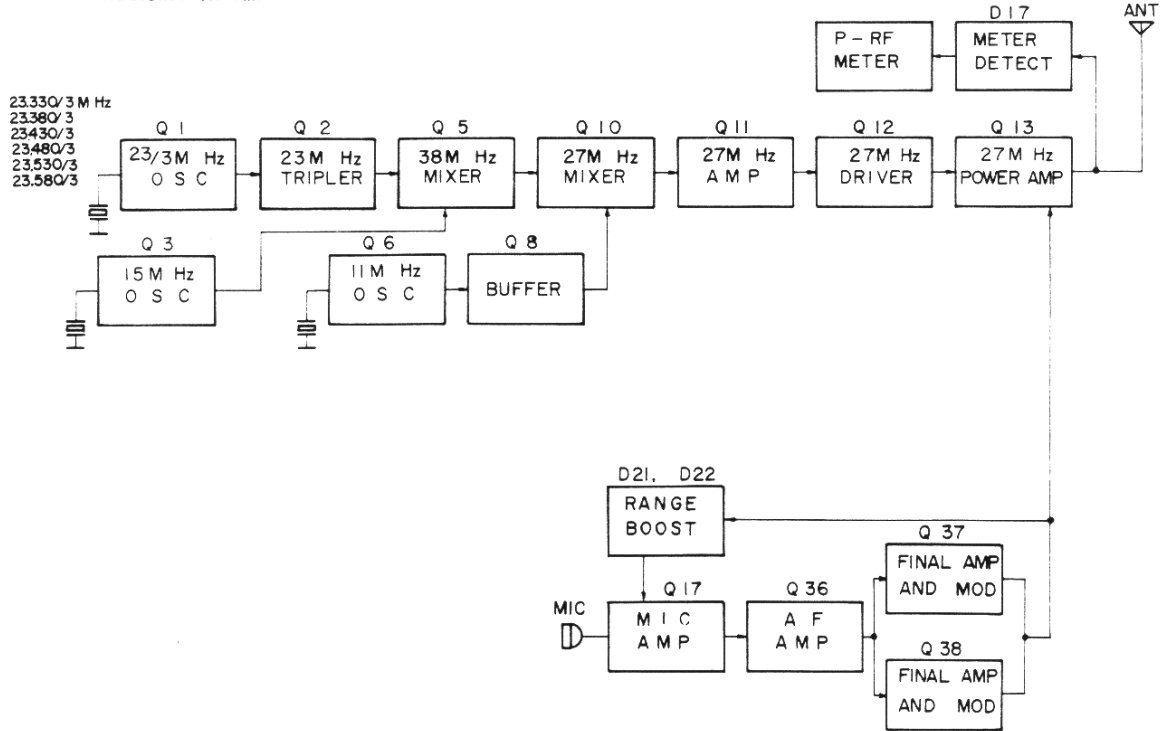

BLOCK DIAGRAM F

ELECTRICAL PARTS LOCATION (PC BOARDS)

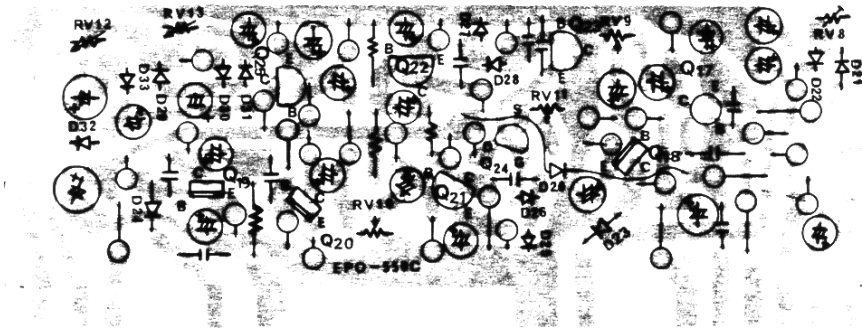

AGC CIRCUIT

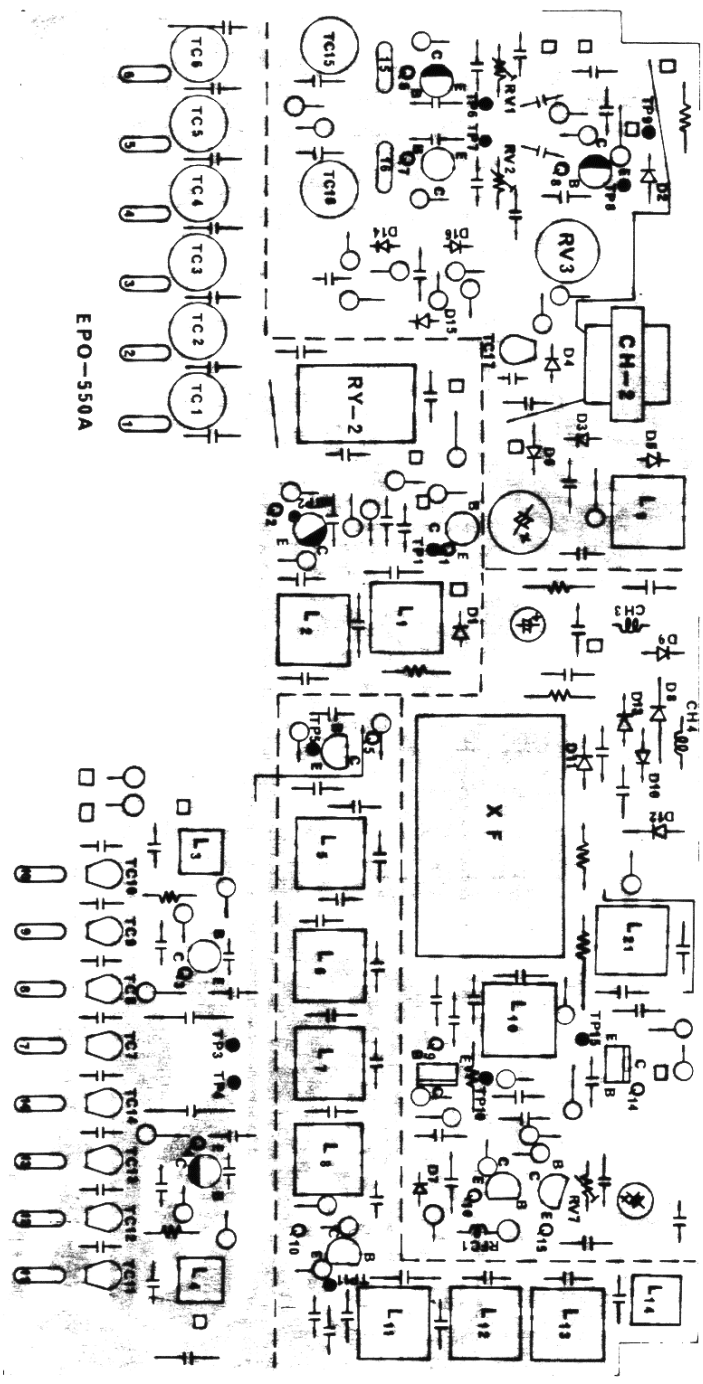

EPO-550A

SYNTHESIZER CIRCUIT

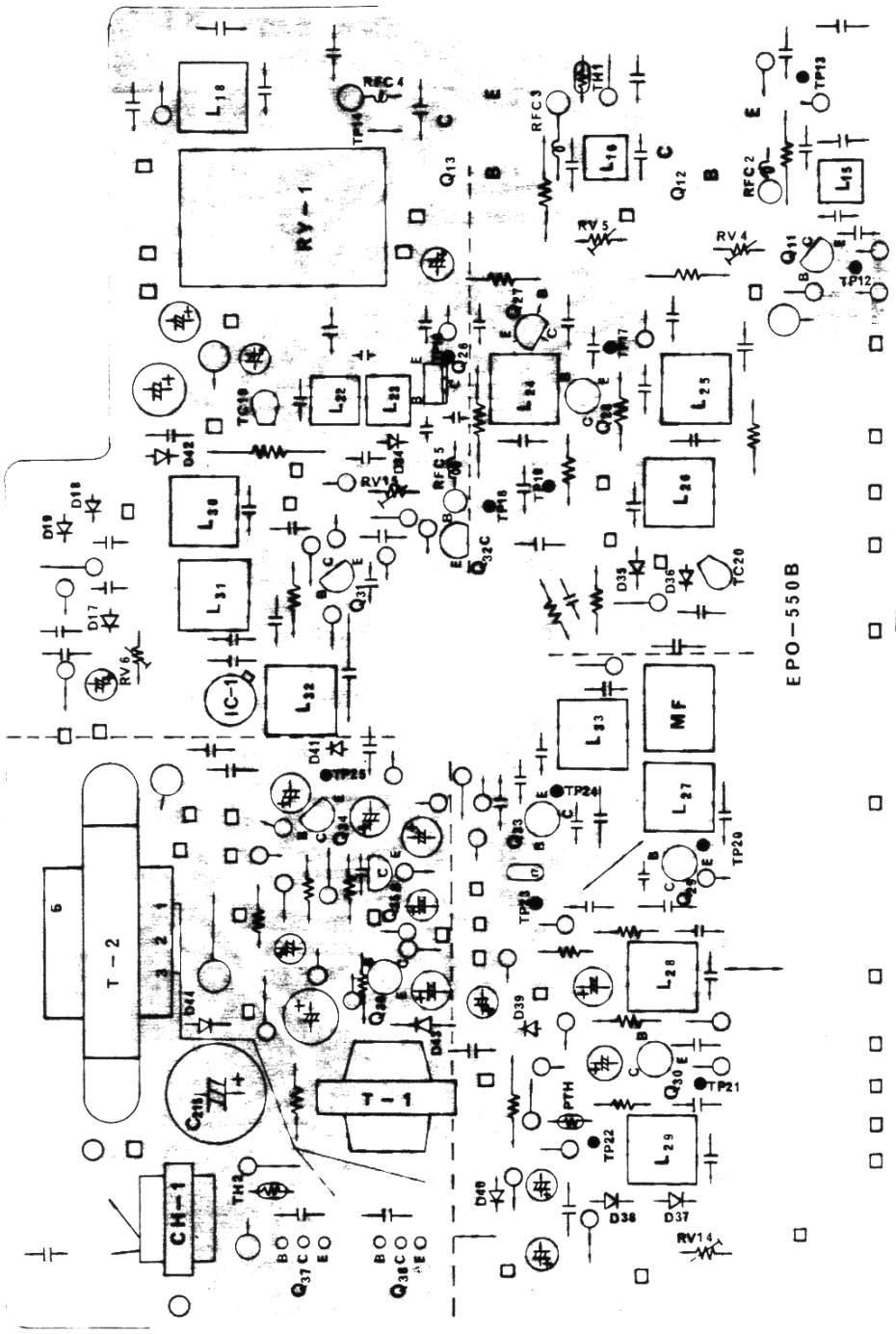

RECEIVE & TRANSMIT CIRCUITS

MECHANICAL PARTS LOCATION

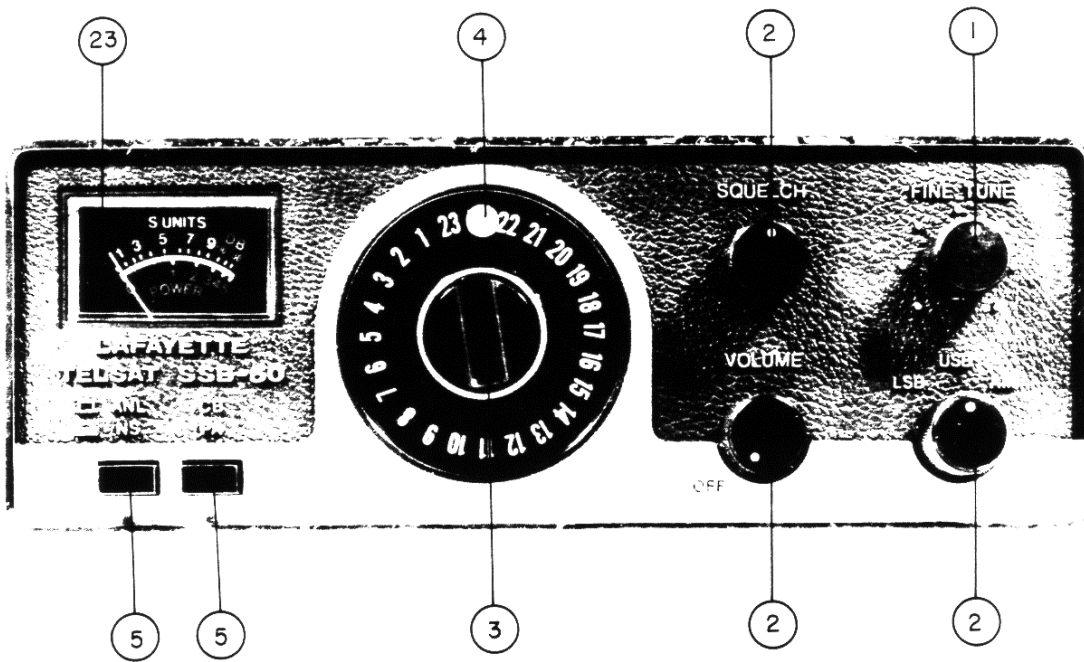

FRONT PANEL MECHANICAL PARTS LOCATION

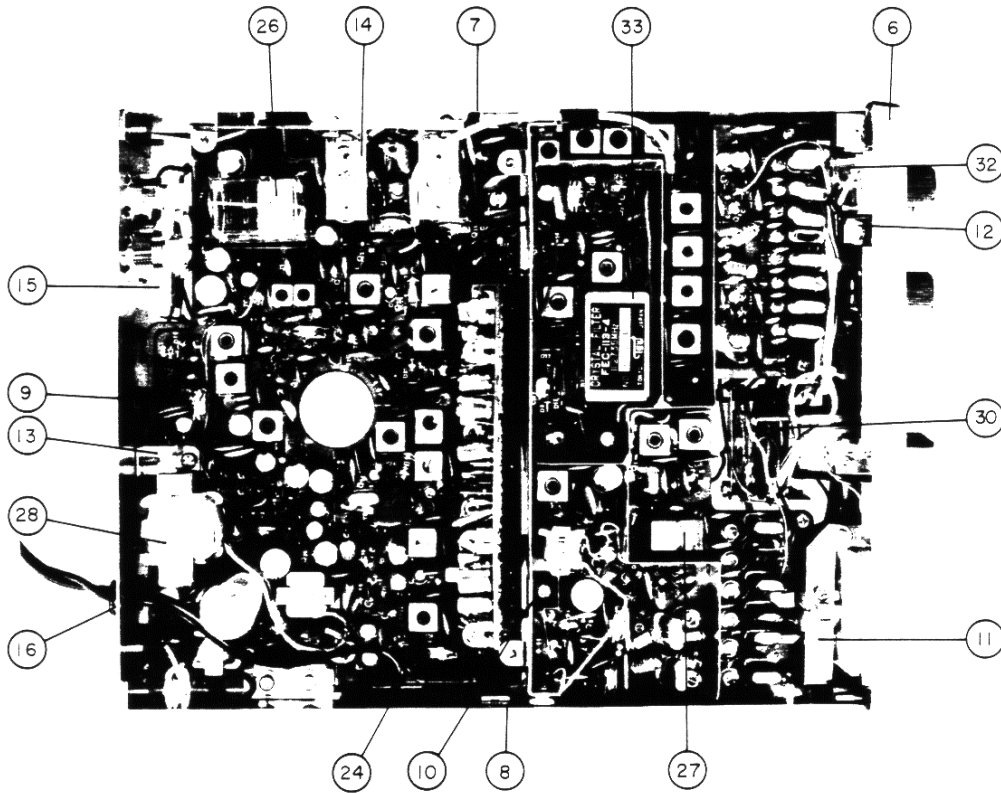

INTERNAL MECHANICAL PARTS LOCATION [TOP VIEW]

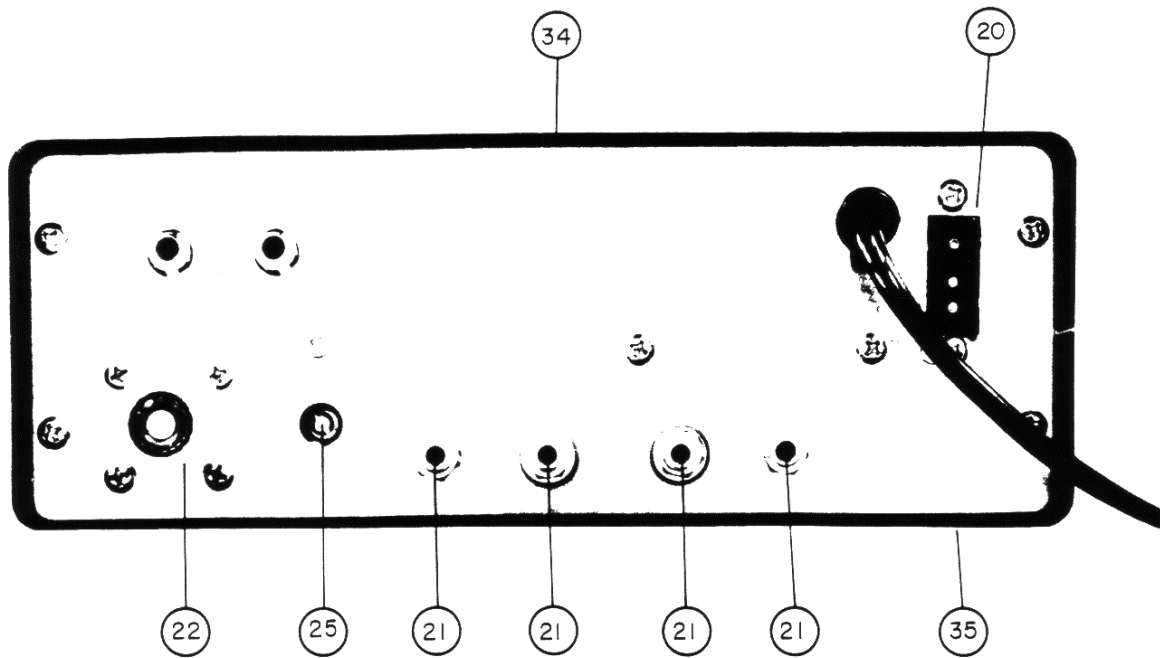

REAR PANEL MECHANICAL PARTS LOCATION

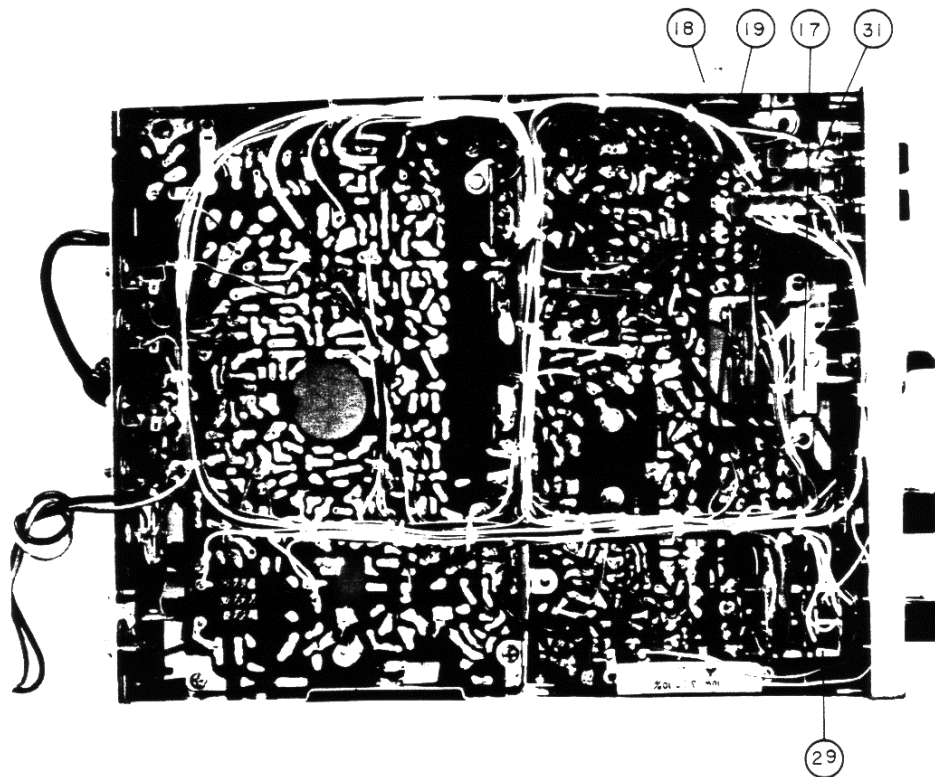

INTERNAL MECHANICAL PARTS LOCATION [BOTTOM VIEW]

COMPLETE PARTS LIST

Symbol No.	Description	Lafayette Stock No.	Symbol No.	Description	Lafayette Stock No.
(6)	Escutcheon Trim	7801-10	C97	22PF Ceramic	3528-12
(7)	Chassis (Right)	7802-10	C178	.047 μ F Ceramic Cap.	3320-12
(8)	Chassis (Left)	7803-10	C219	.001 μ F Ceramic	3394-12
(9)	Chassis (Rear)	7804-10	C158	27 PF Ceramic	3529-12
(10)	Chassis (Middle)	7805-10	C199	39 PF Ceramic	3026-12
(34)	Cage (Upper)	7806-10	C81	8 PF Ceramic	3530-12
(4)	Channel Dial Plate	7808-10	C92	1000 PF Ceramic	3531-12
(35)	Cage (Lower)	7807-10	C206	2200 PF Ceramic	3532-12
	Black Channel Plate	7809-10	C100	2 PF Ceramic	3533-12
	Mobile Mounting Bracket	7810-10	C166	6 PF Ceramic Cap.	3534-12
(12)	VC Mounting Bracket	7811-10	C66	10 PF Ceramic Cap.	3535-12
(13)	Mounting Bracket (Output Transf.)	7812-10	C46	68 PF Ceramic Cap.	2008-12
(17)	Stiffner (P.C. Board)	7813-10	C41, 43	47 PF Ceramic Cap.	3061-12
(14)	Heat Sink (Q-12, 13)	7814-10	C27,36	100 PF Ceramic Cap.	3197-12
	Shield Plate (Bal. Mod.)	7815-10	C224	180 PF Ceramic Cap.	3536-12
	Shield Plate (Synthesizer)	7816-10	C1,2,3	56 PF Ceramic Cap.	3196-12
	Shield Plate (IF)	7817-10	C24,25	68 PF Ceramic Cap.	2995-12
(11)	Mounting Bracket (Meter)	7818-10	C11	220 PF Ceramic Cap.	3021-12
	Mounting Bracket (R) (P.C. Board)	7819-10	C96	270 PF Ceramic Cap.	3537-12
	Mounting Bracket (L) (P.C. Board)	7820-10	C88, 95	330 PF Ceramic Cap.	3538-12
	Felt (Ch. Sel. Sw.)	7821-10	C149	100 PF Ceramic Cap.	2972-12
	Felt (Mobile Mounting Bracket)	7822-10	C13, 17	150 PF Ceramic Cap.	3539-12
(19)	Mounting Bracket (Mic. Jack)	7823-10	C84, 86	.01 μ F Ceramic Cap.	3047-12
	Serial Number Plate	7824-10	C101	.02 μ F Ceramic Cap.	3540-12
	Mounting Bracket (Speaker)	7825-10	C152	5 PF Ceramic Cap.	3541-12
	Mounting Bracket (Thermistor)	7503-10	C7, 40	3 PF Ceramic Cap.	3542-12
	Knurled Screw	2701-10	C125	.1 μ F Ceramic Cap.	3241-12
	Channel Dial Bushing	7826-10	C108	.2 μ F Ceramic Cap.	3543-12
	Insulating Sheet (Q12, 13)	6331-10	C47	.022 μ F Ceramic Cap.	3360-12
	Relay Spring	5834-10	C142	5 μ F Ceramic Cap.	3544-12
	Lamp Holder	1772-10	C218	33 μ F 16V Elyt. Cap.	3104-12
(18)	Mic. Mounting Clip	2290-10	C145	10 μ F 10V Elyt.	3102-12
	Mic. Guide	4221-10	C127	33 μ F 10V Elyt.	3089-12
	Insulating Bush (Phone Jack)	6639-10	C143	47 μ F 10V Elyt.	3235-12
	Insulating Washer (Phone Jack)	6640-10	C201	100 μ F 10V Elyt.	3004-12
	Serial Number Tag	7589-10	C62	10 μ F 16V Elyt.	2986-12
(15)	Trimmer Mounting Bracket		C210	100 μ F 16V Elyt. Cap.	3078-12
VR1	Volume Control	1608-11	C215	2200 μ F 16V Elyt.	3545-12
VR2	Squelch Control	1609-11	C180	3.3 μ F 25V Elyt.	3191-12
(32)	Variable Capacitor	3527-12	C119	4.7 μ F 25V Elyt.	3090-12
(25)	Trimmer Capacitor	2930-12	C102	1 μ F 50V Elyt.	3073-12
C99	15PF Ceramic	2996-12	C65	CR Module	3435-12
			C67	CR Module	3546-12
			TC1-6	Trimmer Capacitor	3547-12
			TC7-14	Trimmer Capacitor	3548-12

Symbol No.	Description	Lafayette Stock No.
TC15, 16	Trimmer Capacitor	3549-12
C129	2200 P Mylar Cap.	3117-12
C49, 54	180 P Styroflex Cap.	3550-12
	220 P Styroflex Cap.	3551-12
	510 P Styroflex Cap.	3552-12
	820 P Styroflex Cap.	3553-12
	1000 P Styroflex Cap.	3554-12
R168	Wirewound Resistor	2473-13
R171	3.3 Ohm Cement Res.	2595-13
RV5	500 Ohm Pot.	2586-13
RV6, 15	10K Ohm Pot.	2596-13
RV14	5K Ohm Pot.	2597-13
RV1, 2	1K Ohm Pot.	2598-13
RV7	2K Ohm Pot.	2599-13
R173	8.2 Ohm Solid Res.	2572-13
R19	47 Ohm Solid Res.	2600-13
R20, 21	100 Ohm Solid Res.	2601-13
(30)	Rotary Switch (Ch. Sel.) (SW1)	1730-14
(24)	Leaf Switch " (SW4)	1733-14
(31)	Push Switch " (SW3)	1871-14
(29)	Rotary Switch (AM/USB/LSB)	1872-14
(28)	Audio Transformer (T2)	1718-15
CH1, 2	Audio Choke Transformer	1090-15
	P.C Board (Synthesizer)	1580-16
	P.C Board (Transmit/Receive)	1581-16
	P.C. Bd. (AGC/Mic. Amp.)	1582-16
Q12	2SC-777	2062-17
Q13	2SC-1239	2167-17
Q37, 38	2SC-1096 (M)	2168-17
Q17	2SB-77 (B)	1060-17
Q26	2SC-460 (A)	1373-17
Q2, 28	2SC-184 (R)	1634-17
Q1, 3, 4	2SC-183 (R)	1210-17
Q5, 10	2SC-815	1879-17
Q9, 14	2SC-458LGB	1374-17
Q21, 22	2SC-945 (R)	2063-17
Q15, 16	2SC-900 (F)	2132-17
Q24	2SK-19GR	2074-17
D17, 21	1N-60 Diode	1000-17
D34	1N-60 Diode (P)	2151-17
D44	V06B Diode	2031-17
D8, 9, 10	1S-953 Diode	2066-17
D7, 14	M1-301 Diode	2065-17
D2, 42	AW-01-08 Diode	2064-17
D1	AW-01-09 Diode	2150-17

Symbol No.	Description	Lafayette Stock No.
Pth	Posistor	2169-17
TH1	Thermistor	2038-17
TH2	Thermistor	2170-17
(5)	Knob (Push Switch)	1839-18
(3)	Knob (Ch. Sel.)	1735-18
(1)	Knob (Fine Tune)	1737-18
(2)	Knob (VR/SQ. Mode)	1840-18
	5P Lug Terminal	1984-19
(22)	Antenna Jack (J1)	1019-19
	Mic. Jack (J2)	1229-19
(21)	Phone Jack (J3, 4, 5, 6)	1411-19
(20)	Power Jack (J7)	1017-19
	Fasten Receptacle	1924-19
	Relay Socket	1226-19
	Polarity Changer (Male)	1816-19
	Polarity Changer (Female)	1815-19
	Tie Point	1891-19
PL1, 2	Pilot Lamp	1003-20
	Test Point	4279-20
	Spacer (Crystal Osc.)	4314-20
	Antenna Jack Cap.	4055-20
	Speaker Magnet Cap.	3602-20
(16)	Strain Relief	3945-20
L20	RF Coil	2216-23
L19	RF Coil	2489-23
RFC-6	RF Choke Coil	2217-23
RFC-1,2,3	RF Choke Coil	2240-23
CH3, 4	RF Choke Coil	2490-23
L10, 21	IFT Transformer	2493-23
L3, 4	RF Transformer	2219-23
L5, 11, 12	RF Transformer	2220-23
L6, 7	RF Transformer	2221-23
L8	RF Transformer	2222-23
L14	RF Transformer	2494-23
L1, 2	RF Transformer	2491-23
L9	RF Transformer	2492-23
T1	Input Transformer	2084-24
L29	IFT Transformer	1949-24
L26	IFT Transformer	2017-24
L27	IFT Transformer	2036-24
L28	IFT Transformer	2008-24
L25	IFT Transformer	2085-24
L22, 23	RF Transformer	2032-24
L15, 16	RF Transformer	2028-24
L33	RF Transformer	2041-24

Symbol No.	Description	Lafayette Stock No.
L24	RF Transformer	2033-24
L30	RF Transformer	2039-24
L31	RF Transformer	2040-24
L32	RF Transformer	2042-24
L18	RF Transformer	2030-24
MF	Mechanical Filter	2043-24
IC	CA-3011 I.C.	1002-25
(23)	S-P RF Meter (M1)	1179-27
	Manual	1763-30
MIC	Microphone	1083-34
(33)	Crystal Filter (XF)	1297-35
Xtal-16	11.272 MHz	1278-35
Xtal-15	11.275 MHz	1096-35
Xtal-17	11.730 MHz	1097-35
Xtal-11	14.904 MHz	1274-35
Xtal-7	14.907 MHz	1270-35
Xtal-12	14.914 MHz	1275-35
Xtal-8	14.917 MHz	1271-35
Xtal-13	14.924 MHz	1276-35
Xtal-9	14.927 MHz	1272-35
Xtal-14	14.944 MHz	1277-35
Xtal-10	14.947 MHz	1273-35
Xtal-9	7.776 MHz	1264-35
Xtal-2	7.793 MHz	1265-35
Xtal-3	7.810 MHz	1266-35
Xtal-4	7.826 MHz	1267-35
Xtal-5	7.843 MHz	1268-35
Xtal-6	7.860 MHz	1269-35
SP	Speaker	1260-36
(26)	Relay (Ant./Prw.) (RY1)	1052-37
(27)	Relay (Fine Tune) (RY2)	1064-37
	D.C. Cord Assembly	1209-38