

GATE CIRCUIT SCHEMATIC DIAGRAM

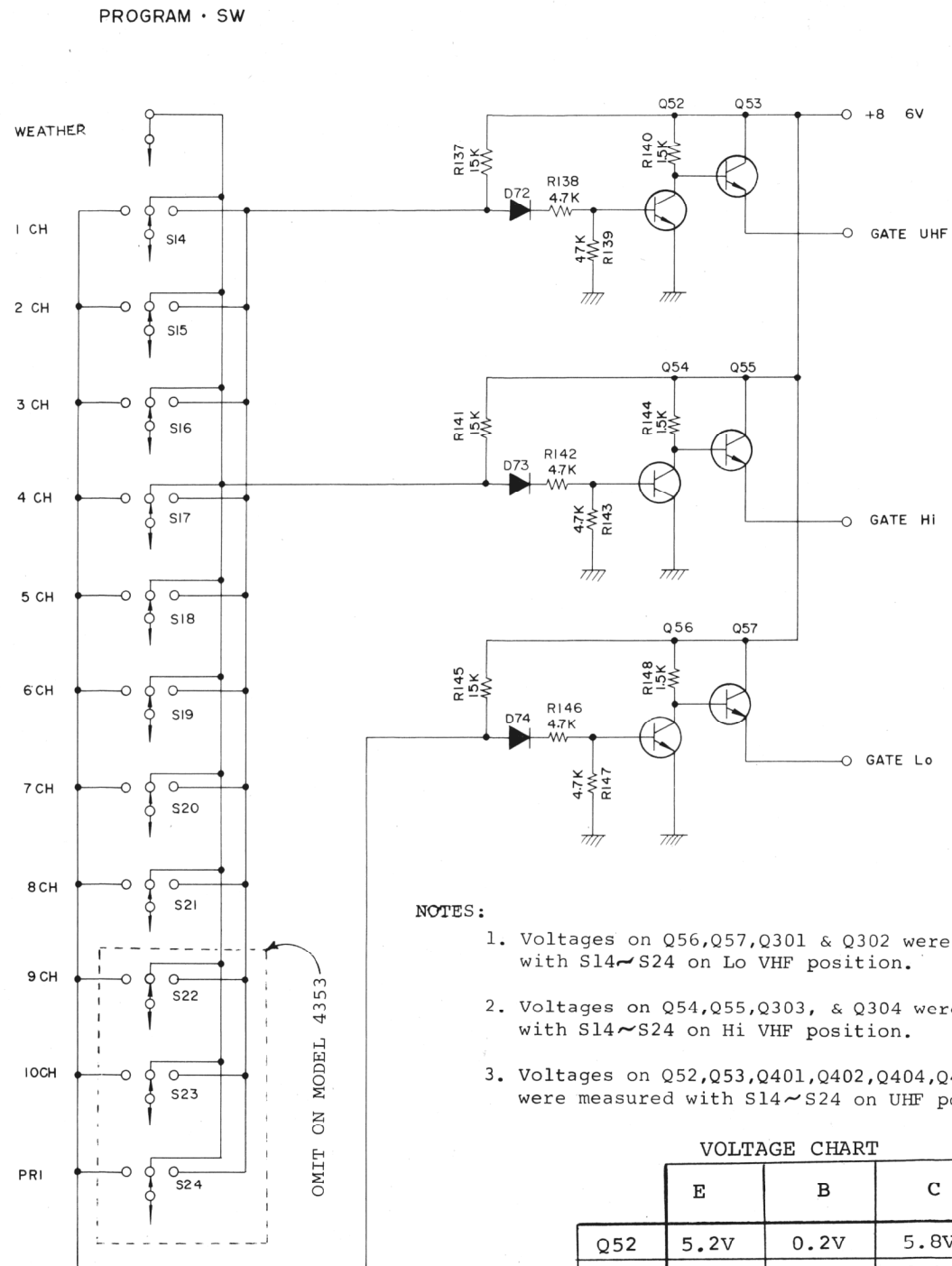

NOTES:

1. Voltages on Q56, Q57, Q301 & Q302 were measured with S14~S24 on Lo VHF position.
2. Voltages on Q54, Q55, Q303, & Q304 were measured with S14~S24 on Hi VHF position.
3. Voltages on Q52, Q53, Q401, Q402, Q404, Q405 & Q406 were measured with S14~S24 on UHF position.

VOLTAGE CHART

	E	B	C
Q52	5.2V	0.2V	5.8V
Q53	5.2V	5.8V	6.0V
Q54	0.0V	0.2V	5.8V
Q55	5.2V	5.8V	6.0V
Q56	0.2V	0.2V	5.8V
Q57	5.2V	5.8V	6.0V
Q301	1.5V	2.2V	5.8V
Q302	1.0V	1.7V	4.2V
Q303	1.6V	2.4V	5.9V
Q304	1.0V	1.8V	4.2V
Q401	1.0V	1.8V	6.0V
Q402	6.0V	1.0V	0.2V
Q404	0.9V	1.6V	5.1V
Q405	0.3V	1.0V	6.0V
Q406	0.4V	1.1V	5.6V

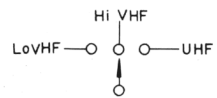

FRONT END SCHEMATIC DIAGRAM

