

This Information Is Provided By
CBTricks.com

Cobra 45XLR Service Manual

Liability of damages to any equipment is the sole responsibility of the user! Downloading, viewing, or using any information provided on these pages automatically accepts the user to the terms of this agreement!

Modifications are provided for information purposes only!

Supporters of CBTricks.com paid for the hosting so you would have this file.

CBTricks.com is a non-commercial personal website was created to help promote the exchange of service, modification, technically oriented information, and historical information aimed at the Citizens Band, GMRS (CB "A" Band), MURS, Amateur Radios and RF Amps.

CBTricks.com is not sponsored by or connected to any Retailer, Radio, Antenna Manufacturer or Amp Manufacturer, or affiliated with any site links shown in the links database. The use of product or company names on my web site is not endorsement of that product or company.

The site is supported with donations from users, friends and selling of the Site Supporters DVD's to cover some of the costs of having this website on the Internet instead of relying on banner ads, pop-up ads, commercial links, etc. Thus I do not accept advertising banners or pop-up/pop-under advertising or other marketing/sales links or gimmicks on my website.

ALL the money from donations is used for CBTricks.com I didn't do all the work to make money (I have a day job). This work was not done for someone else to make money also, for example the ebay CD sellers.

All Trademarks, Logos, and Brand Names are the property of their respective owners.

This information is not provided by, or affiliated in any way with any radio or antenna Manufacturers.

Thank you for any support you can give.

For information on how to Support CBTricks.com

<http://www.cbtricks.com/support/>



SERVICE MANUAL

45XLR



IN-DASH 40 CHANNEL CB 2 WAY MOBILE TRANSCEIVER WITH AM/FM/FM STEREO RADIO

SPECIFICATIONS

■ GENERAL

Power Supply Voltage: DC 13.8V NOM. (11V ~ 16V), Negative ground
Maximum Current

Drain: Radio: 1.5A
CB Transceiver: 2.0A

Power Output: 2 x 4 Watts (across 4 ohm load, @13.8V)

Speaker Impedance: 4 ~ 8 ohms

Semiconductors: Transistor\$; 23

FET's; 3

IC's; 8

Diodes including LED lamp & LED

Numeric Display; 25

Dimensions: Width: 7-3/32" (180 mm)

Height: 2-1/16" (52 mm)

Depth: 7-3/32" (180 mm)

Weight: Approx. 3.3 lbs (1.5 kg)

■ AM RADIO SECTION

Frequency Range: 535 ~ 1605 kHz

Intermediate

Frequency: 455 kHz

Sensitivity: Less than 20 μ V

■ FM RADIO SECTION

Frequency Range: 88 ~ 108 MHz

Intermediate

Frequency: 10.7 MHz

Maximum Sensitivity: Less than 8 μ V 18dB

Usable Sensitivity: Less than 6.3 μ V for 30dB S+N/N

Stereo Separation: More than 26 dB

■ CB RECEIVER

Channels: 40

Frequency Range: 26.965 - 27.405 MHz

Intermediate

Frequency: 1st : 10.695 MHz

2nd: 455 kHz

Sensitivity: Less than 0.5 μ V

Selectivity: 5 kHz @ -6dB

Adjacent Channel

Rejection: More than 45 dB

Image Rejection: More than 60 dB

Squelch Sensitivity: Less than 1.4 μ V 0.5 μ V

■ CB TRANSMITTER

Channels: 40

Frequency Range: 26.965 ~ 27.405 MHz

Frequency Tolerance: \pm 0.005%

RF Output Power: 3.8 Watts

Modulation

Capability: 80 ~ 100%

Spurious Suppression: More than 60 dB

Antenna Impedance: 50 ohms, unbalanced

★ Specifications subject to change without notice.



Cobra Communications Product Group

DYNASCAN CORPORATION

6460 W. Cortland Street

Chicago, Illinois 60635

CONTENTS

	Page
DIMENSIONS AND LOCATION OF CONTROLS . . .	1
FEATURES	1
SERVICING NOTICES	2
ANTENNA TRIMMER ALIGNMENT	2
CONNECTIONS DIAGRAM	2
PARTS LOCATION	3
DISASSEMBLY INSTRUCTIONS	4, 5
SCHEMATIC DIAGRAM	6
WIRING DIAGRAM	7
ALIGNMENT INSTRUCTIONS	8~11
P.C. BOARDS WIRING DIAGRAM	12, 13
HOW TO REMOVE P.C. BOARDS	14, 15
ALIGNMENT CONNECTIONS	16
IC EQUIVALENT CIRCUITS	16, 17
FUNCTIONAL BLOCK DIAGRAM	18
BLOCK DIAGRAM OF P.L.L.	19
CIRCUIT DESCRIPTION	19~21
NORMAL CARE AND MAINTENANCE	22
INSTALLATION INSTRUCTIONS	22
CB ANTENNA SYSTEM	23
TROUBLE SHOOTING GUIDE	24, 25
EXPLODED VIEW	26, 27
REPLACEMENT PARTS LIST	28

FEATURES

- In-dash 40 channel CB mobile transceiver with AM/FM-MPX stereo radio.
- Adjustable shaft spacing.
- DC 12V, Negative ground.
- For in-dash installation.

[RADIO SECTION]

- Sensitive superheterodyne system with IC's and ceramic filters.
- A.F.C. (Automatic Frequency Control) for FM reception.
- A.G.C. (Automatic Gain Control) for AM reception.
- DX/LOCAL Switch for FM reception.

[CB TRANSCEIVER SECTION]

- Double-conversion superheterodyne system receiver.
- P.L.L. (Phase Locked Loop) synthesized 40 channel selection.
- A.N.L. (Automatic Noise Limiter)
- Variable squelch control.
- Over-modulation protection circuit.
- S/RF Meter.
- CB monitoring reception.
- Coaxial type antenna connector.
- Press-to-talk switch with microphone.
- A.G.C. (Automatic Gain Control).

DIMENSIONS AND LOCATION OF CONTROLS

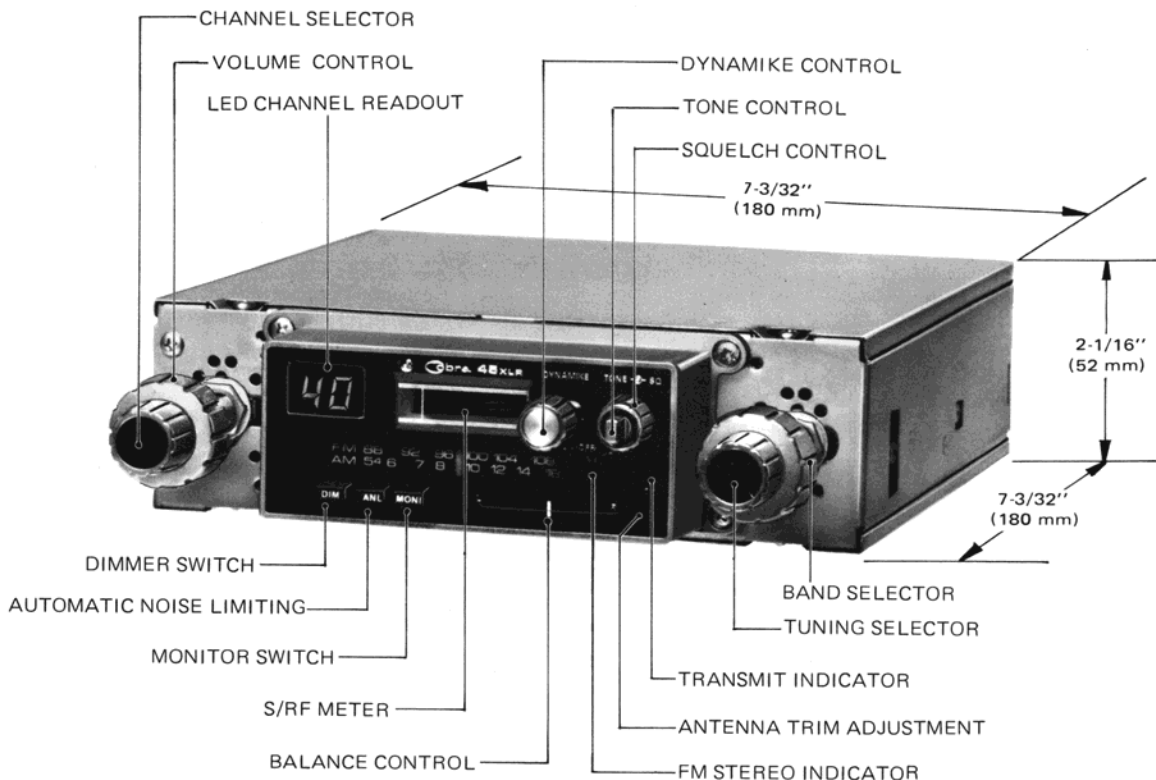

- Shaft Spacing: 5-5/8" (143 mm) ~ 6-5/16"(160 mm)

Seating hole number	Shaft spacing dimension
2	5-5/8" (143 mm)
3	5-13/16" (148 mm)
4	6" (152 mm)
5	6-5/16" (160 mm)

ANTENNA TRIMMER ALIGNMENT

The antenna trimmer alignment can be made without removing any parts.

To adjust the antenna trimmer CV51, tune in a weak station near 1400 kHz.

Insert a small screwdriver through the escutcheon as shown below, and turn clockwise or counterclockwise for maximum output.

SERVICING NOTICES

In U.S.A.

FCC Rules and Regulations, Part 95, require that only those persons possessing a valid First or Second Class Radio Telephone Operator's License are permitted to make repairs or adjustments in the transmitter section of a citizens band transceiver.

In CANADA

Please consult General Radio Service Handbook from Department of Communication or Information Canada.

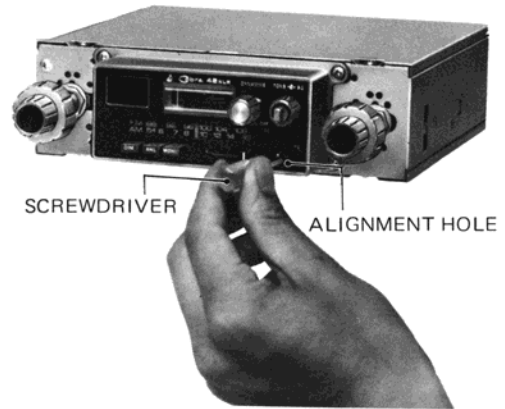

CONNECTIONS DIAGRAM

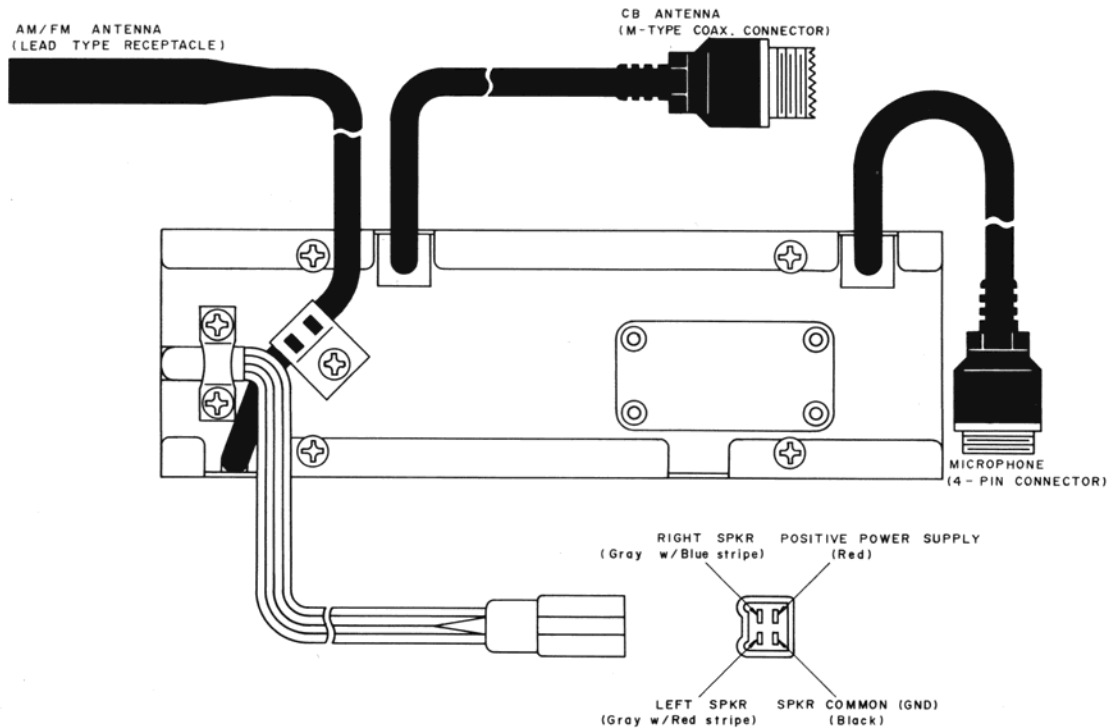

PARTS LOCATION

- Numbers in () are indicated REF. NO. in the REPLACEMENT PART LIST.
- Refer to EXPLODED VIEW in page 26, 27.

TOP VIEW, WITH COVER REMOVED

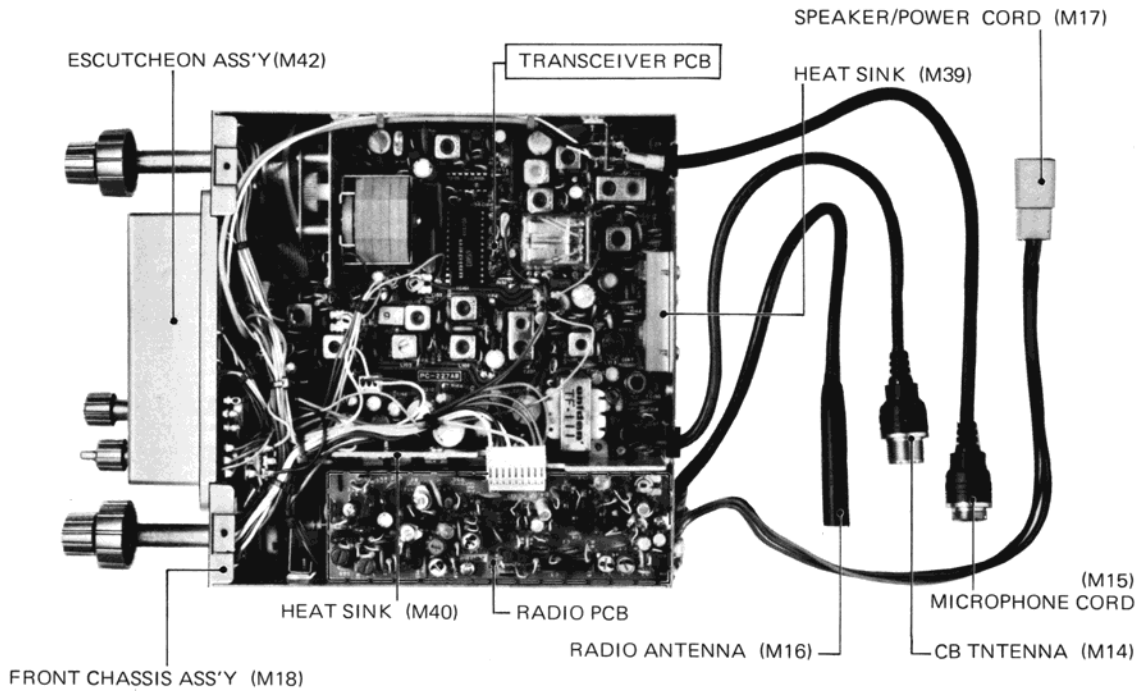

BOTTOM VIEW, WITH COVER REMOVED

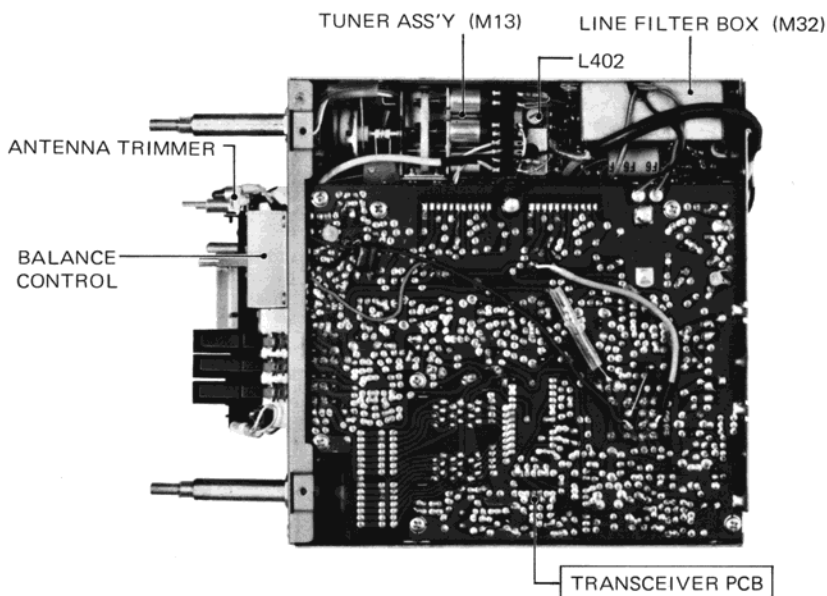

DISASSEMBLY INSTRUCTION

ESCUTCHEON ASS'Y

- The escutcheon ass'y can be taken off by removing four screws, after pulling out the knobs.

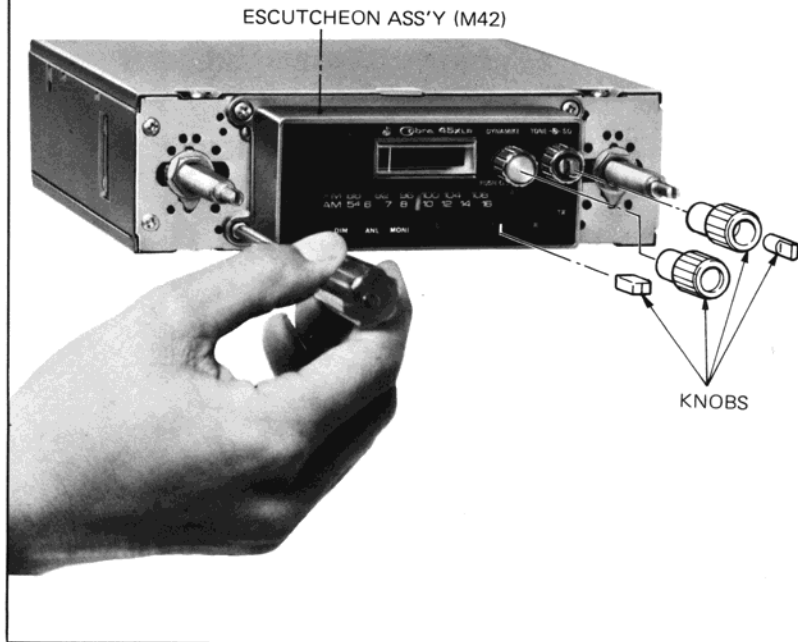

TOP COVER

- The top cover can be taken off by removing four screws.

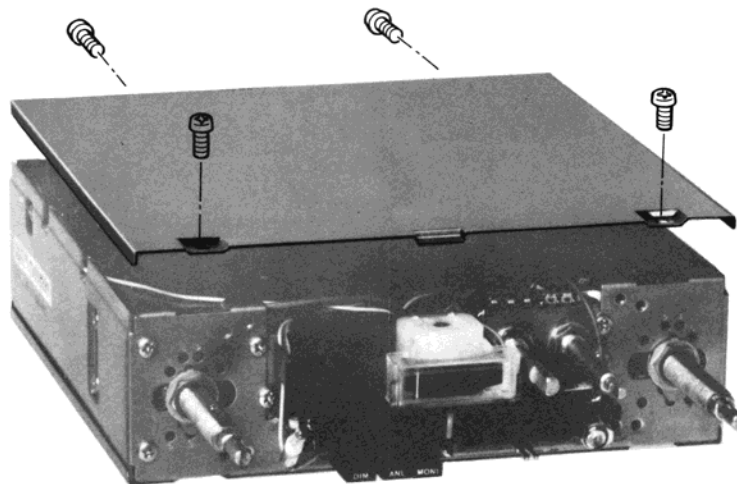

BOTTOM COVER

- The bottom cover can be taken off by removing four screws.

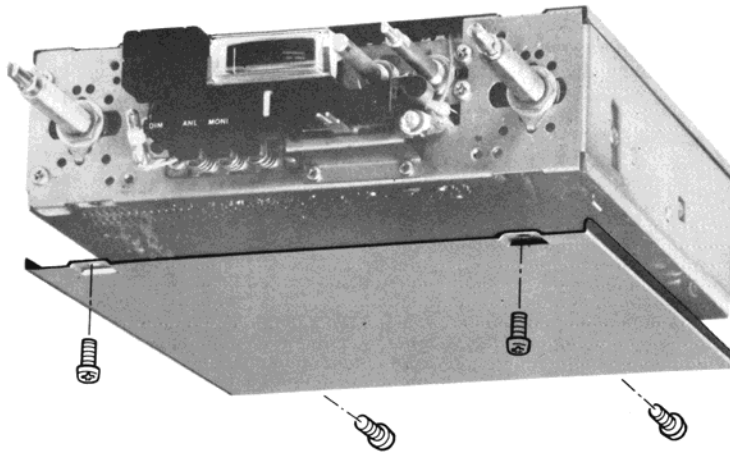

ALIGNMENT PROCEDURES (RADIO SECTION)

■ MEASURING INSTRUMENTS REQUIRED

- Signal Generator: AM 450~1700 kHz, 400 Hz, 30% modulation.
FM 10.7 MHz, 86~110 MHz, 400 Hz, 22.5 kHz deviation.
- Sweep Generator: 10.7 MHz
- Frequency Counter: Must be able to measure 19 kHz.
- Dummy Antenna: Refer to Fig. 1 and Fig. 2
- Test Probe: Refer to Fig. 6
- Indicator: Output meter (AC voltmeter or VTVM)
CRT Oscilloscope
- Specified Power Source Voltage: DC 13.8V

AM (IF & RF) ALIGNMENT

- Set VOLUME Control at maximum, and TONE control in the maximum treble position.
- Set BAND Selector switch in AM.
- Set BALANCE Control in its midway position.
- Set ST-BY Switch in OFF position.
- Connect the signal generator to the radio antenna receptacle through the antenna pad. (Fig. 1)
- Keep the signal generator output low enough to prevent overloading the circuit.

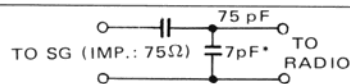

* Including the feeder stray capacitance.

Fig. 1 Antenna Pad for AM

STEP	GENERATOR FREQUENCY	DIAL SETTING	INDICATOR CONNECTION	ADJUST	REMARKS
1~4	455 kHz	Low frequency end stop.	Output meter across 4 ohm load.	L5 (yellow) L6 (white) L7 (green) L8 (green)	Adjust for maximum.
5	505 kHz	Low frequency end stop.	''	L3 (red)	''
6	1650 kHz	High frequency end stop.	''	CV53	''
7 8	1400 kHz	Tune to signal.	''	CV52 CV51	''
9	Repeat steps 5 and 6 until no further increase.				
NOTE: After the radio is installed in car, and antenna extended to desired height, tune in a weak station around 1400 kHz and adjust antenna trimmer (CV51) for maximum output.					

FM IF ALIGNMENT USING SWEEP GENERATOR

- Set BAND Selector switch in FM.
- Set VOLUME Control at minimum, and TONE Control in the maximum treble position.
- Connect the Sweep generator to the radio antenna receptacle through the antenna pad. (Fig. 2)

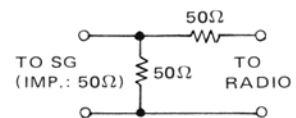
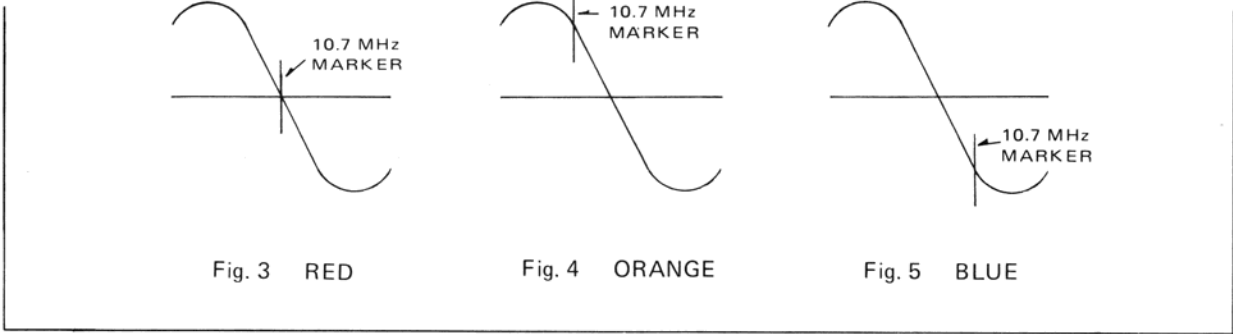

Fig. 2 Antenna Pad for FM

STEP	GENERATOR FREQUENCY	DIAL SETTING	INDICATOR CONNECTION	ADJUST	REMARKS
10~12	10.7 MHz (Sweep)	Point of non-interference	Vert. amp. of oscilloscope between test point TP6 and ground.	*L402 (orange) on Front-od L1 (blue) L2 (pink)	Adjust for maximum amplitude and proper linearity. (Refer Note & Fig. 3)
13	Repeat steps 10 to 12 several times.				
*See 'BOTTOM VIEW' page 2					

- NOTE: 1. FM Sweep Generator should be definitely required for FM IF Alignment, because ceramic filters are used in IF circuit. 3 kinds of ceramic filters are used and they are different in their center frequencies as shown below:
2. If the ceramic filters except red colored are used, 10.7 MHz marker will not appear at the center of "S" curve (See Fig. 4 or 5). In these cases, disregard 10.7 MHz marker.
 3. The color-code of ceramic filters used is different according to the production lots, but the same color-coded ceramic filters should be replaced as one pair on the individual units.



FM RF ALIGNMENT

- Adjustable components for FM RF Alignment are located under tuner coils, therefore it is impossible to align FM RF section without disassemble FM front-end tuner printed circuit board from the tuner assembly. Replace whole tuner assembly instead of FM RF alignment.

MULTIPLEX ALIGNMENT

- Set BAND Selector switch in FM.
- Connect Frequency Counter between the test point TP7 and the ground through the test probe. (Fig. 6)
- Adjust RV1 to obtain 19.20 kHz indication on the frequency counter.

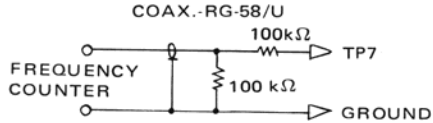
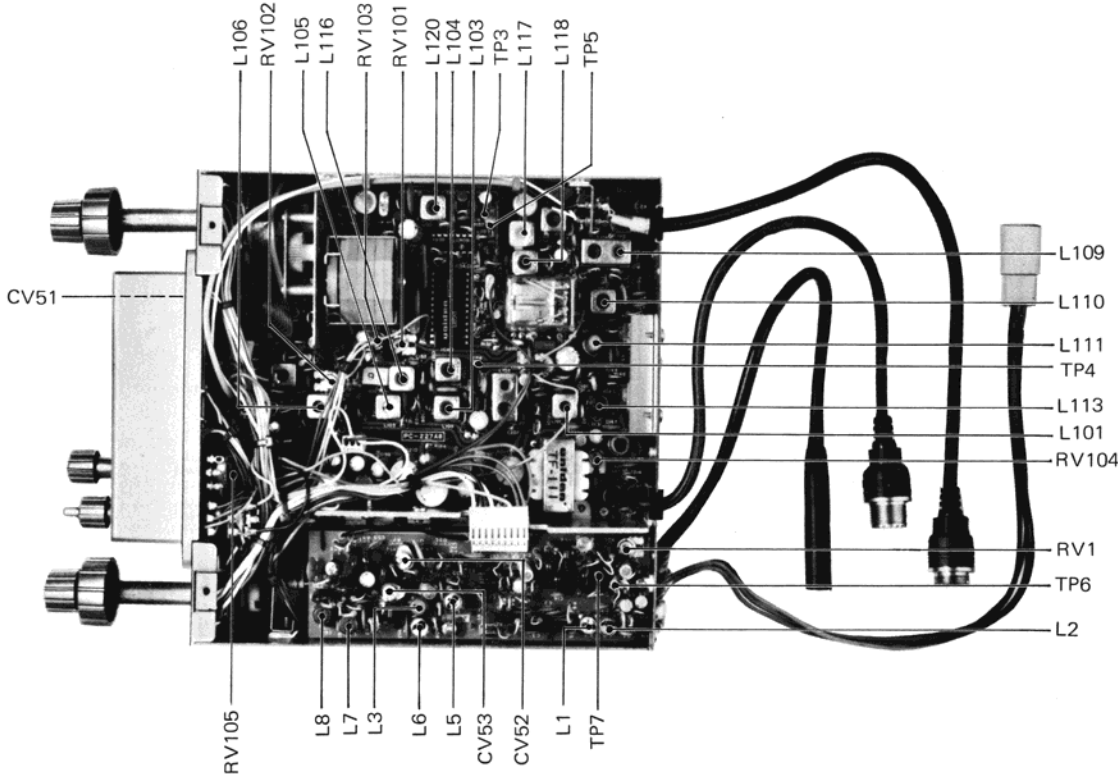

Fig. 6



ALIGNMENT PROCEDURES (CB TRANSCEIVER SECTION)

■ MEASURING INSTRUMENTS REQUIRED

- Frequency Counter: Must be able to determine transmitter frequency of each channel within 0.005% accuracy.
- Signal Generator: AM 26.960~27.410 MHz, 1000 Hz, 30% modulation.
- Audio Generator: 1000 Hz, including attenuator.
- Dummy Load: Refer to Fig. 7 and Fig. 8
- Indicator:
 - RF Wattmeter (5W, 50Ω, 27 MHz)
 - DC Voltmeter
 - AF Output Meter (AC Voltmeter or VTVM)
 - Oscilloscope
 - RF Voltmeter
- Specified Power Source Voltage: DC 13.8V

OSCILLATOR ALIGNMENT

<ul style="list-style-type: none"> • Set BAND Selector switch in CB. • Set CHANNEL Selector switch to Channel 19. 			
STEP	INDICATOR CONNECTION	ADJUST	REMARKS
1	RF Voltmeter between test point TP3 and ground.	L120	Adjust to 90% position of the maximum indication by rotating slug core counter clockwise from the maximum position.
2	DC Voltmeter between test point TP5 and ground.	L117	Adjust for 2.5V ± 0V indication.
3	RF Voltmeter between test point TP4 and ground.	L118	Adjust for maximum. Indication should be $1V_{p-p} \pm 0.3V_{p-p}$.

TRANSMITTER ALIGNMENT

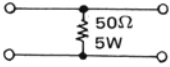
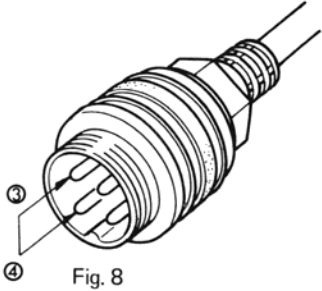
<ul style="list-style-type: none"> • Set BAND Selector switch in CB. • Set CHANNEL Selector switch to Channel 19. • Short terminals ③ and ④ on the MICROPHONE CONNECTOR (Refer to Fig. 8). • Connect the dummy load (Fig. 7) to the CB ANTENNA Connector. 			
			
			
STEP	INDICATOR CONNECTION	ADJUST	REMARKS
4	RF output meter across dummy load.	L109	Adjust for maximum.
5		L110	
6		L111	
7		L113	
8	Repeat steps 4 thru 7 until no further increase.		
9	If the output power becomes in excess of FCC Regulation (4W), decrease the output power by rotating clockwise the slug of L113.		
10	Frequency counter across dummy load thru proper attenuator.	L120	Adjust for correct transmitting frequency.
11	Check the transmitting frequency deviations on all channels.		
12	Built-in RF meter.	RV104	Adjust for proper indication. (between 3.5 and 4)

MODULATION LIMITER ALIGNMENT

- Set BAND Selector switch in CB.
- Set CHANNEL Selector switch to Channel 19.
- Connect the dummy load (Fig. 7) to the CB ANTENNA Connector.
- Connect the audio signal generator to terminals ① and ② on the MICROPHONE connector thru the 600Ω pad. (Refer to Fig. 9 and Fig. 10)
- Short terminals ③ and ④ on the MICROPHONE connector. (Refer to Fig. 10)
- Connect the AF Voltmeter across the 600Ω pad.

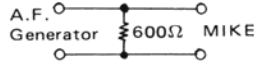

Fig. 9 600Ω Pad

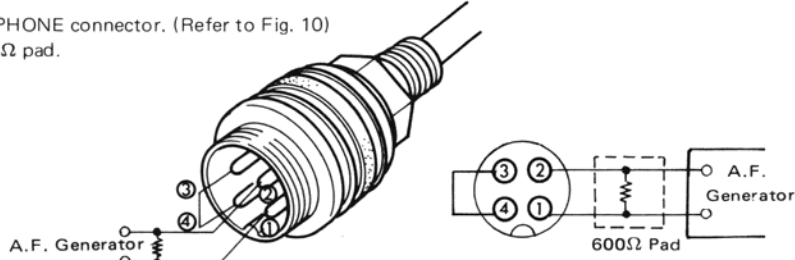

Fig. 10 MIKE CONNECTOR Connection

STEP	INDICATOR CONNECTION	ADJUST	REMARKS
13	Oscilloscope across dummy load thru proper attenuator.	RV105	Adjust for around 90% modulation

RECEIVER ALIGNMENT

- Set BAND Selector switch in CB.
- Set CHANNEL Selector switch to Channel 19.
- Do not connect MICROPHONE or any wire to the MICROPHONE connector.
- Connect the signal generator to the CB ANTENNA Connector with 1000 Hz, 30% modulation.
- Set VOLUME Control for 0.5W audio output.
- Set SQUELCH Control in the fully counter-clockwise position.
- Set TONE Control in the maximum treble position.
- Set BALANCE Control in its midway position.
- Set ANL Switch in OFF position.
- Connect 4Ω dummy load between right speaker output lead and ground.

STEP	GENERATOR FREQUENCY	INDICATOR CONNECTION	ADJUST	REMARKS
14 15 16 17 18 19	CH 19 (27.185 MHz)	AF Output meter across dummy load.	L101 L103 L104 L105 L116 L106	Ajust for maximum.
20	Set RF input level to 0.35 μV. Set VOLUME Control in the maximum position.	Ditto.	RV101	Adjust for 0.5W audio output.
21	Set RF input level to 300 μV. Set VOLUME Control in the maximum position. Set SQUELCH Control in the fully clockwise position.	Ditto.	RV103	Ditto.
22	Set RF input level to 100 μV.	Built-in S-meter.	RV102	Adjust for S-9 indication.

ALIGNMENT CONNECTIONS

FOR RADIO SECTION

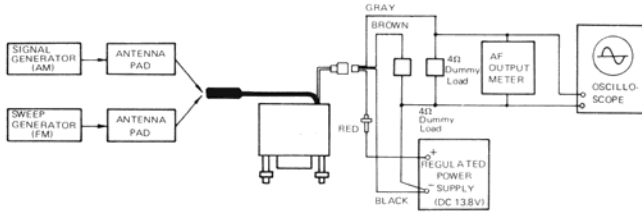

FOR CB TRANSMITTER SECTION

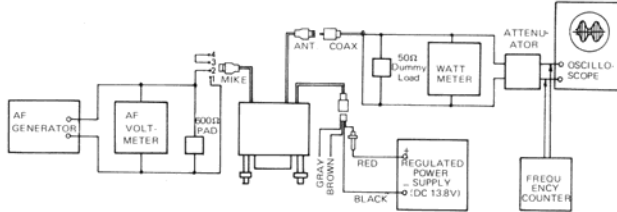

FOR CB RECEIVER SECTION

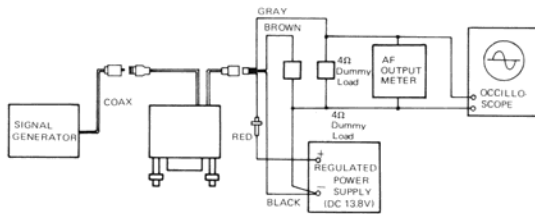

IC EQUIVALENT CIRCUITS

IC1 μ PC577H

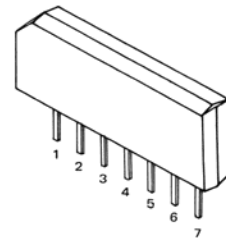
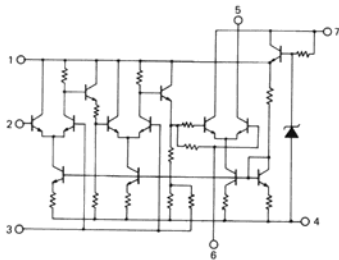

IC2 KB4409

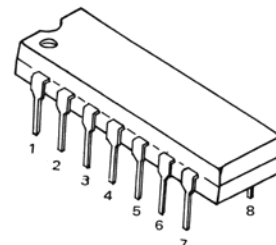
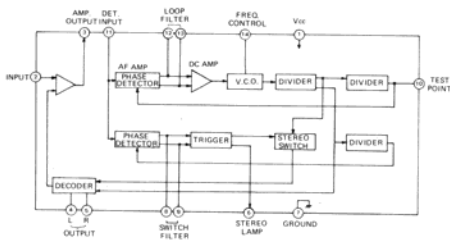

IC2
IC102

IC102 MB84011

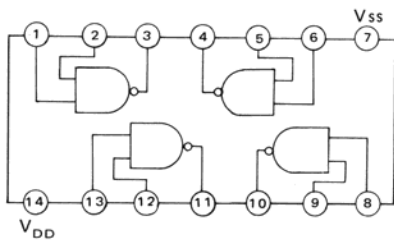

BLOCK DIAGRAM OF P.L.L.

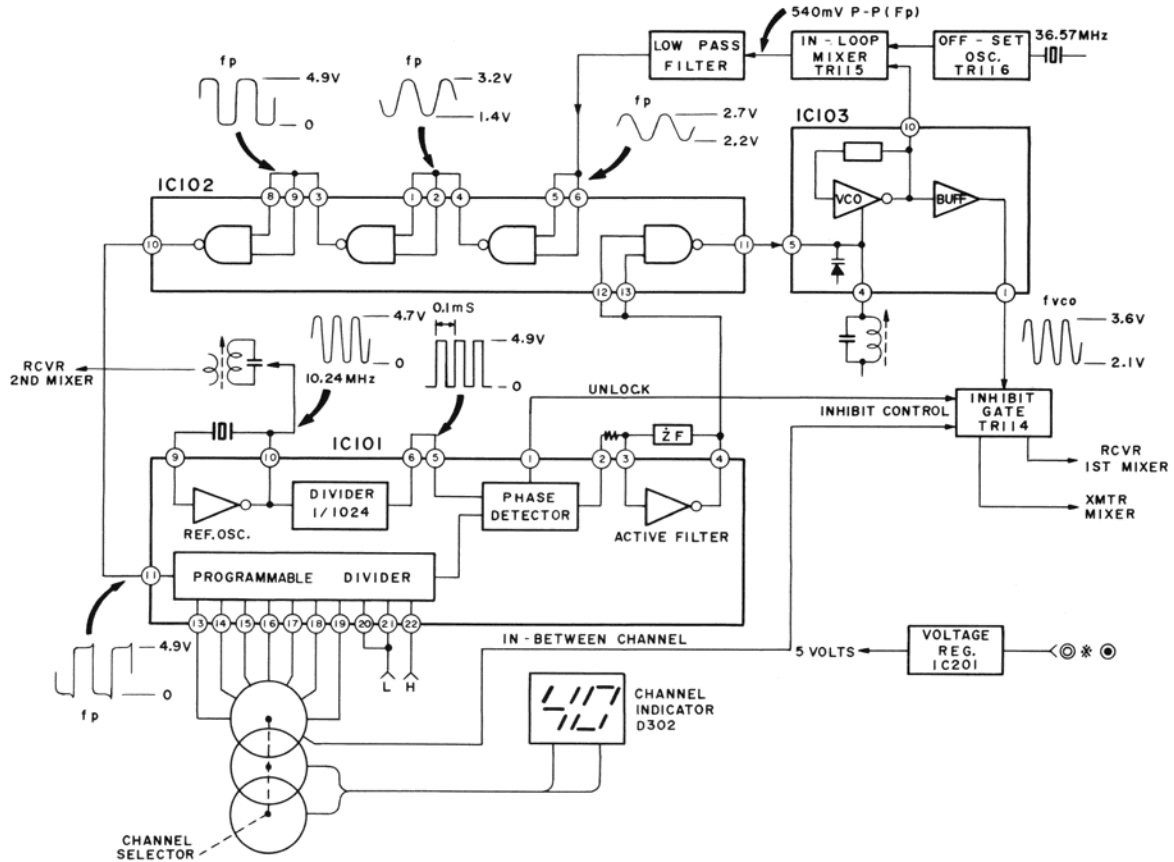

CIRCUIT DESCRIPTION

CIRCUIT FOR DETERMINING FREQUENCY OF CB TRANSCEIVER

1. Receiving Frequency (Refer to FUNCTIONAL BLOCK DIAGRAM)

Received signal is amplified by RF Amplifier TR101 (2SC1047) and is applied to the gate of Receiver 1st Mixer TR102 (2SK55).

1st local oscillator frequency, F_{vco} , which is produced by the P.L.L. Local Oscillator circuit is applied to the source of TR102.

The difference of these frequencies makes the 1st intermediate frequency of 10.695 MHz as follows;

$$F_{vco} - F_r = 10.695 \text{ (MHz)}$$

F_r : Frequency of received signal.

The difference between the 1st i.f. of 10.695 MHz and the 2nd local frequency of 10.24 MHz produced by IC101 (μ PD858C) makes the 2nd intermediate frequency of 455 kHz.

2. Transmitting Frequency (Refer to FUNCTIONAL BLOCK DIAGRAM)

Transmitting frequency, F_t is the output of the Transmitter Mixer TR110 (3SK45).

One of the input signals of TR110 is the 1st local frequency, F_{vco} , which is produced by the P.L.L. Local Oscillator circuit, and the other is the transmitter local frequency of 10.695 MHz produced by TR109 (2SC829).

The difference of these frequencies makes the transmitting frequency as follows;

$$F_t = F_{vco} - 10.695 \text{ (MHz)}$$

3. **Transmitter Local Frequency** (Refer to FUNCTIONAL BLOCK DIAGRAM)

Transmitter local frequency of 10.695 MHz is produced by the Transmitter Oscillator TR109 (2SC829) and the output frequency is determined by the quartz crystal X1.

4. **P.L.L. Local Oscillator** (Refer to BLOCK DIAGRAM of P.L.L.)

Fvco, the output frequency of the VCO (or Voltage Controlled Oscillator) IC103 (UHIC-004), is fed into one of the input terminals of the In-loop Mixer TR115 (3SK45).

Fos, the output frequency of the Off-set Oscillator, TR116 (2SC829), of which frequency is 36.570 MHz, is fed into the another input terminal of TR115.

These frequencies are mixed by TR115 and the difference between **Fvco** and **Fos** makes the input frequency to the Programmable Frequency Divider.

The input frequency to the Programmable Divider, **Fp**, is calculated as follows;

$$Fp = Fvco - Fos \text{ (36.570 MHz)}$$

Fp is then fed into the Programmable Divider in the P.L.L. IC, IC101 (μ PD858C) through the interface gates in IC102 (MB84011) and is divided by N by the Programmable Divider.

The frequency of 10.240 MHz produced by the Reference Frequency Oscillator in IC101 is divided by 1024 by the Reference Frequency Divider in IC101 and resultant frequency, **Fref** is:

$$Fref = 10.240 \text{ MHz} \div 1024 = 10 \text{ kHz}$$

The output frequency of the Programmable Divider is compared with **Fref** in the Phase Detector in IC101, in other words, these frequencies are phase detected by the Phase Detector, and **Fp** divided by N becomes equal to **Fref** (10 kHz) when the phase locked loop is under locked condition.

Therefore, **Fvco** is determined by the following formula, relating **Fos** and the divide ratio N.

$$Fvco = Fos \text{ (36.570 MHz)} + 10 \times N \text{ (kHz)}$$

Fvco is changeable at the increment of 10 kHz by varying the program divide ratio, N.

For example, the divide ratio, N is programmed to 109 at the channel No. 1, therefore **Fvco** is calculated as follows:

$$\begin{aligned} Fvco &= 36570 + 10 \times 109 = 36570 + 1090 \\ &= 37660 \text{ (kHz)} \end{aligned}$$

In the same manner, **Fvco** for channel No. 1 through No. 40 is determined as shown in Table 1.

5. **Channel Selection Program** (Refer Table 1)

The divide ratio of the Programmable Frequency Divider in IC101 is determined by supplied voltages to the program input terminals, Pin No. 13 through Pin No. 22 of the IC101.

The program input voltages for Pin No. 13 through Pin No. 19 are supplied from channel selector switch S1, and the inputs for Pin No. 20 and No. 22 are fixed to "LOW" level and the input for Pin No. 21 is fixed to "HIGH" level.

The function of the program input terminals is as follows;

Pin No.:	13	14	15	16	17	18	19	20	21	22
Function:	1A	1B	1C	1D	2A	2B	2C	2D	3A	3B
Significance Number:	1	2	4	8	10	20	40	80	100	200

*each program input effects when the input voltage is in "HIGH" level.

The divide ratio, N of the Programmable Divider is given by the sum of the significance numbers which are effective by supplying "HIGH" level input. For example, when channel selector switch is set to channel No. 1, the input levels of 1A, 1D and 3A are in "HIGH" level, and the input levels of other terminals are in "LOW" level, therefore, divide ratio, N is determined as follows;

$$N = 1 + 8 + 100 = 109$$

In the same manner, divide ratio, N for channel No. 1 through No. 40 is determined as shown in Table 1.

TABLE 1. FREQUENCY & PROGRAM CHART

Channel Number	RCV or XMT Frequency	F _{vco}	F _p	Divide Ratio	Program Input Level									
					1A	1B	1C	1D	2A	2B	2C	2D	3A	3B
1	26.965	37.660	1.090	109	H	L	L	H	L	L	L	L	H	L
2	26.975	37.670	1.100	110	L	L	L	L	H	L	L	L	H	L
3	26.985	37.680	1.110	111	H	L	L	L	H	L	L	L	H	L
4	27.005	37.700	1.130	113	H	H	L	L	H	L	L	L	H	L
5	27.015	37.710	1.140	114	L	L	H	L	H	L	L	L	H	L
6	27.025	37.720	1.150	115	H	L	H	L	H	L	L	L	H	L
7	27.035	37.730	1.160	116	L	H	H	L	H	L	L	L	H	L
8	27.055	37.750	1.180	118	L	L	L	H	H	L	L	L	H	L
9	27.065	37.760	1.190	119	H	L	L	H	H	L	L	L	H	L
10	27.075	37.770	1.200	120	L	L	L	L	L	H	L	L	H	L
11	27.085	37.780	1.210	121	H	L	L	L	L	H	L	L	H	L
12	27.105	37.800	1.230	123	H	H	L	L	L	H	L	L	H	L
13	27.115	37.810	1.240	124	L	L	H	L	L	H	L	L	H	L
14	27.125	37.820	1.250	125	H	L	H	L	L	H	L	L	H	L
15	27.135	37.830	1.260	126	L	H	H	L	L	H	L	L	H	L
16	27.155	37.850	1.280	128	L	L	L	H	L	H	L	L	H	L
17	27.165	37.860	1.290	129	H	L	L	H	L	H	L	L	H	L
18	27.175	37.870	1.300	130	L	L	L	L	H	H	L	L	H	L
19	27.185	37.880	1.310	131	H	L	L	L	H	H	L	L	H	L
20	27.205	37.900	1.330	133	H	H	L	L	H	H	L	L	H	L
21	27.215	37.910	1.340	134	L	L	H	L	H	H	L	L	H	L
22	27.225	37.920	1.350	135	H	L	H	L	H	H	L	L	H	L
23	27.255	37.950	1.380	138	L	L	L	H	H	H	L	L	H	L
24	27.235	37.930	1.360	136	L	H	H	L	H	H	L	L	H	L
25	27.245	37.940	1.370	137	H	H	H	L	H	H	L	L	H	L
26	27.265	37.960	1.390	139	H	L	L	H	H	H	L	L	H	L
27	27.275	37.970	1.400	140	L	L	L	L	L	L	H	L	H	L
28	27.285	37.980	1.410	141	H	L	L	L	L	L	H	L	H	L
29	27.295	37.990	1.420	142	L	H	L	L	L	L	H	L	H	L
30	27.305	38.000	1.430	143	H	H	L	L	L	L	H	L	H	L
31	27.310	38.010	1.440	144	L	L	H	L	L	L	H	L	H	L
32	27.320	38.020	1.450	145	H	L	H	L	L	L	H	L	H	L
33	27.330	38.030	1.460	146	L	H	H	L	L	L	H	L	H	L
34	27.340	38.040	1.470	147	H	H	H	L	L	L	H	L	H	L
35	27.350	38.050	1.480	148	L	L	L	H	L	L	H	L	H	L
36	27.360	38.060	1.490	149	H	L	L	H	L	L	H	L	H	L
37	27.370	38.070	1.500	150	L	L	L	L	H	L	H	L	H	L
38	27.380	38.080	1.510	151	H	L	L	L	H	L	H	L	H	L
39	27.390	38.090	1.520	152	L	H	L	L	H	L	H	L	H	L
40	27.405	38.100	1.530	153	H	H	L	L	H	L	H	L	H	L

- 1: Frequencies are in MHz.
- 2: 1A is the least significant bit, and 3B is the most significant bit.
- 3: H means in "HIGH" level, and L means in "LOW" level.

NORMAL CARE AND MAINTENANCE

- Be sure to use a 3 A fuse for replacement. Use of a larger fuse may not protect the unit from excessive current drain.

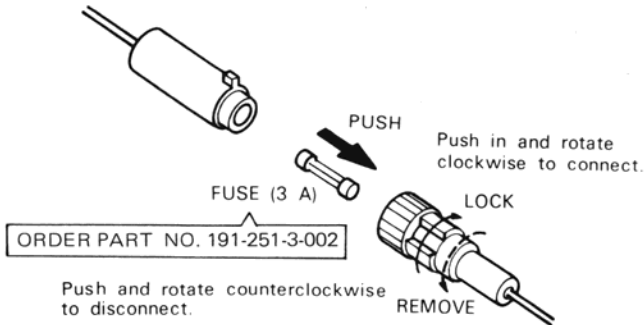

- The vehicle can be the cause of much noise interference. Since the receiver section of this set is very sensitive, it will pick up even the smallest noise signals and amplify them. Any noise that you hear in this set is almost totally from external sources. The receiver itself is exceptionally quiet. Steady high noise levels cannot be totally eliminated by the international Automatic Noise Limiter circuit. Noise problems cannot be solved internally (in the transceiver); they must be solved at the source of the noise. Several noise suppressor kits are available from local dealers which include all necessary parts and instructions.
- To clean the outside of the set (escutcheon and chassis) wipe off dust with a soft cloth. Never use benzene, thinner or any other type of solvent.

INSTALLATION INSTRUCTIONS

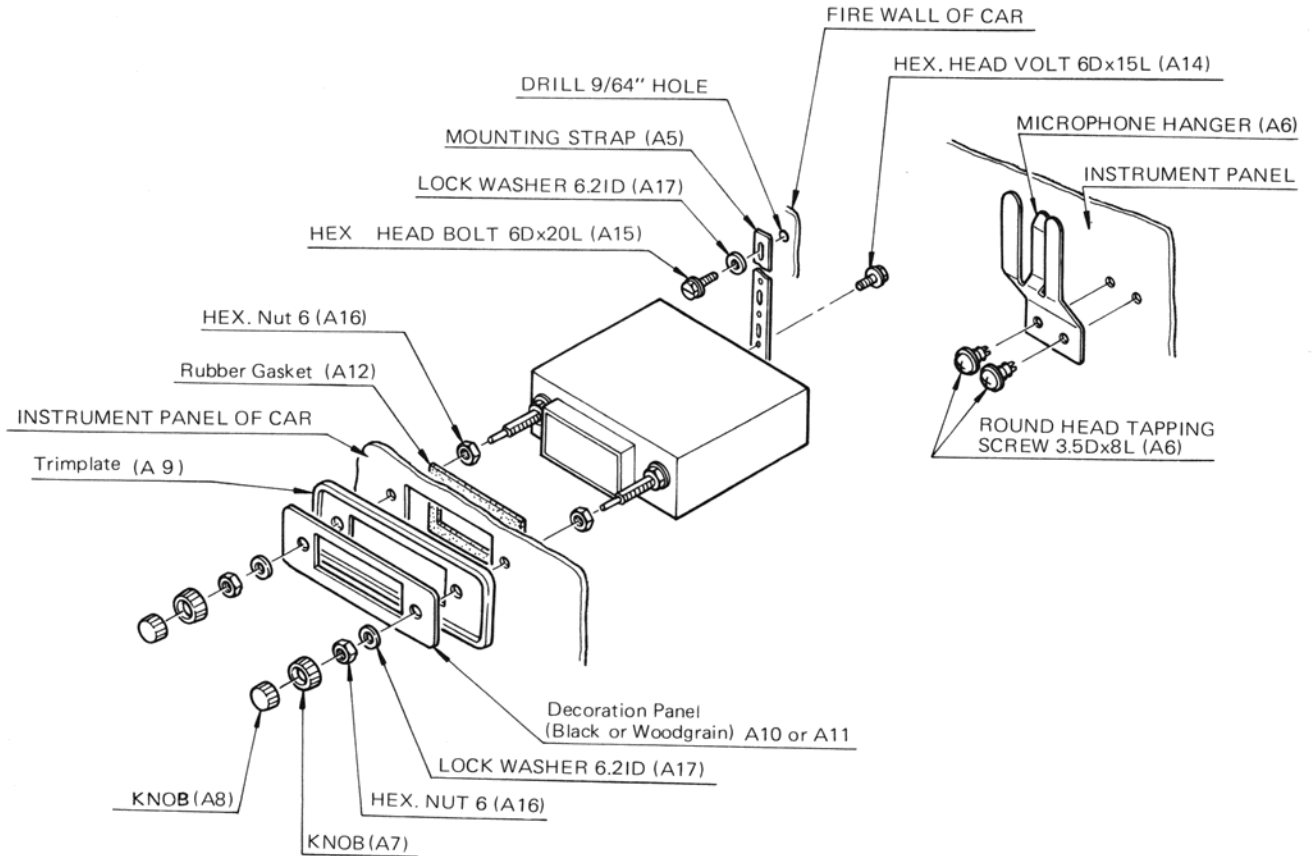

CB ANTENNA SYSTEM

It is very important that you use the correct type of transmission line. It should be of the coaxial type and should have an impedance equal to the antenna impedance.

Since the 45 XLR is designed to operate most efficiently into a 50Ω load, it is best to use a 50Ω coaxial cable. There are many different types of antennas designed for CB mobile use. Selection of one should be made on the basis of the type of installation, or car mount desired and the antenna specifications. A vertical whip normally has a 360° radiation pattern; and it can be mounted on the rear bumper, rear fender, or trunk lid.

Generally, it is better to mount the antenna on the left side of the car than on the right side, to minimize contact with trees and other low-clearance obstructions. Generally, the better the antenna, the better the communications over greater distances. A full $1/4$ wavelength antenna is usually more efficient than the shorter versions equipped with a loading coil to electrically make up for the shorter length. However, the antennas can provide adequate service, and be less prone to damage from contact with external obstructions. Some short antennas can be more centrally located on the car. The car body acts as a ground plane and tends to shift the radiation pattern to favor a diagonal line, running from the right front of the car to the left rear, for an antenna mounted on the right front or left rear portion of the car. For an antenna mounted on the left front or right rear portion of the car, the pattern will follow the diagonal line from the left front to the right rear of the car. For a more circular pattern, the antenna would have to be centrally mounted on the car. Effective antenna height, clearance and directional characteristics are affected by terrain, buildings, tunnels, bridges, etc. Generally, the fewer the obstructions and the higher the ground level, the greater the range of communications.

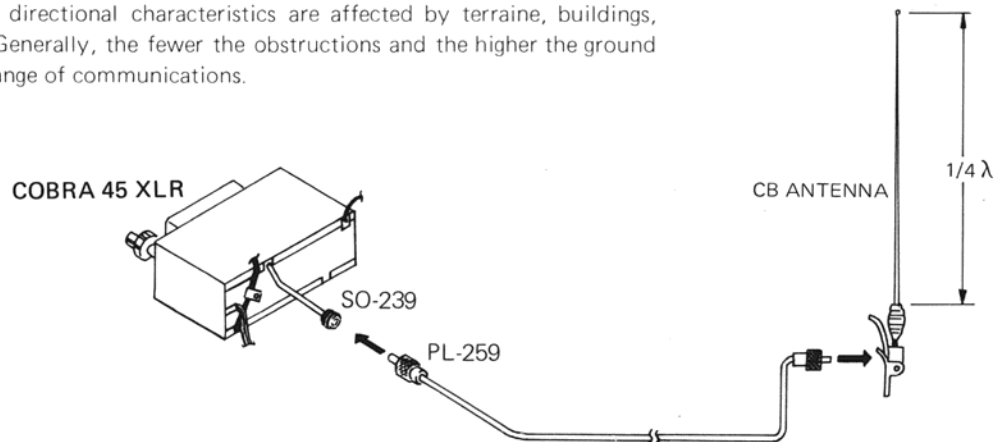

TROUBLE SHOOTING GUIDE FOR CB TRANSCEIVER SECTION

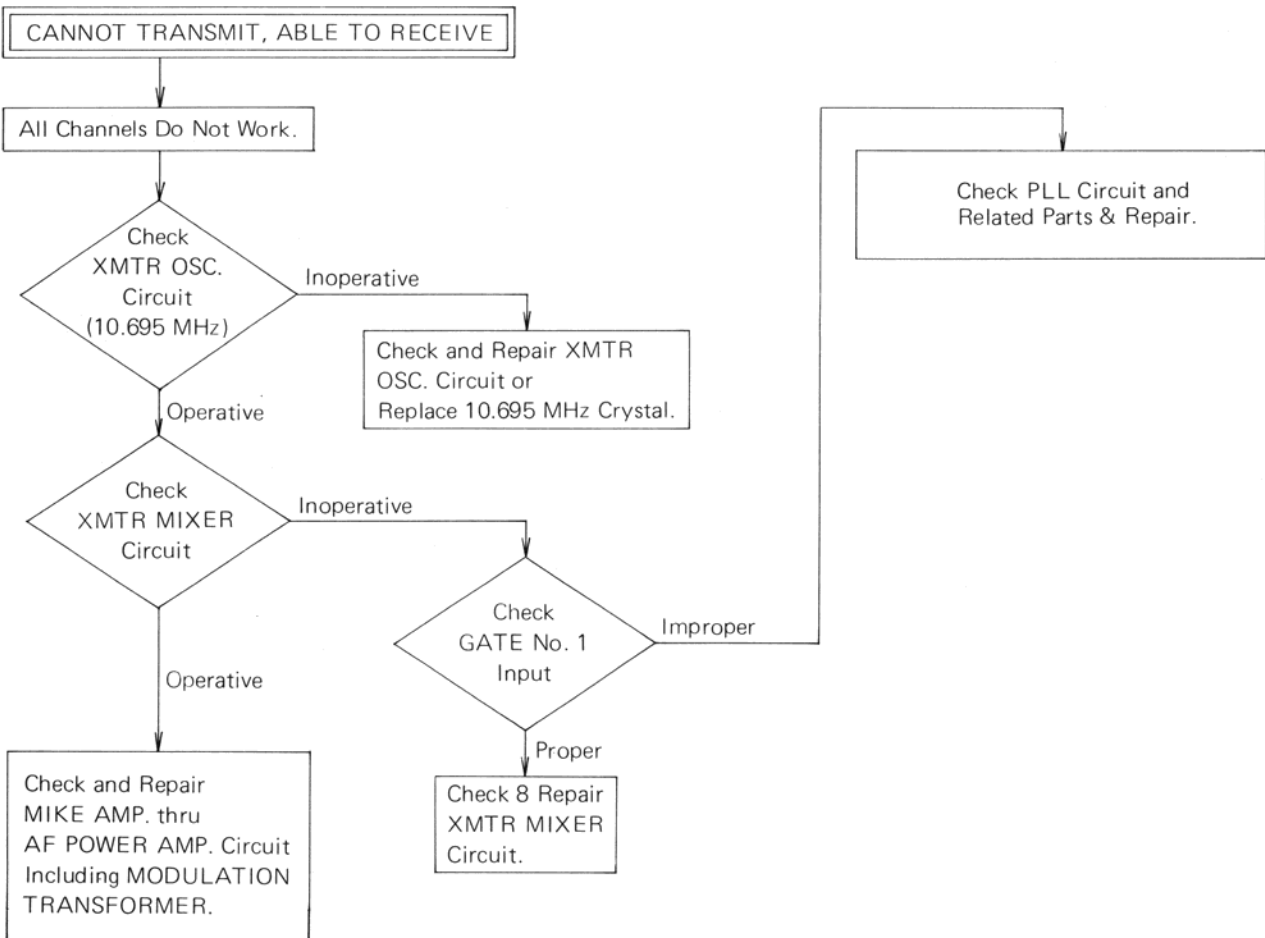
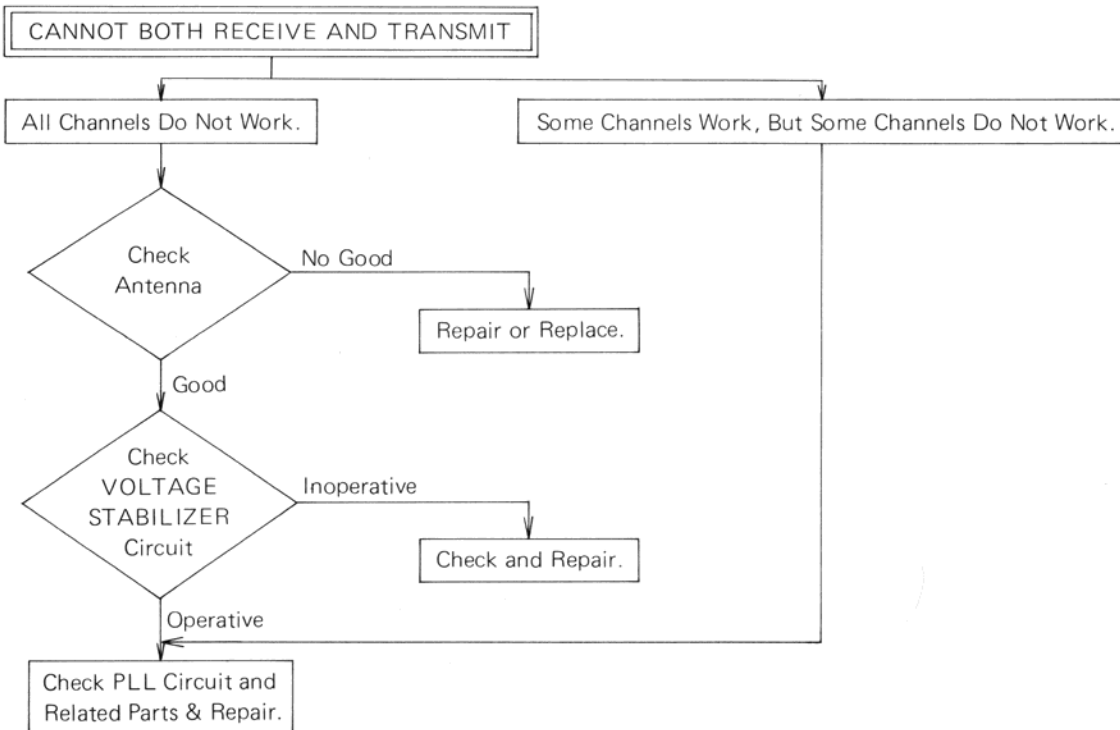

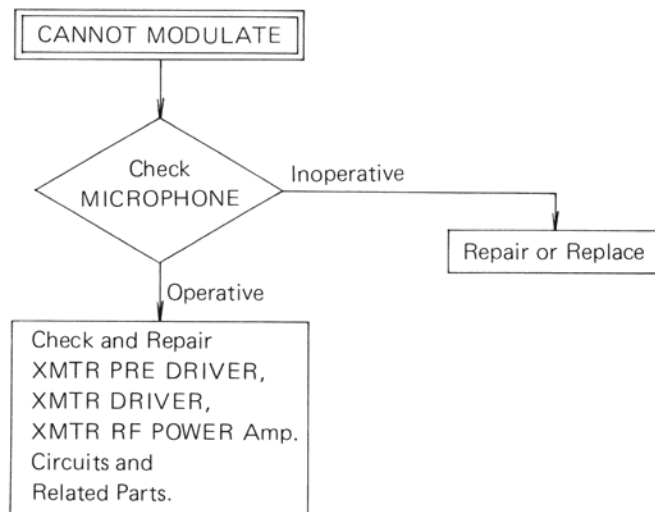
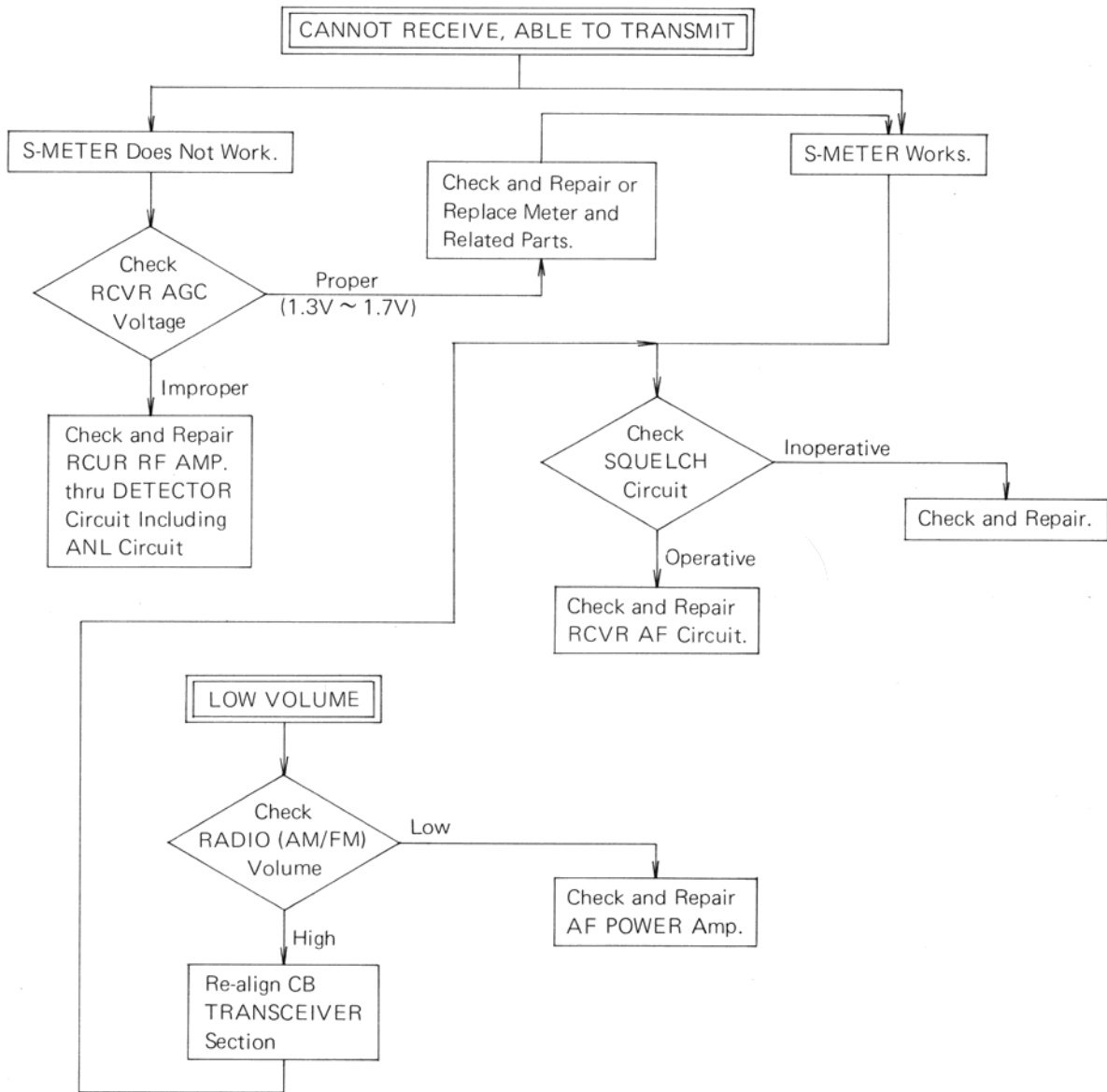

Replacement Parts List
For COBRA 45XLR

CIRCUIT SYMBOL	DESCRIPTION	PART NO.
COILS		
L-101	LA-029	066-023-9-001
L-105	LA-163	060-022-9-001
L-103	LA-180	060-024-9-001
L-104	LA-181	060-024-9-002
L-116	LA-182	060-024-9-003
L-106	LA-183	060-024-9-004
L-107	LA-184	060-024-9-005
L-109	LA-185	060-024-9-006
L-120	LA-186	060-024-9-007
L-117	LA-187	060-024-9-008
L-118	LA-188	060-024-9-009
L-110	LA-189	060-024-9-010
L-108	LA-193	060-024-9-011
L-102	LA-194	060-024-9-012
L-1	LB-084	046-019-9-001
L-2	LB-085	046-019-9-002
L-8,7	LB-086	046-019-9-003
L-6	LB-087	046-019-9-004
L-3	LB-088	046-019-9-005
L-5	LB-089	046-019-9-006
L-111	LB-017	044-047-9-001
L-113	LB-020	044-047-9-002
L-114	LC-110	041-078-9-001
L-115	LE-064	041-093-9-001
L-112	LD-012	044-028-9-003
L-10	LD-081	041-093-9-002
L-11	LD-075	041-093-9-003
INDUCTORS		
L-4	LZ-002 4.7μH	041-093-9-004
L-121	LZ-002 1μH	041-056-9-002
L-119	LZ-002 100μH	041-087-9-002
L-124	LZ-015 47mH	041-093-9-005
L-123	LZ-015 68mH	041-086-9-004
L-	NOISE SUP. COIL	042-026-9-001
TRANSFORMERS		
CH-301	Choke Trans.	042-014-9-001
T-1	Output Trans.	061-035-9-001

CIRCUIT SYMBOL	DESCRIPTION	PART NO.
INTEGRATED CIRCUIT'S		
IC-101	μPD858C	307-095-9-004
IC-102	MB84011μ	307-113-9-001
IC-103	UHIC-004	307-113-9-002
IC-201	NJM78L05A	307-113-9-002
IC-105,104	AN-315 Audio Power	307-120-9-001
IC-1	μPC-577-H	307-115-9-001
IC-2	KB-4409 Stereo Multipler Decoder	307-120-9-002
FET'S		
TR-102	2SK55-D	182-045-9-001
TR-110,115	3SK45-B	182-038-9-001
TRANSISTORS		
TR-101	2SC1047-C NPN, Silicon Signal	150-014-9-001
TR-51,52,53,103,105	2SC829-B NPN, Silicon Signal	150-006-9-001
TR-1,2,104,109,116	2SC829-C NPN, Silicon Signal	176-075-9-003
TR-106,107,108	2SC828-Q NPN, Silicon Signal	176-075-9-004
TR-114,118,119,120	2SC828-R NPN, Silicon Signal	176-075-9-005
TR-111	2SC2076-CB NPN, Silicon Signal	176-060-9-004
TR-112	2SC-1846-Q NPN, Silicon Signal	176-075-9-006
TR-113	2SC1975 NPN, Silicon Signal	176-075-9-007
TR-201,202	2SC1846-P NPN, Silicon Signal	176-075-9-008
TR-117	2SA564-Q PNP, Silicon Signal	177-027-9-001
DIODES		
D-104,105,107,53,54	Forming D, 1N60 AM Diode	150-014-9-001
D-1,2	Forming D, 1N60 P Diode	150-006-9-001
D-51,52,101,102,103,203,204,206	Diode, 1S2076 Silicon	150-067-9-001
D-106,108,109	Forming D, 1S2473K	151-069-9-001
D-205,301	Diode, SRIK-1	151-040-9-003
D-202	Zener Diode, CZ-092	152-051-9-001
D-302	LED TLR-321 Channel Display	158-014-9-001
D-303	LED LR0702R Transmit LED	151-064-9-003
D-304	LED LN25D Stereo LED	158-016-9-001

CIRCUIT SYMBOL	DESCRIPTION	PART NO.
VARIABLE RESISTORS		
VR-101,105	Semi Fixed Resistor RV189 100K B	008-316-9-001
VR-103,104	Semi Fixed Resistor, RV189 50K B	008-316-9-002
VR-102	Semi Fixed Resistor, RV188 20K B	008-316-9-003
VR-1	Semi Fixed Resistor, RV189 5K B	008-316-9-004
VR-3	Variable Resistor, RV198	008-316-9-005
VR-5,S-3	Variable Resistor, RV199	008-316-9-006
VR-4	Variable Resistor, RV200	008-316-9-007
VR-2	Variable Resistor, RV201	008-316-9-008
RESISTORS		
R-51	Carbon Resistor, 10KΩ ½W J	002-108-5-103
R-71	Carbon Resistor, 470KΩ ¼W J	002-108-5-471
R-145	Carbon Resistor, 1Ω ¼W J	002-104-5-010
R-144	Carbon Resistor, 2.2Ω ¼W J	002-104-5-229
R-164	Carbon Resistor, 10Ω ¼W J	002-104-5-100
R-114,182,185	Carbon Resistor, 68Ω ¼W J	002-104-5-680
R-142,146,8	Carbon Resistor, 47Ω ¼W J	002-104-5-470
R-143,120,204,6,139 166,191	Carbon Resistor, 100Ω ¼W J	002-104-5-101
R-1,53,58,104,107,110,116	Carbon Resistor, 220Ω ¼W J	002-104-5-221
R-3,101,136,171	Carbon Resistor, 330Ω ¼W J	002-104-5-331
R-5,57,59,62,63,187,171	Carbon Resistor, 470Ω ¼W J	002-104-5-471
R-119,160,173,180	Carbon Resistor, 680Ω ¼W J	002-104-5-681
R-106,109,188	Carbon Resistor, 820Ω ¼W J	002-104-5-821
R-4,9,10,16,19,21,22,23 24,54,103,105,115, 150,162,167	Carbon Resistor, 1KΩ ¼W J	002-104-5-102
R-166	Carbon Resistor, 1.5KΩ ¼W J	002-104-5-152
R-111,161,172,66,181,184	Carbon Resistor, 2.2KΩ ¼W J	002-104-5-222
R-57,140	Carbon Resistor, 2.7KΩ ¼W J	002-104-5-272
R-108,113,117,155,147,194	Carbon Resistor, 3.3KΩ ¼W J	002-104-5-332
R-70	Carbon Resistor, 560Ω ¼W J	002-104-5-560
R-69	Carbon Resistor, 560Ω ¼W J	002-108-5-561
R-17,18	Carbon Resistor, 3.9KΩ ¼W J	002-104-5-392
R-65	Carbon Resistor, 4.7KΩ ¼W J	002-104-5-472
R-64,69,102,151,174,181 184	Carbon Resistor, 5.6KΩ ¼W J	002-104-5-562
R-168	Carbon Resistor, 6.8KΩ ¼W J	002-104-5-682
R-13	Carbon Resistor, 8.2KΩ ¼W J	002-104-5-822
R-11,12,66,118,130,135 152,153,159,175,177, 202,203,134,193	Carbon Resistor, 10KΩ ¼W J	002-104-5-103
R-138	Carbon Resistor 12KΩ ¼W J	002-104-5-123
R-121,124,141,20,68,76	Carbon Resistor, 15KΩ ¼W J	002-104-5-153
R-154,179,193,205	Carbon Resistor, 22KΩ ¼W J	002-104-5-223
R-55	Carbon Resistor, 18KΩ ¼W J	002-104-5-183
R-189	Carbon Resistor, 33KΩ ¼W J	002-104-5-333
R-183,186	Carbon Resistor, 39KΩ ¼W J	002-104-5-393

CIRCUIT SYMBOL	DESCRIPTION	PART NO.
RESISTORS (Continued)		
R-2	Carbon Resistor, 47KΩ ¼W J	002-104-5-473
R-122,123,125,127,129, 133,52	Carbon Resistor, 56KΩ ¼W J	002-104-5-563
R-178	Carbon Resistor, 68KΩ ¼W J	002-104-5-683
R-169	Carbon Resistor, 82KΩ ¼W J	002-104-5-823
R-149,176,156,157,158, 190,75	Carbon Resistor, 100KΩ ¼W J	002-104-5-104
R-170	Carbon Resistor, 120KΩ ¼W J	002-104-5-124
R-137	Carbon Resistor, 180KΩ ¼W J	002-104-5-184
R-128,132,15,61	Carbon Resistor, 220KΩ ¼W J	002-104-5-224
R-67,163	Carbon Resistor, 270KΩ ¼W J	002-104-5-274
R-14,126	Carbon Resistor, 470KΩ ¼W J	002-104-5-474
R-201	Carbon Resistor, 150Ω ¼W J	002-104-5-151
R-148	Carbon Resistor, 1KΩ ¼W J	002-104-5-102
R-204	Metalized Resistor, 100Ω 1W J	013-025-9-001
CAPACITORS		
CV-51,52,53	Trimmer Capacitor CV-021 70P	028-047-9-001
C-306,307,308,311 312,313	Feed Through Capacitor, CZ-029,006 1000P	033-030-9-001
C-11,13	Tantalum Capacitor, 0.22μF 35V M	027-026-9-001
C-12	Tantalum Capacitor, 0.47μF 35V M	027-026-9-002
C-141	Tantalum Capacitor, 4.7μF 35V M	027-026-9-003
C-178	Tantalum Capacitor, 4.7μF 16V M	027-026-9-004
C-154,155	Tantalum Capacitor, 4.7μF 10V M	027-026-9-005
C-158	Solid Aluminum Capacitor, 0.22μF 16V M	022-158-9-001
C-61	Polystyrol Capacitor, 130pF 125V J	030-040-9-001
C-16	Polystyrol Capacitor, 470pF 125V J	030-040-9-002
C-179	Electrolytic Capacitor, 0.47μF 50V	022-157-9-001
C-8,124,128,174,172	Electrolytic Capacitor, 1μF 50V	022-157-9-002
C-169	Electrolytic Capacitor, 2.2μF 25V	022-158-9-002
C-5,9,19,20,109,116	Electrolytic Capacitor, 4.7μF 25V	022-157-9-003
C-129,130,195,205,206	Electrolytic Capacitor, 10μF 16V	022-157-9-004
C-192,202	Electrolytic Capacitor, 33μF 16V	022-157-9-006
C-168,301,303	Electrolytic Capacitor, 100μF 16V	022-157-9-009
C-212,213	Electrolytic Capacitor, 330μF 16V	022-158-9-003
C-194,204	Electrolytic Capacitor, 470μF 16V	022-157-9-011
C-304	Electrolytic Capacitor, 1000μF 16V	022-158-9-004

CIRCUIT SYMBOL	DESCRIPTION	PART NO.
CAPACITORS (Continued)		
C-189,199	Electrolytic Capacitor, 33 μ F 10V	022-158-9-005
C-221	Electrolytic Capacitor, 47 μ F 10V	()
C-25	Electrolytic Capacitor, 470 μ F 10V	022-160-9-001
C-166,171,217	Electrolytic Capacitor, 100 μ F 10V	022-157-9-008
C-52	Electrolytic Capacitor, 22 μ F 6.3V	022-158-9-006
C-188,189	Electrolytic Capacitor, 100 μ F 6.3V	022-158-9-007
C-165	Electrolytic Capacitor, 470 μ F 6.3V	022-158-9-008
C-58,190,191,200,201	Mylar Capacitor, 0.001 μ F 50V K	025-122-9-001
C-10,21,22,57,197,187,125	Mylar Capacitor, 0.0033 μ F 50V K	025-122-9-002
C-23,24	Mylar Capacitor, 0.0068 μ F 50V K	025-122-9-003
C-56,59,184,179,222	Mylar Capacitor, 0.01 μ F 50V K	025-121-9-002
C-17,18,70,112,157,167,180,186,196,126	Mylar Capacitor, 0.022 μ F 50V K	025-121-9-003
C-173	Mylar Capacitor, 0.033 μ F 50V K	025-121-9-004
C-183,185	Mylar Capacitor, 0.039 μ F 50V K	025-121-9-005
C-15,51,53,66,119	Mylar Capacitor, 0.047 μ F 50V K	025-121-9-006
C-72,181,71	Mylar Capacitor, 0.068 μ F 50V K	025-122-9-004
C-182,193,203,309,310	Mylar Capacitor, 0.1 μ F 50V K	025-121-9-001
C-214	Ceramic Capacitor, 1pF 50V K SL	020-181-9-001
C-111	Ceramic Capacitor, 2pF 50V K SL	020-181-9-002
C-153	Ceramic Capacitor, 5pF 50V K SL	020-181-9-003
C-134	Ceramic Capacitor, 10pF 50V K SL	020-181-9-004
C-101	Ceramic Capacitor, 27pF 50V K SL	020-181-9-005
C-145	Ceramic Capacitor, 33pF 50V K SL	020-180-9-012
C-55,149	Ceramic Capacitor, 47pF 50V K SL	020-180-9-013
C-143	Ceramic Capacitor, 68pF 50V K SL	020-180-9-015
C-6,7	Ceramic Capacitor, 100pF 50V K SL	020-180-9-016
C-67	Ceramic Capacitor, 120pF 50V K SL	020-180-9-006
C-140	Ceramic Capacitor, 200pF 50V K SL	020-180-9-017
C-142,151,148	Ceramic Capacitor, 250pF 50V K SL	020-181-9-007
C-150,209	Ceramic Capacitor, 330pF 50V K SL	020-181-9-008
C-207	Ceramic Capacitor, 1pF 50V C CH	020-180-9-001
C-65	Ceramic Capacitor, 3pF 50V C CH	020-180-9-003
C-152	Ceramic Capacitor, 10pF 50V J CH	020-181-9-009
C-68	Ceramic Capacitor, 0.022 μ F 25V Z YG	020-186-9-002
C-161,162	Ceramic Capacitor, 22pF 50V J CH	020-181-9-010
C-54,133	Ceramic Capacitor, 100pF 50V K CH	020-181-9-011
C-211	Ceramic Capacitor, 150pF 50V K CH	020-181-9-012
C-218	Ceramic Capacitor, 7pF 50V J RH	020-181-9-013
C-219	Ceramic Capacitor, 47pF 50V K RH	020-181-9-014
C-210	Ceramic Capacitor, 330pF 50V K RH	020-181-9-015
C-14	Ceramic Capacitor, 680pF 50V K YP	020-181-9-016
C-1,2,3,4,25,73	Ceramic Capacitor, 0.022 μ F 25V Z YG	020-181-9-017
C-220	Ceramic Capacitor, 0.0022 μ F 25V Z YG	()
C-60,62,64,69,74	Ceramic Capacitor, 0.047 μ F 25V Z YG	020-181-9-018
C-160	Ceramic Capacitor, 0.001 μ F 25V Z YG	020-180-9-020
C-102,103,104,105,106,107,114,115,117,118,	Ceramic Capacitor, 0.01 μ F 25V Z YG	020-180-9-023

CIRCUIT SYMBOL	DESCRIPTION	PART NO.
CAPACITORS (Continued)		
C-121,122,123,131,136,146,147,156,159,164,175,215,216,302,208,135,223	Ceramic Capacitor, 0.01 μ F 25V Z YG	020-180-9-023
C-137,163	Ceramic Capacitor, 0.022 μ F 25V Z YG	020-181-9-019
C-110,113,120,139,144,305	Ceramic Capacitor, 0.039 μ F 25V Z YG	020-181-9-020
C-108	Ceramic Capacitor, 0.047 μ F 25V Z YG	020-181-9-021
C-132	Ceramic Capacitor, 0.001 μ F 25V K YB	020-181-9-022
C-138,176,214	Ceramic Capacitor, 0.0033 μ F 25V K YB	020-181-9-023
ARRAYS		
RR-101	Composite Parts, HA-012	527-081-9-001
RR-102,103	Composite Parts, HA-009	527-079-9-001
CC-101,102	Composite Parts, HA-003	527-077-9-002
CRYSTALS		
X-2	Crystal, QX-077	133-014-9-001
X-1	Crystal, QX-078	133-014-9-002
X-3	Crystal, QX-079	133-014-9-003
CERAMIC FILTER		
CF-2,1	FL-051, 10.7MHz IF (FM)	140-019-9-001
CF-101	FL-047 10.7MHz IF (CB)	140-018-9-001
CF-102	FL-049, 455Hz IF (CB)	140-018-9-002
SWITCHES		
S-1	Rotary Switch, SR-172	083-225-9-001
S-2	Rotary Switch, SR-173	083-225-9-002
S-4,5,6	Rotary Switch, SW-092	083-225-9-003
MISCELLANEOUS		
M-1	Meter, MT-086	320-085-9-001
RL-1	Relay, RL-025	441-018-9-001
P/J-101,103	Jack (5045-03A), JK-033	773-081-9-001
P-104	Jack (3022-15A), JK-039	773-081-9-002
P/J-1	Jack (5046-09A), JK-081	773-081-9-003
P/J-102	Jack (5048-04A), JK-032	773-081-9-004
M-11	Insulation Board, for 25C1975 YD-033	345-050-9-002
TP-1,2,3,4,5,6,7,8	Check Terminal, TP-020	757-028-9-001

COBRA 45XLR

CIRCUIT SYMBOL	DESCRIPTION	PART NO.
MISCELLANEOUS(Continued)		
PL-2	Pilot Lamp, PL-005 (yellow)	400-045-9-001
M-13	Tuner, Y-054	523-196-9-001
CN-1 (M14)	Coaxial Cable, WZ-024	426-023-9-001
CN-2 (M14)	Coaxial Cable, WZ-026	426-023-9-002
CN-3 (M15)	Microphone Cord, WZ-025	426-023-9-003
CN-4 (M16)	DC Cord, WZ-027	426-023-9-004
M-17	DC Cord, WZ-028	426-023-9-005
A-3	Microphone, Dynamic MK-046	562-006-9-001
A-1	NS Condenser, CZ-031 Metal Can 0.47 μ F 160V	021-062-9-001
M-18	Front Chassis (Comp)	258-018-9-001
M-18	Front Chassis, t=1.0	258-019-9-001
M-19	Rear Chassis, t=1.0	258-020-9-001
M-20,21	Cover, t=0.6	253-058-9-001
M-22	Subchassis (Comp) t=0.6	258-021-9-001
M-22	Subchassis t=1.2	258-021-9-001
M-22	Holder for Meter, t=0.8	251-212-9-001
M-22	LED Bracket, t=1.0	251-213-9-001
M-24	Clip for Metal, t=1.0	261-073-9-001
M-25	Tuner Bracket, t=1.0	251-214-9-001
M-25	Pulley Bracket (Comp)	251-215-9-001
M-25	Pulley Bracket, t=1.0	251-216-9-001
M-26	Gear Bracket, t=1.0	251-217-9-001
A-5	Perforated Support Bracket, t=1.0	251-218-9-001
M-27	Holder for Cord, t=0.5	251-219-9-001
M-28	Clip for Cord, t=0.8	261-073-9-002
M-29	Back Panel, spcc t=0.8	262-018-9-001
M-30	SW Holder Panel (Comp)	261-073-9-003
M-30	SW Holder panel, t=1.0	261-073-9-004
M-31	Bracket for Through Capacity, t=1.0	251-220-9-001
M-32	Filter Box t=0.8	763-089-9-001
M-33	Slide VR Through Capacity	763-089-9-002
M-34	Bracket for through Capacity, t=0.5	251-221-9-001
M-35	Holder for Oldham's Coupling PBP 1/2H t=0.6	251-222-9-001
M-36	Lamp Holder, PBP 1/2H t=0.3	752-013-9-001
M-37	Pointer, BSP3H t=0.5	261-073-9-005
M-38	Holder for IC, SUS-403 t=0.6	261-073-9-006
M-39	Heat Sink, t=2.0	747-053-9-001
M-40	Heat Sink, t=2.0	747-053-9-002
M-41	Lamp Holder, PBP 1/2H t=0.3	752-013-9-002
A-6	Microphone Hanger, spcc t=1.0 ni-3	741-074-9-001
M-42	Front Panel	255-153-9-001
A-8	Knob, ABS Cr-1 VR	751-150-9-001
A-9	Trim Plate	260-121-9-001
M-45	LED Holder	752-013-9-003
A-7	Knob, ABS Cr-1 CH Tuning	751-150-9-002
M-43	Knob, ABS Cr-1 Dyna Mike	751-150-9-003
M-43	Knob, ABS Cr-1 SO	751-150-9-004
M-44	Knob, Balance	751-150-9-005

COBRA 45XLR

CIRCUIT SYMBOL	DESCRIPTION	PART NO.
MISCELLANEOUS (Continued)		
M-45	Knob, Cr-1 Tone	751-150-9-006
M-45	Knob, Dim	751-150-9-007
M-47	Knob, ANL	751-150-9-008
M-48	Knob, MONI	751-150-9-009
M-49	Gear	743-004-9-001
M-46	Pulliey	743-004-9-002
M-52	Oldham's Coupling Tunner, CH, Tuning	743-004-9-003
M-53	Oldham's Coupling Switch Fixing Metal	743-004-9-004
M-54	Oldham's Coupling	743-004-9-005
M-50	Gear	743-004-9-006
M-51	Gear	743-004-9-007
M-55	Dial Indicator	261-073-9-007
M-56	Holder for code	251-223-9-001
A-2	Display Board, t=1.0	763-089-9-003
A-4	Display Board, t=1.0	763-089-9-004
M-57	FCC Name Palte, t=1.0	600-034-9-001
M-57	FCC Name Plate, t=0.3	600-034-9-002
M-57	FCC Name Plate, t=0.3	600-034-9-003
M-57	Microphone Plate, t=0.3	600 034-9-004
M-57	Seal	600-034-9-005
M-57	Seal	600-034-9-006
M-57	Production No.Seal	-NA-
M-57	Serial Label	-NA-
M-57	Tag	484-048-9-001
M-57	Tag	484-048-9-002
M-57	Tag	484-048-9-003
M-57	Tag	484-048-9-004
M-57	Shaft, BSBM Front Chassis	261-073-9-008
M-57	Shaft, BSBM Pulley Bracket	261-073-9-009
M-57	Shaft, BSBM Switch Fixing Metal	261-073-9-010
M-57	Shaft, BSBM Switch Fixing Metal	261-073-9-011
M-57	Shaft, BSBM Switch Fixing Metal	261-073-9-012
M-82	Stud, BSBM	261-073-9-013
M-63	Philip Screw, Ni-3 SWRM-3	634-087-9-001
M-63	LED Cover	753-008-9-001
M-80	Slit Cover	253-059-0-001
M-62	Fiber	763-089-9-005
M-64	Dial Spring	767-050-9-001
M-81	Slit Cover	253-060-9-001
M-83	LED Cap	753-008-9-002
M-58	Cushion	763-089-9-006
M-65	Dial String	763-089-9-007
M-68	Bind Screw, M2 x 4	634-069-9-002
M-69	Bind Screw, M2.6 x 5	634-067-9-003
M-70	Screw, M2.6 x 4	634-087-9-002
M-72	Bind Screw, M3 x 5	634-067-9-001
M-73	Bind Screw, M3 x 8	634-067-9-002
M-71	Bind Screw, M3 x 4	634-087-9-003



Cobra Communications Product Group

DYNASCAN CORPORATION

6460 W. Cortland Street

Chicago, Illinois 60635