

This Information Is Provided By
CBTricks.com

Cobra 41 Plus Service Manual

Liability of damages to any equipment is the sole responsibility of the user! Downloading, viewing, or using any information provided on these pages automatically accepts the user to the terms of this agreement!

Modifications are provided for information purposes only!

Supporters of CBTricks.com paid for the hosting so you would have this file.

CBTricks.com is a non-commercial personal website was created to help promote the exchange of service, modification, technically oriented information, and historical information aimed at the Citizens Band, GMRS (CB "A" Band), MURS, Amateur Radios and RF Amps.

CBTricks.com is not sponsored by or connected to any Retailer, Radio, Antenna Manufacturer or Amp Manufacturer, or affiliated with any site links shown in the links database. The use of product or company names on my web site is not endorsement of that product or company.

The site is supported with donations from users, friends and selling of the Site Supporters DVD's to cover some of the costs of having this website on the Internet instead of relying on banner ads, pop-up ads, commercial links, etc. Thus I do not accept advertising banners or pop-up/pop-under advertising or other marketing/sales links or gimmicks on my website.

ALL the money from donations is used for CBTricks.com I didn't do all the work to make money (I have a day job). This work was not done for someone else to make money also, for example the ebay CD sellers.

All Trademarks, Logos, and Brand Names are the property of their respective owners.

This information is not provided by, or affiliated in any way with any radio or antenna Manufacturers.

Thank you for any support you can give.

For information on how to Support CBTricks.com

<http://www.cbtricks.com/support/>

SERVICE MANUAL

SERVICE MANUAL

 **Cobra®**

41 PLUS CB RADIO

America's Most Recognized Name In CB Communication



MODEL 41 PLUS

 **Cobra®**
CONSUMER ELECTRONICS GROUP

DYNASCAN CORPORATION

6500 West Cortland Street • Chicago, Illinois 60635
(312) 889-8870 TELEX: 244-332

TABLE OF CONTENTS

Model 41 PLUS

Operating Theory of P.L.L. Frequency Synthesizer	50
Transmitter Circuit	53
Receiver Circuit	55
Weather Band Circuit	57
P.C.B. Top View	59
P.C.B. Bottom View	60
Wiring Diagram	61
P.C.B. Wiring Diagram	62
Semiconductor Lead Identification and IC Internal Diagram	63
Semiconductor Complement and Function	65
Voltage Chart	66
Exploded View	67
Exploded View Part List	68
Part List	69
Block Diagram	70
Schematic Diagram	71

1. OPERATING THEORY OF P.L.L. FREQUENCY SYNTHESIZER

1-1 Fundamental Theory of PLL Circuitry

The purpose of P.L.L. (Phase Locked Loop) circuit is to generate multiple number programmable frequencies from a signal reference frequency with quartz crystal accuracy. A basic PLL circuitry consists of reference oscillator, VCO phase comparator and DC filter (low pass filter). With the above circuit the VCO (Voltage Controlled Oscillator) Frequency is effectively locked to the reference oscillator and its accuracy is as good as the reference oscillator.

Since the CB radio's adjacent channel spacing is 10kHz (or multiple of 2.5kHz), our purpose should be to produce multiple of programmable frequencies that are spaced apart by 10kHz.

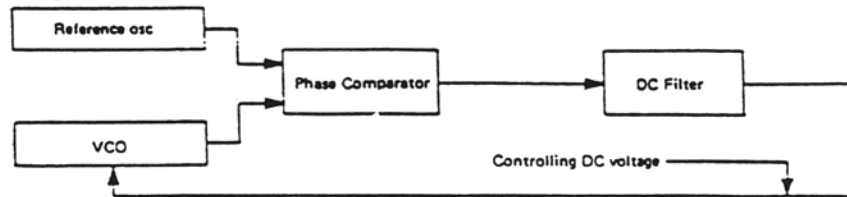

(Figure 1-1)



(Figure 1-2)

Therefore the basic PLL circuitry is expanded as follows:

Note that the reference frequency of 2.5kHz is obtained by dividing the 10.24mhz by 4096 times. (2.5kHz reference is used instead of 10kHz for division convenience).

See Table 1 for transmit/receive mode VCO frequencies. The most important part of VCO circuitry is a voltage controlled variable capacitor called vari-cap or varactor diode whose capacitance depends on DC voltage applied to its cathode. The varactor diode is responsible for setting VCO frequency, and once set it regulates the VCO frequency against the reference. The VCO frequencies are chosen in 13 to 16mHz range as shown on Table 1. To obtain transmit signal the VCO is doubled. As an example for channel 1:
 $13.4825 \times 2 = 26.965 \text{mHz}$.
 For receiver mode the VCO is used as a first local oscillator. For channel 1:
 $26.965 - 16.27 = 10.695 \text{mHz}$.

The above first IF of 10.695MHz is mixed again with 10.24MHz crystal oscillator frequency which serves as the second local oscillator.
 $10.695 - 10.24 = 0.455\text{MHz}$.

As can be seen above the VCO frequency shifts from 13.4825 to 16.27MHz when changed from transmit to receive for the same channel 1.

The shift is accomplished by "read only memory" incorporated inside the PLL IC1 between the selector switch and the VCO divider (programmable).

When transmit logic signal is applied to the IC1 through pin 30, the programmable divider will divide incoming VCO frequency by 5393 to product 2.5kHz sampling signal.
 $13.4825 \times 5393 = 2.5\text{kHz}$.

For the receiver mode the programmable divider will automatically change to divide the VCO frequency by 3254.
 $16.27 \times 3254 = 5\text{kHz}$.

1-2 PLL Circuit Alignment

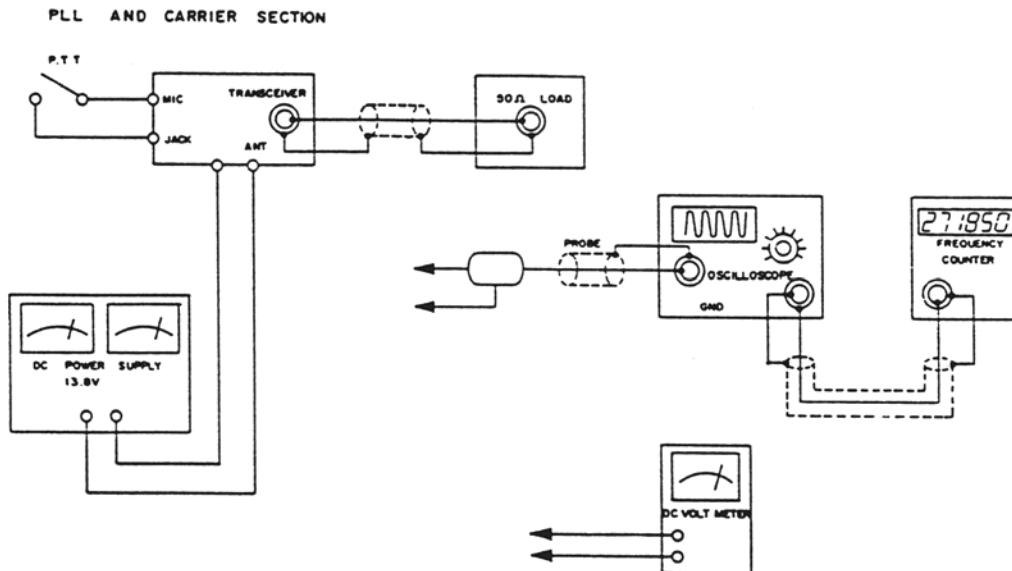

(Figure 1-3)

1-3 10.24MHz

Connect a frequency counter to the pin 20 and check to see 10.24000MHz-100Hz. When a defective crystal is replaced, and if the frequency is higher than by 100Hz, the CTI should be increased. If the frequency is lower the CTI should be reduced in capacitance.

1-4 VCO Alignment

1. Set the radio to channel 40 and in receive mode.
2. Connect a circuit tester between C82 and ground.
3. Adjust L14 to obtain 3V DC.
4. Set the radio to channel 1 and in receive mode.
5. Check to see the TP/DC voltage dropping to a level between 1.3 to 1.5V DC.

As long as the DC level stays between 3V DC for receiver at channel 40 and 1.3 to 1.5V DC for receiver at channel 1 the VCO is set properly.

1-5 Frequency chart

(Table 1)

CH NO.	CHANNEL FREQ (MHz)	CRYSTAL OSC	VCO	
			TX	RX
1	26.965	10.24	13.4825	16.27
2	26.975	10.24	13.4875	16.28
3	26.985	10.24	13.4925	16.29
4	27.005	10.24	13.5025	16.31
5	27.015	10.24	13.5075	16.32
6	27.025	10.24	13.5125	16.33
7	27.035	10.24	13.5175	16.34
8	27.055	10.24	13.5275	16.36
9	27.065	10.24	13.5325	16.37
10	27.075	10.24	13.5375	16.38
11	27.085	10.24	13.5425	16.39
12	27.105	10.24	13.5525	16.41
13	27.115	10.24	13.5575	16.42
14	27.125	10.24	13.5625	16.43
15	27.135	10.24	13.5675	16.44
16	27.155	10.24	13.5775	16.46
17	27.165	10.24	13.5825	16.47
18	27.175	10.24	13.5875	16.48
19	27.185	10.24	13.5925	16.49
20	27.205	10.24	13.6025	16.51
21	27.215	10.24	13.6075	16.52
22	27.225	10.24	13.6125	16.53
23	27.255	10.24	13.6275	16.56
24	27.235	10.24	13.6175	16.54
25	27.245	10.24	13.6225	15.55
26	27.265	10.24	13.6325	16.57
27	27.275	10.24	13.6375	16.58
28	27.285	10.24	13.6425	16.59
29	27.295	10.24	13.6475	16.60
30	27.305	10.24	13.6525	16.61
31	27.315	10.24	13.6575	16.62
32	27.325	10.24	13.6625	16.63
33	27.335	10.24	13.6675	16.64
34	27.345	10.24	13.6725	16.65
35	27.355	10.24	13.6775	16.66
36	27.365	10.24	13.6825	16.67
37	27.375	10.24	13.6875	16.68
38	27.385	10.24	13.6925	16.69
39	27.395	10.24	13.6975	16.70
40	27.405	10.24	13.7025	16.71

2. TRANSMITTER CIRCUIT

The VCO frequency selected by the channel selector switch is doubled to generate desired transmit frequency. The doubling is done by the Q29.

The resulting transmit frequency is filtered by L15 and L16.

Q30 is an amplifier/switch circuit. When VCO frequency is out of "Lock" condition pin 18 of IC1 pulls down bias voltage of Q30 to ground disabling Q30 from passing possible illegal frequencies.

Q31 is a RF power driver circuit, and Q32 is the final RF power amplifier.

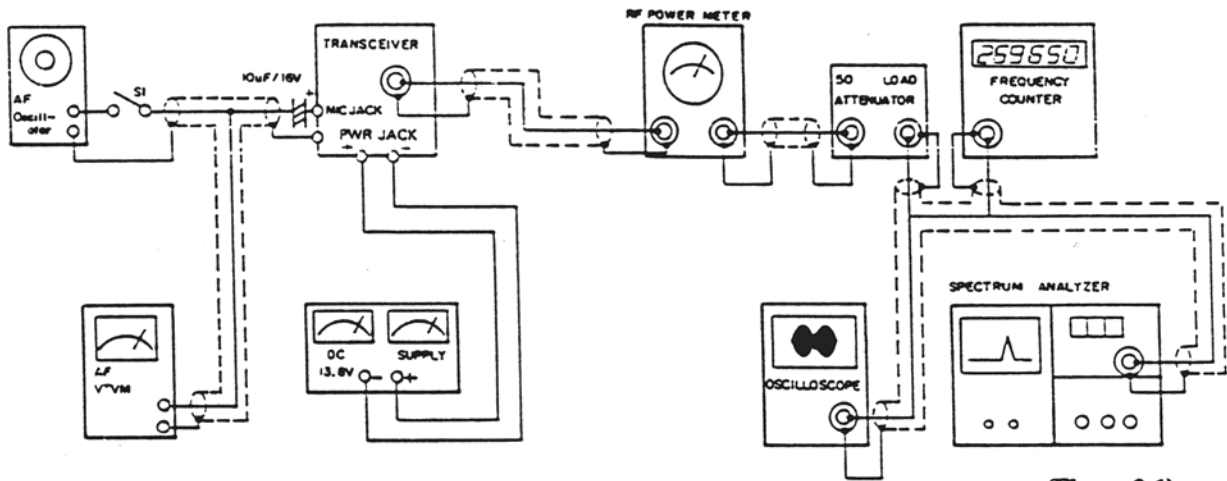

(Figure 2-1)

A modulating audio signal is applied to the collectors of Q31 and Q32 through a audio power transformer T1. The audio signal (mic input) is amplified by a single power IC2.

The modulation limiting is accomplished by an automatic level control circuit switch which is as follows:

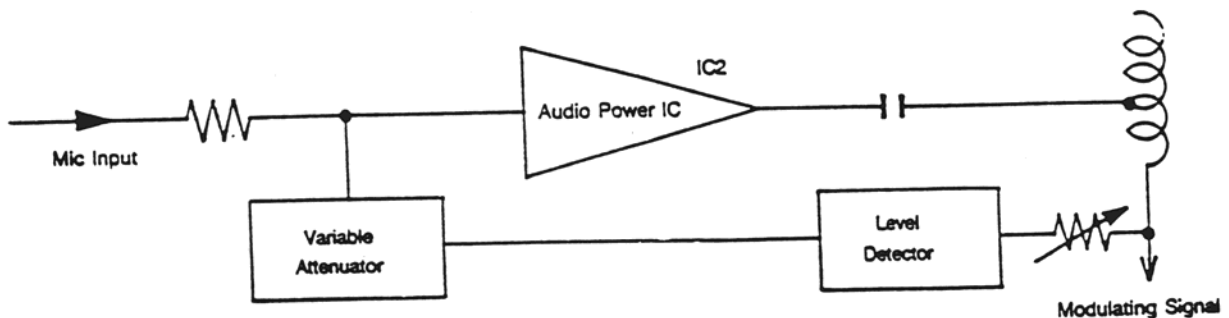

(Figure 2-2)

L19 and C163 are series resonator, and L20, 21, C165 and C166 make up pie-low pass filter. L19 is factory selected and limits the RF output power level to within the FCC limit of 4 watts.

2-1 RF Driver Stage Alignment

1. Select channel "19".
2. Connect an oscilloscope to the base of Q30 and ground.
3. Adjust L15, and L16 for maximum amplitude of scope display (27.185MHz signal).
4. Connect the scope to Q31 collector.
5. Adjust L17 for maximum amplitude of scope display.

2-2 RF Power Amplifier Alignment

1. Set power supply voltage to 13.8V.
2. Connect a watt meter to the antenna connector.
3. Adjust L19 for maximum power indication. Also again touch up L15, L16 and L17 to peak power.
4. When all coils are peaked, the power meter should indicate above 4.0 watts.
5. Turn L19 until the power reading of 4.0 watts is obtained.

2-3 Transmit Frequency Check

1. Set the radio into transmit mode with no modulation.
2. Connect the frequency counter to the antenna load or to the tab provided at the wattmeter. The frequency should be within $\pm 800\text{Hz}$ from each channel center frequency as tabulated in the frequency table attached.

2-4 Modulation Sensitivity Alignment

1. Set the unit into transmit mode and apply 6mV, 1kHz signal to the Mic input circuit.
2. RV4 should be adjusted to obtain 85% modulation at this condition.
3. Next, decrease signal input to 10mV and observe that the modulation ratio is keeping the value higher than 30%.

2-5 Transmit Power Indicator Alignment

1. Set the unit into transmit mode with no modulation.
2. Adjust RV2 right after the NO.5 LED just lights on.

3. RECEIVER CIRCUIT

In the receiver mode of operation, Q24 transistor is turned off.

Also bias voltage is applied to Q24 and a proper bias and AGC voltage is established to Q12, Q13, Q14 and Q15.

Q12 is a 27MHz RF input amplifier and any excessive input signal is limited by diodes D12, 14.

The amplified 27MHz is mixed with VCO frequency selected by channel switch.

For channel 1 VCO is set at 16.27MHz. The resulting first IF is $26.965 - 16.27 = 10.695\text{MHz}$.

Q13 is the first converter, and the 10.695MHz is sharply filtered by L11 and a ceramic filter CF-1.

The first IF is again mixed with a second local oscillator or 10.24MHz. $10.695 - 10.24 = 0.445\text{MHz}$. Q14 is the second converter and the 455kHz second IF is filtered by a razor sharp ceramic filter of CF-2 coupled with L12 & Q15 (455kHz amplifier).

D18 is a detector diode which produces audio signal as well as a negative DC voltage for AGC action. The negative voltage also provides forward biasing to the emitter of ANL clipping Tr of Q34.

The biasing voltage has a time constance determined by R73 and C70.

3-1 Receiver Section

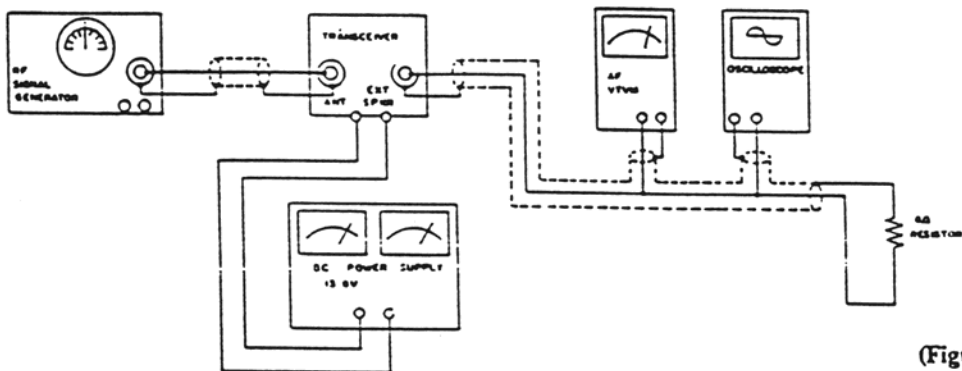

(Figure 3-1)

3-2 Receiver Sensitivity Alignment

1. Set the signal generator at 27.185MHz, 1kHz and 30% modulation. Also set the radio to Channel 19.
2. Adjust L8, L9, L10, L11, L12 and L13 for maximum audio output across the 8 ohm dummy load resistor. This alignment should be performed by gradually decreasing the signal generator output signal to a minimum level required for tuning to avoid inaccurate alignment due to AGC action.

3-3 Squelch Circuit Alignment

1. Set the signal to provide RF input signal of 1MV (60dB) (1kHz, 30% modulation).
2. Rotate the squelch control in full clockwise direction.
3. Temporarily adjust RV3 for maximum audio output, and note the audio output level. Then adjust RV3 so that the audio output level decreases by 6dB.

3-4 Receiver Signal Indicator Alignment

1. Set the signal generator to provide RF input signal of 100uV (40dB) (1kHz, 30% modulation).
2. Adjust RV1, right after the NO.4 LED just on.
3. Reduce antenna input signal level to 0-10 and check to see if the first LED light is on.

4. WEATHER BAND CIRCUIT

List of Test Equipment

1. Narrow-band crystal controlled FM signal generator with calibrated output from 100 microvolts to 1 microvolt and RF leakage less than 0.1 microvolt. Frequencies of 162.55, 162.475 and 162.40MHz \pm 1kHz.
2. Vacuum Tube Voltmeter or high input impedance solid state voltmeter.
3. Oscilloscope.

General Preparation

1. Check source voltage for DC 13.8V.
2. Set CHANNEL switch to channel being aligned.
3. Use crystal controlled narrow-band FM generator for 162.55, 162.475 and 162.40MHz.
4. Standard modulation is 1kHz. \pm 5kHz deviation for alignment and sensitivity tests.
5. Disconnect the Ant. wire from the Ant.

4-1 Weather Band Alignment Procedure

Note: During alignment, keep the RF input reduced to a level so that wave form is visible.

Step	Generator Connection	Generator Frequency	Channel	Meter Connection	Adjustment	Remarks
1		162.475MHz	W2	Across voice coil of speaker	L 4, 6	Adjust for max noise
2					L 2, 4, 6 and L 5 (Stretch Squeeze)	Adjust for maximum output
3	Repeat Step 2 until no further improvement is possible					
4	Same as Step 1	162.40MHz	W3	Same as Step 1	L 7	Adjust for maximum output
5	Same as Step 1	162.55MHz	W1 Step 1	Same as	CT-2	Adjust for maximum output

4-2 Weather band general specifications.

Test Condition

1. Speaker Impedance : 8 ohms (use resistive Load)
2. Reference Output Level : 500mW (total power)
3. Ambient Temperature : 25°C
4. Power Supply : 13.8V D.C

Weather

1. Test Frequency : 162.55MHz, 162.475MHz, 162.400MHz
2. Modulation : 1KHz, ± 5 KHz deviation

	UNIT	NOMINAL	LIMIT
Sensitivity (6dB S/N)			
162.55MHz	uV	0.7	1.0
162.40MHz	uV	0.7	1.0
162.475MHz	uV	0.7	1.0
20dB Quieting Sensitivity			
162.55MHz	uV	0.7	1.0
162.40MHz	uV	0.7	1.0
162.475MHz	uV	0.7	1.0
- 30dB Limiting Sensitivity			
162.55MHz	uV	0.7	9.5
96.6 or 97.7MHz Rejection	dB	70	60
De-emphasis, 1000Hz to 2000Hz	dB	-6	-3 to -9
Distortion, 1mV input	%	3	10
10% THD power output, 1mV input	W	4.2	3.0
Maximum power output, 1mV input	W	4.5	3.5
Current drain at No. signal volume Min.	mA	180	200

P.C.B. Top View

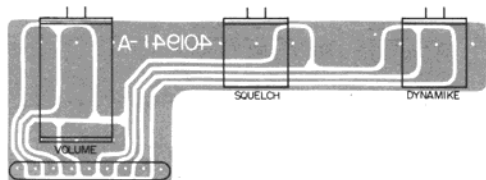
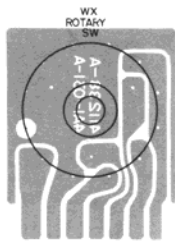
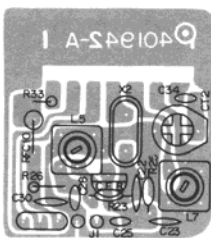
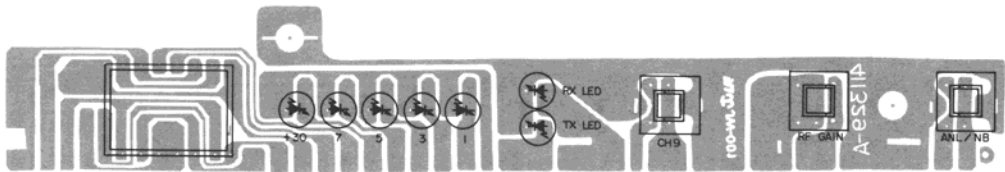
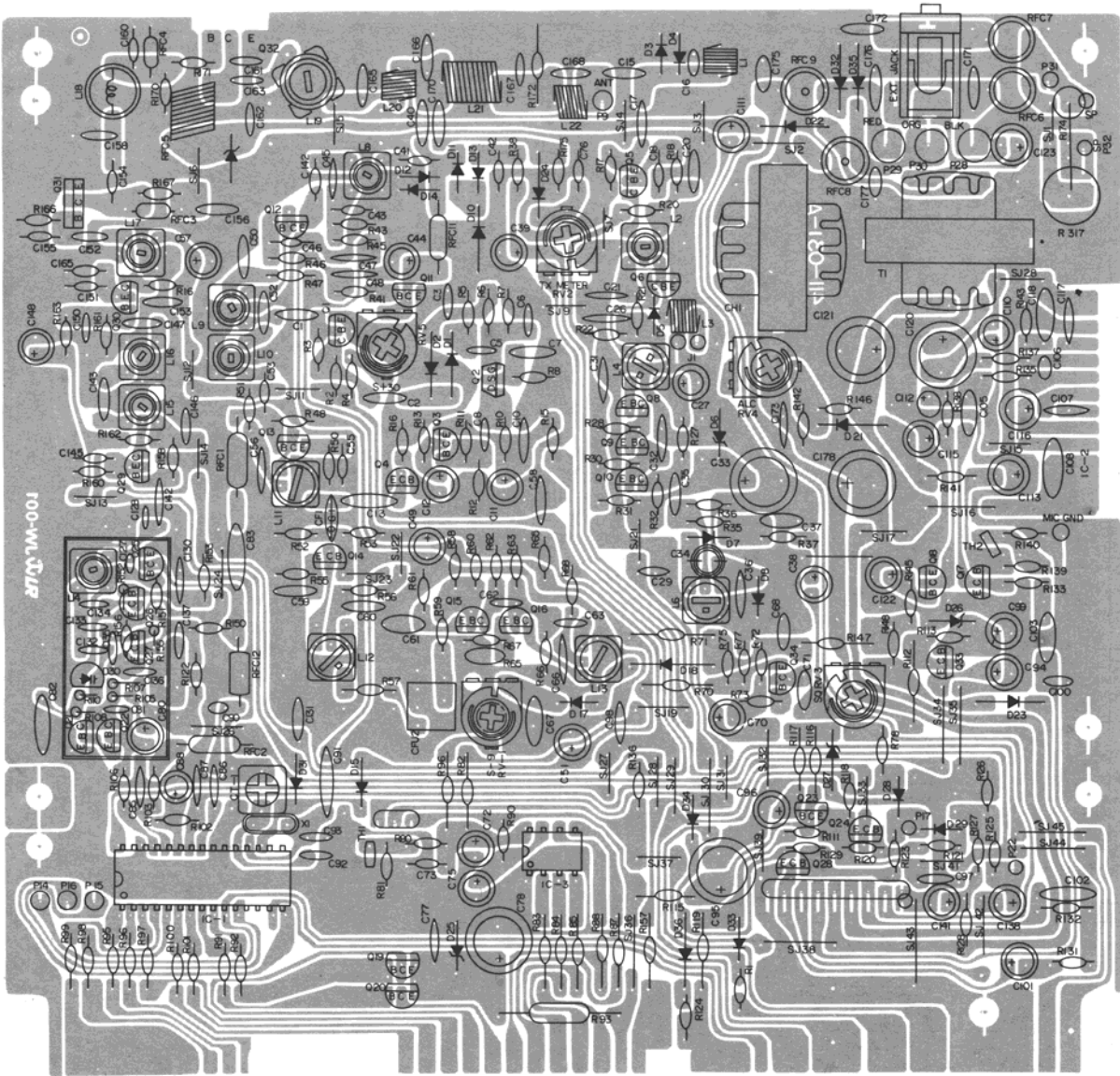

P.C.B. Bottom View

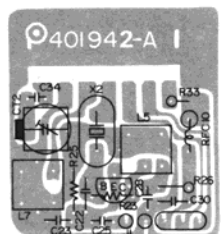
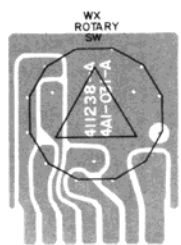
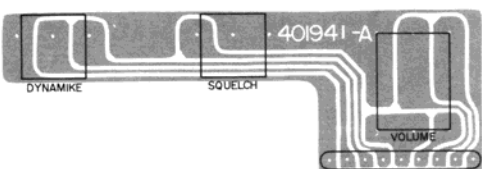
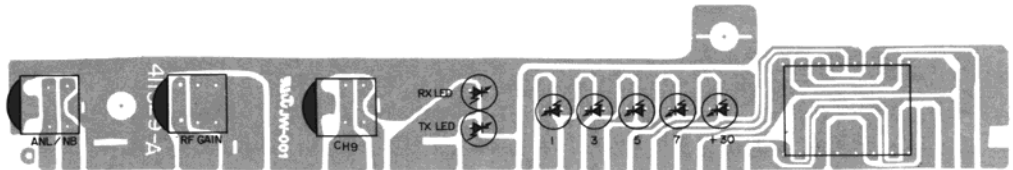
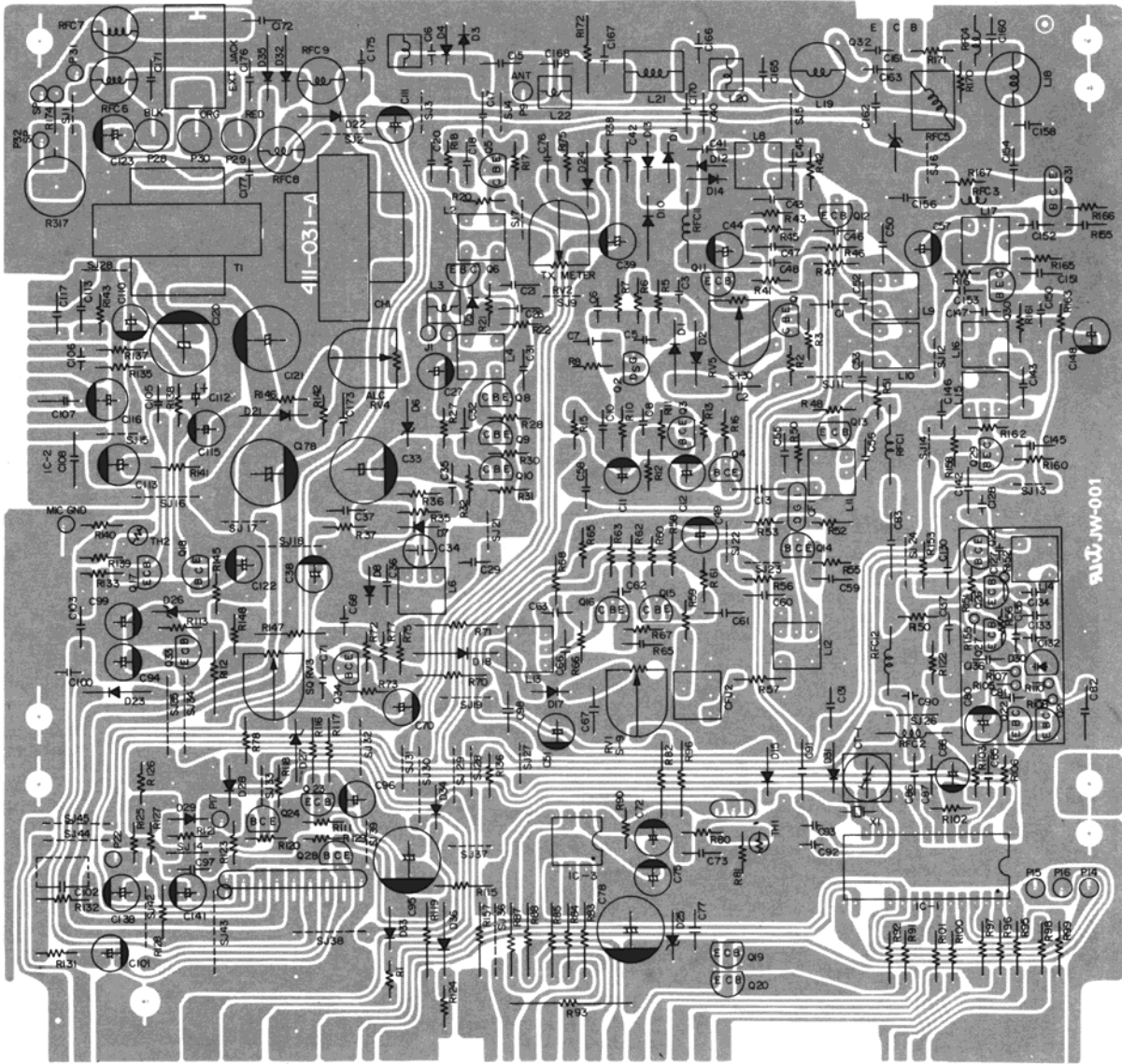

Wiring Diagram

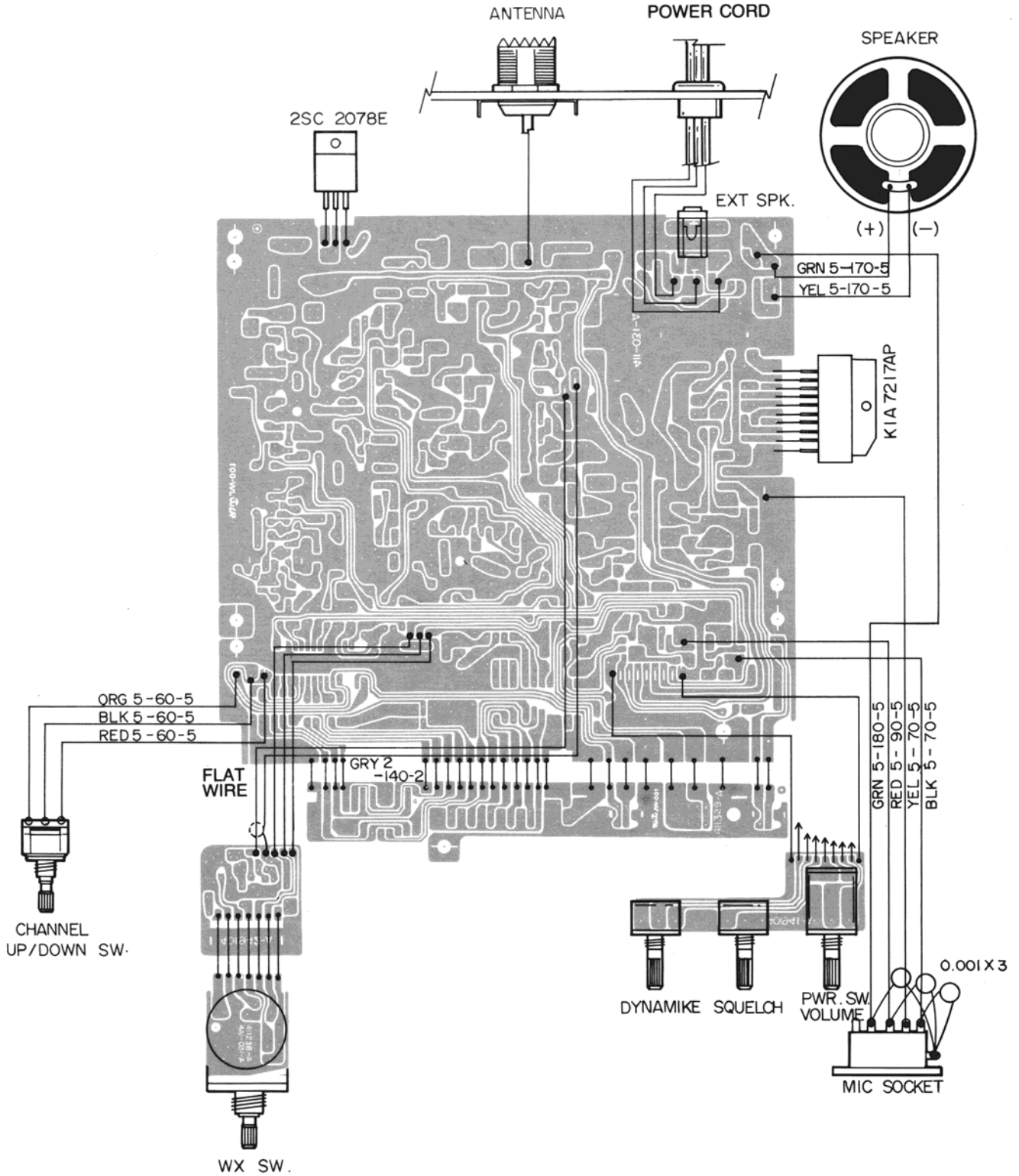

P.C.B. Wiring Diagram

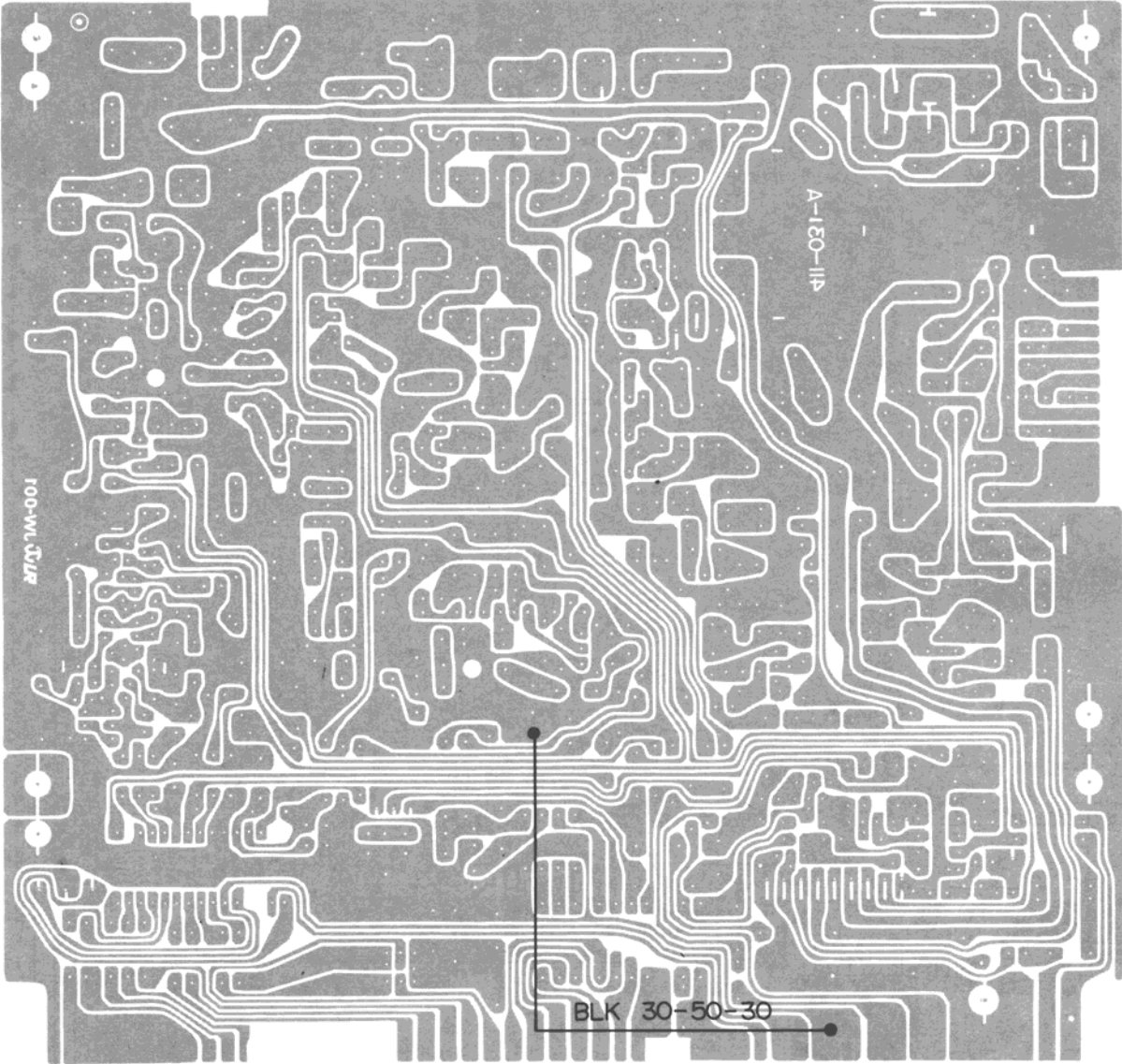

Semiconductor Lead Identification and IC Internal Diagram

Integrated Circuits

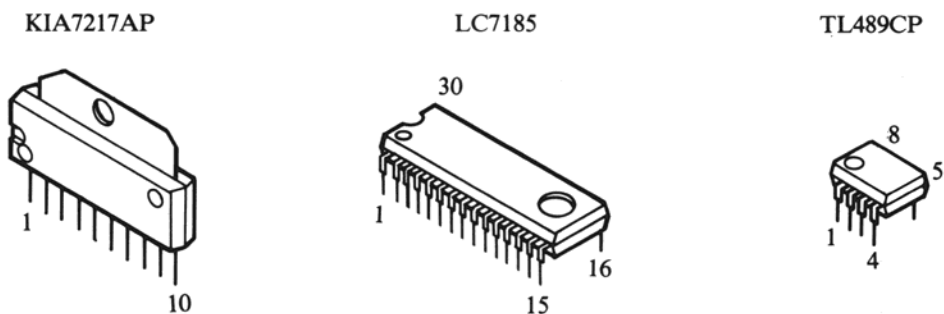

Transistors

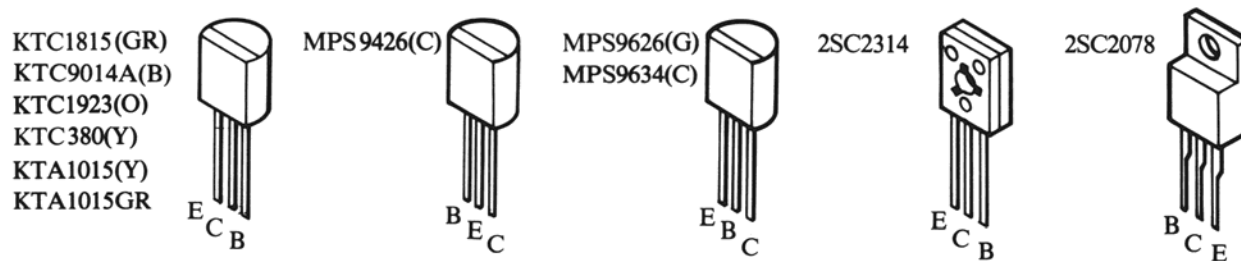

Diodes

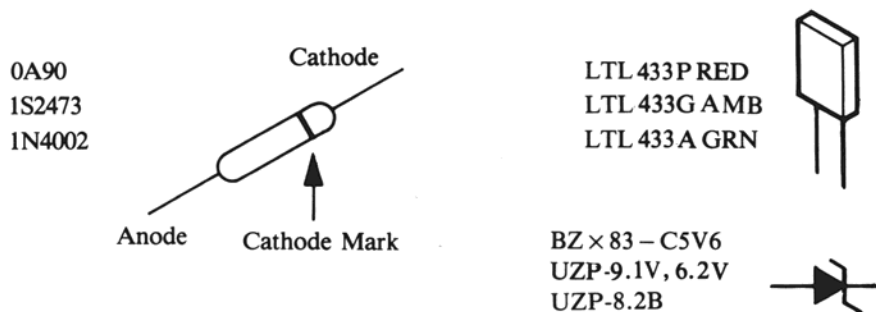

LTD-482GC-RE

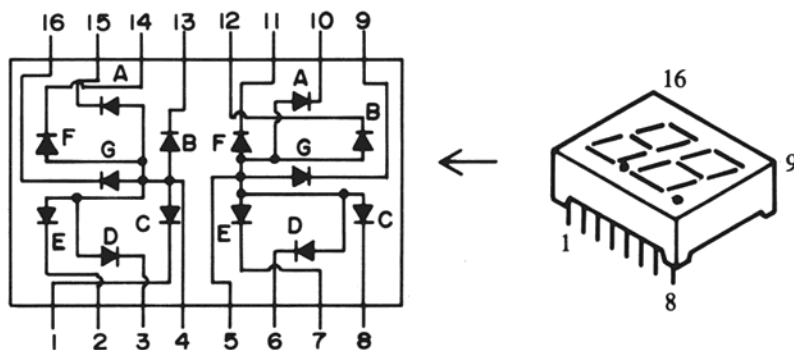

IC Internal Diagram

KIA 7217AP Schematic Diagram

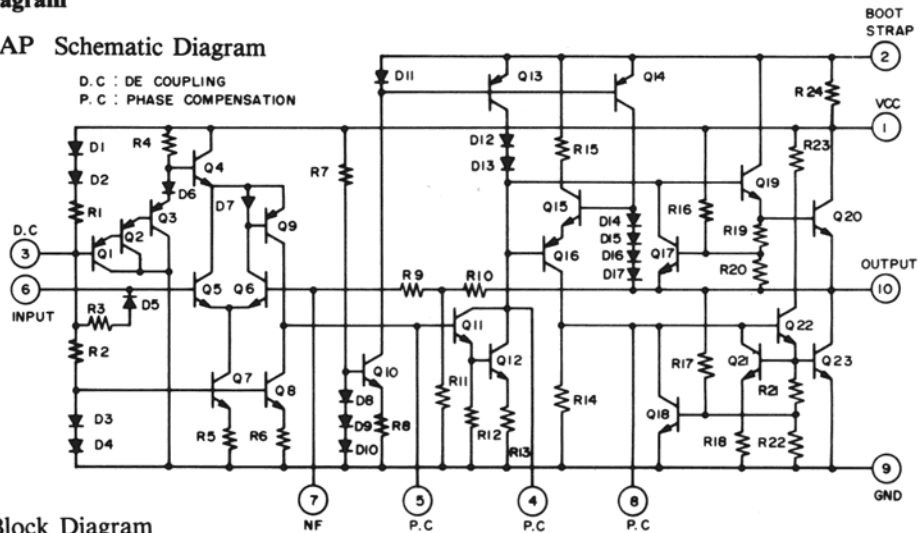

LC7185 Block Diagram

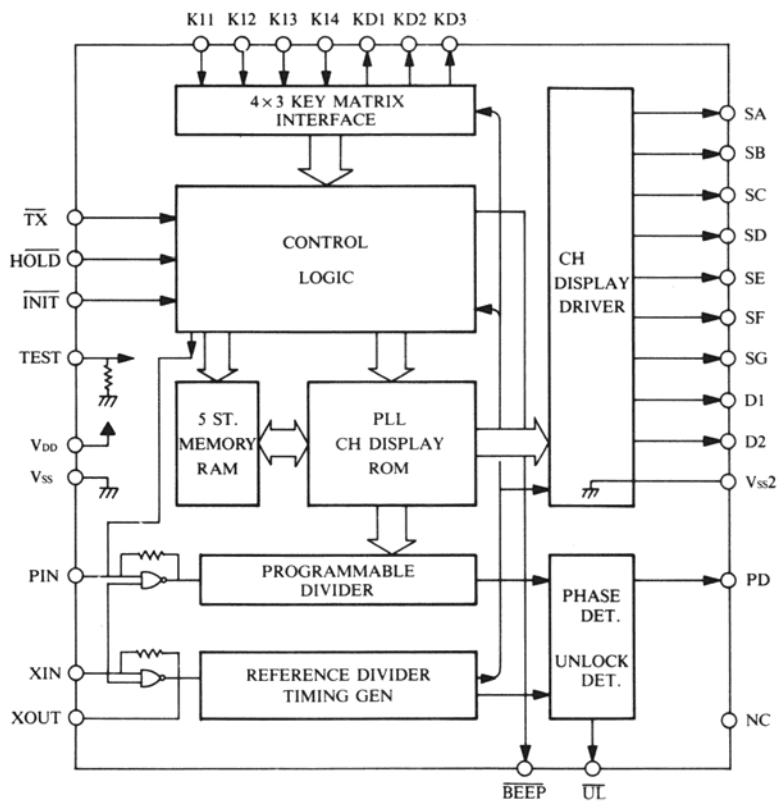

TL489CP Block Diagram

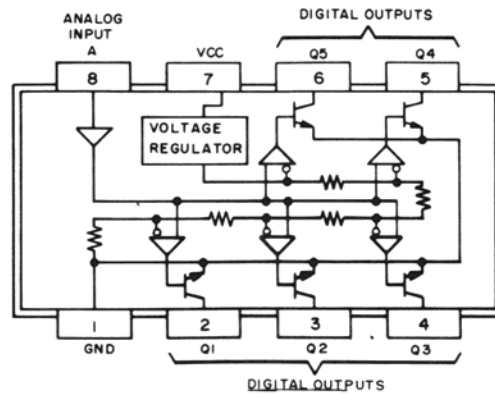

SEMICONDUCTOR COMPLEMENT AND FUNCTION.

REF. NO	TYPE	FUNCTION IN RX	FUNCTION IN TX	MANUFACTURE
IC1	LC7185	PLL	PLL	SANYO
IC2	KIA7217AP	A/F PWR AMP	A/F PWR AMP	K.E.C
IC3	TL489CP	LED LAMP DRIVER	LED LAMP DRIVER	T.I
Q1	KTC9018A (H)	NOISE BLANKER	NONE	KEC
Q2	KTCK161(Y)	NOISE BLANKER	NONE	KEC
Q3	KTA1015(GR)	NOISE BLANKER	NONE	KEC
Q4	KTC1959(O)	NOISE BLANKER	NONE	KEC
Q5, 6	MPS9626(G)	WX	NONE	MOTOROLA
Q7	MPS9426(C)	WX	NONE	MOTOROLA
Q8, 9, 10	KTC9104A(B)	WX	NONE	KEC
Q11	KTC1923(O)	RX RF ATTENUATOR	NONE	KEC
Q12	KTC1923(O)	RX AMP	NONE	KEC
Q13	KTC1923(Y)	FIRST MIXER	NONE	KEC
Q14	KTEC1923(O)	SECOND MIXER	NONE	KEC
Q15, 16	MSP9623(I)	IF AMP	NONE	MOTOROLA
Q17	KTA1015(GR)	NONE	ALC	KEC
Q18	KTEC1815(GR)	SQ CONTROL	NONE	KEC
Q19, 20	KTA1015(GR)	LED DISPLAY DRIVER	LED DISPLAY DRIVER	KEC
Q21, 22	MPS9634(C)	VCO CHARGE PUMP	VCO CHARGE PUMP	MOTOROLA
Q23	KTC1815(GR)	REGULATOR	REGULATOR	KEC
Q24	KTA1015(GR)	NONE	TX B ⁺ SW	KEC
Q25	KTC1923(O)	VCO BUFFER	VCO BUFFER	KEC
Q26	KTC1815(GR)	NONE	TX VOC SW	KEC
Q27	KTC1923(O)	VCO	VCO	KEC
Q28	KTEC1815(GR)	A/F FIX SW	NONE	KEC
Q29	MPS9426(C)	NONE	TX DOUBLER	MOTOROLA
Q30	MPS9426(C)	NONE	TX PRE AMP	MOTOROLA
Q31	2SSC2314	NONE	TX DRIVER AMP	SANYO
Q32	2SC2078	NONE	TX FINAL AMP	SANYO
Q33	KTC1815 (GR)	PLL REGULATOR	PLL REGULATOR	KEC
Q34	KTA1015(GR)	ANL	NONE	KEC

SANYO : TOKYO SANYO ELECTRIC CO., LTD.

KEC : KOREA ELECTRONICS CO., LTD.

TI : TEXAS INSTRUMENTS INCORPORATION

MOTOROLA : MOTOROLA SEMICONDUCTOR PRODUCTS INC.

Voltage Chart

CONDITIONS MEASURED ON CH 19
NO SIGNAL
NO MODULATION

1. Transistor

TR NO		E	C	B	TR NO		E	C	B	TR NO		E	C	B
Q1	RX	0	5.6	0.7	Q14	RX	0	5.0	0.6	Q25	RX	0	3.0	0.7
	TX	0	5.6	0.7		TX	0	0.8	0		TX	0	3.0	0.1
		G	D	S										
Q2	RX	0	6.1	1.7	Q15	RX	0.7	4.5	1.4	Q26	RX	0	0	0
	TX	0	6.2	1.6		TX	0	0.8	0.4		TX	0	0	0.7
		E	C	B										
Q3	RX	6.5	1.7	5.8	Q16	RX	0.4	13.8	1.1	Q27	RX	4.8	8.0	4.2
	TX	6.5	1.8	5.8		TX	0	13.8	0.2		TX	4.8	8.0	4.2
Q4	RX	0	0	0	Q17	RX	0	0	0.1	Q28	RX	0	0	0.6
	TX	0	0	0		TX	0	0	0.1		TX	0	0	0
Q5	RX	0	0	0	Q18	RX	0	3.5	0.2	Q29	RX	0	0	0
	TX	0	0	0		TX	0	3.4	0.1		TX	1.4	8.2	2.1
Q6	RX	0.3	4.1	0.9	Q19	RX	7.5	7.3	7.0	Q30	RX	0	13.8	0
Q7	RX	0	1.8	0.7		TX	7.3	7.1	7.6		TX	1.0	13.7	1.9
Q8	RX	1.3	4.0	2.0	Q20	RX	7.4	7.1	7.0	Q31	RX	0	13.8	0
	TX	0	0.6	0.6		TX	7.3	7.0	7.6		TX	0	13.8	0
Q9	RX	0	0.6	0.6	Q21	RX	0.6	2.4	1.0	Q32	RX	0	13.7	0
	TX	0	1.3	0.6		TX	0.6	2.5	1.1		TX	0	13.7	0
Q10	RX	0	0.2	0.8	Q22	RX	0	2.4	0.6	Q33	RX	5.5	13.8	6.2
	TX	0	0	0.4		TX	0	2.5	0.6		TX	5.5	13.8	6.2
Q11	RX	0.5	0.5	1.3	Q23	RX	8.4	13.8	9.4	Q34	RX	0.1	0	0.4
	TX	0	0.8	0.4		TX	8.4	13.4	9.4		TX	0.1	0	0.1
Q12	RX	0.4	11.5	1.2	Q24	RX	8.4	0	8.4					
	TX	0	13.0	0.5		TX	8.4	8.4	7.4					

2. ICs

N.C=No Connection

IC No	Pin No	RX	TX	IC No	Pin No	RX	TX	IC No	Pin No	RX	TX	
IC 1	1	5.6	5.6	IC 2	17	N.C	N.C	IC 2	3	3.92	3.82	
	2	0.7	0.7		18	1.0	4.9		4	8.05	7.85	
	3	0.7	0.7		19	2.6	3.6		5	1.43	1.39	
	4	5.6	5.6		20	2.2	2.2		6	3.25	3.13	
	5	5.8	5.8		21	0	0		7	3.41	3.31	
	6	5.6	5.6		22	0	0		8	1.18	1.22	
	7	5.6	5.6		23	2.5	2.5		9	0	0	
	8	7.8	7.8		24	5.5	5.5		10	6.82	6.63	
	9	7.9	7.9		25	4.5	4.5		IC 4	1	0	0
	10	0	0		26	8.5	8.5			2	10.59	0.07
	11	0	0		27	0.6	1.0	3		10.59	0.07	
	12	N.C	N.C		28	0	0	4		10.64	0.07	
	13	N.C	N.C		29	N.C	N.C	5		10.72	0.07	
	14	5.4	5.4		30	5.1	1.0	6		11.08	0.07	
	15	5.4	5.4		1	13.70	13.32	7		12.68	11.40	
	16	N.C	N.C		2	12.56	12.19	8		0	1.7	

Exploded View

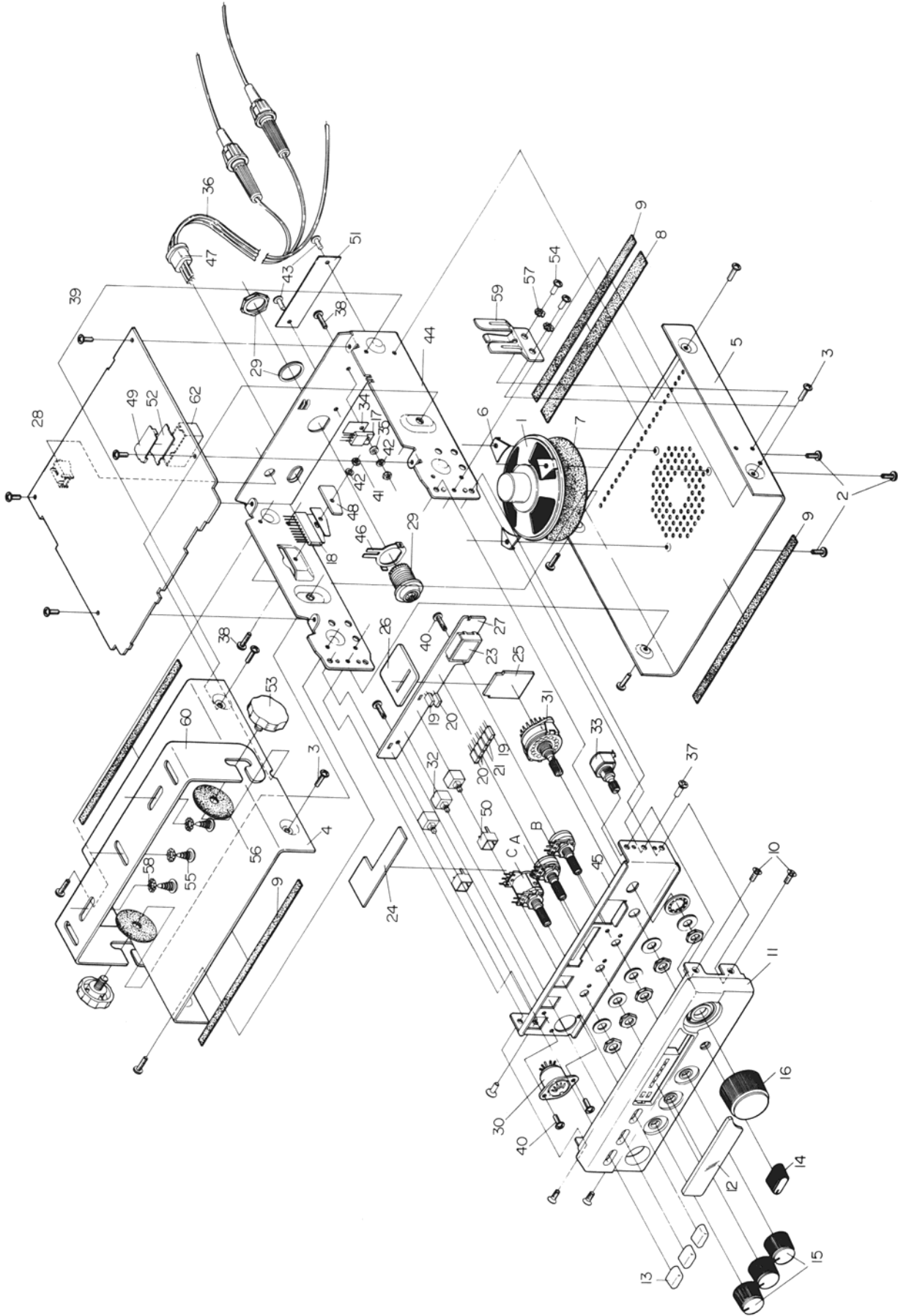

Model 41 PLUS Exploded View Parts List

No.	Part-Symbol	Description
1	420-102-9	Speaker
4	715-721	Cover-Upper
5	715-732	Cover-Bottom
11	801-225	Escutcheon
12	813-721	Lens
13	825-590	Knob-Push, Dark Gray
14	825-595	Knob-Weather, Dark Gray
15	825-601	Knob-Control, Dark Gray
16	825-601	Knob-Channel, Dark Gray
17	204-010-1	Transistor 2SC2078(E)
18	222-006-4	IC KIA7217AP
19	251-141-4	LED Lamp, RED
20	251-142-5	LED Lamp, GRN
21	251-143-6	LED Lamp, AMB
23	251-062-3	LED Display
28	420-707-6	Jack Earphone
29	421-046-7	Connector
30	421-529-7	Socket, 5 Pin
31	430-042-1	Rotary Switch
32	436-008-1	Tact Switch
33	439-016-3	Self Return Switch
36	504-507	Power Cord Ass'y.
51	795-013	Name Plate, ALP3 18X70Xt0.4
53	600-051	Securing Screw, M6X9, BLK
60	723-050	Bracket (SET MTG), SPC t1.6, BLK
A	450-424-9	Resistor Variable (VR), K161100-10KB
B	450-621-0	Resistor Variable (VR), K161100-50KB
C	450-622-1	Resistor Variable (VR), K161100-5M1112-50KA

PARTS LIST 41 PLUS

PARTS LIST 41 PLUS

SYMBOL	DESCRIPTION	PART NO.	SYMBOL	DESCRIPTION	PART NO.
	SPEAKER 3" 8 OHM 2W	580 005 N 001	IC1	I.C. LC7185	308 025 N 001
	COVER UPPER (BURR HOLE) SPC VINYL SHEET 163X222X0.75T	253 004N 001	IC3	I.C. TL489CP	307 426 9 003
	COVER BOTTOM SPC E.S.C. ABS 94HB DARK GRAY SILK	252 008 N 001 380 053 N 001	D6	DIODE ZENER 5.6V	152 157 9 001
	LENS ACRYL CLEAR SILK	753 009 N 001	D25	DIODE ZENER 8.2V (GZA 8.2Y)	152 026 N 001
	KNOB (PUSH) ABS 94HB DARK GRAY	751 016 N 001	D26	DIODE BZX83-C6V2	152 185 9 001
	KNOB (WEATHER) ABS 94HB DARK GRAY	751 016 N 002	D27	DIODE ZENER UZ9.1B	152 125 9 001
	KNOB (CONTROL) ABS 94HB DARK GRAY	751 016 N 003	D30	DIODE VARICAP MV2209	154 009 9 001
	KNOB (CHANNEL) ABS 94HB DARK GRAY	751 017 N 001	D3,4,5,7,8,11,12,13,14,15,17,28,29,31,33,34,36	DIODE SI 1S2473	151 035 9 001
Q32	TRANSISTOR 2SC2078(E)	172 062 9 001	D1,2,10,18,21,23,24	DIODE GE OA90	150 020 9 001
IC2	IC KIA7217AP	307 331 9 001	D22,32,35	DIODE SI 1N4002	151 082 9 001
LED5,6	LED LAMP LTL433P RED	158 008 N 002	X1	CRYSTAL 10.240MHZ HC-18/U	132 036 9 001
LED1,2,8	LED LAMP LTL433A GRN	158 008 N 003	X2	CRYSTAL UNIT HC-49/U 16202MHZ:30PPM	135 009 N 001
LED3,4	LED LAMP LTL433G AMB	158 008 N 001	CF2	CERAMIC FILTER CFU 455HT	143 014 9 001
LED7	LED DISPLAY LTD-482AG-CE	238 002 N 001	CF1	CERAMIC FILTER SFE10.7MJ-M	140 006 9 002
J2	JACK EARPHONE SHQ9384-01-110	773 126 9 001	CH1	TRANSFORMER CHOKE	047 052 9 001
J1	CONNECTOR CH-239(A) SW-1229	777 009 N 001	T1	TRANSFORMER OPT EI-24	061 070 9 001
J3	SOCKET TCS-2250-01-1011 5 PIN	749 116 9 001	RFC8,9	COIL RF CHOKE 20UH CORE	047 039 9 002
SW5	ROTARY S.W. SRM-134 20MM	083 002 N 001	L18	COIL CHOKE 0.25UH SPRING TYPE	047 073 9 003
SW1,2,4	TACT S.W. KPT-2201D	088 008 N 001	RFC5	COIL RF CHOKE 0.5UH SPRING	041 134 9 008
SW3	SELF RETURN S.W. SWK121DHO-5NH-312 WIRING TYP	091 001 N 001	RFC6,7	COIL RF CHOKE 0.8UH SPRING	047 039 9 003
	POWER CORD ASS'Y.	420 002 N 001	RFC12	COIL CHOKE 4UH BOBBIN TYPE	047 012 9 004
	NAME PLATE ALP3 18X70XT0.4	600 007 N 001	L19	COIL AM TX ANT 27MHZ B	046 039 9 013
	SECURING SCREW M6 (P=1) X9 BLK	634 166 9 001	L12	COIL IFT 455KHZ-A	047 049 9 004
	BRACKET (SET MTG) SPC T1.6 BLK SPRAY PICA	250 005 N 001	L13	COIL IFT 455KHZ-B	047 049 9 005
	KNOB (LEVER) ABS 94HB GRAY	384 127 9 001	L8	27MHZ RX ANT	047 039 9 009
CT1,2	CAPACITOR TRIMMER CTC-6U-020:20PF	028 005 N 001	L9,10	27MHZ RF AMP (RX)	047 039 9 010
Q11,12,14,25,26,27	TRANSISTOR KTC1923(O)	176 085 9 001	L11	COIL RF 10.6MHZ 03202926ER(RX)	047 039 9 011
Q18,23,28,33	TRANSISTOR KTC1815(GR)	176 095 9 001	L14	COIL VCO	047 073 9 008
Q3,17,19,20,24,34	TRANSISTOR KTA1015GR	176 057 9 001	L15,16	27MHZ RF PRE AMP A (TX)	047 073 9 009
Q2	TRANSISTOR KTCK161(Y)	182 083 9 001	L17	27MHZ RF PRE AMP B (TX)	047 073 9 010
Q1	TRANSISTOR KTC9018A(H)	176 012 N 001	L2	COIL 160MHZ RX RF	066 003 N 001
Q8,9,10	TRANSISTOR KTC9014A(B)	176 011 N 001	L5	COIL 160MHZ RX OSC1	066 003 N 004
Q4	TRANSISTOR KTC1959(O)	176 013 N 001	L4	COIL 455KHZ RX MIXER	066 003 N 002
Q13	TRANSISTOR KTC1923(Y)	176 014 N 001	L6	COIL 455KHZ RX DET	066 003 N 003
Q21,22	TRANSISTOR MPS9634(C)	176 128 9 001	L7	COIL 27MHZ RX OSC2	066 003 N 005
Q7,29,30	TRANSISTOR MPS9426(C)	176 115 9 001		INSTRUCTION MANUAL	480 004 P 001
Q15,16	TRANSISTOR MPS9623(I)	176 115 9 002			
Q5,6	TRANSISTOR MPS9626(G)	176 150 9 001			
Q31	TRANSISTOR 2SC2314(F)	176 155 9 001			

Block Diagram

