

**This Manual is provided
FREE OF CHARGE from CBTricks.com**

Someone who wanted to help you repair your equipment
scanned this manual.

If you would like to help us put more manuals online support us.

CBTricks.com

CBTricks.com paid for the hosting so you would have this file.

Thank you for any support you can give.



**Cobra 135XLR
40-Channel
Solid State Citizens Band
SSB/AM Two-Way Radio**



The space below is provided to record the Serial Number of this unit. The Serial Number can be found on the back of the product.

Serial No. _____

Retain this information for future reference.

**Cobra Communications Product Group
DYNASCAN CORPORATION
6460 W. Cortland Street
Chicago, Illinois 60635**

INSTRUCTION MANUAL
for
Cobra 135XLR
40-Channel
Citizens Band Solid State
SSB/AM Two-Way Radios



Cobra Communications Product Group
DYNASCAN CORPORATION
6460 W. Cortland Street
Chicago, Illinois 60635

TABLE OF CONTENTS

	Page
SECTION I: Introduction	
Frequency Range	4
FCC Warning	5
SECTION II: Specifications	6
SECTION III: Installation	
Location	9
Base Station Antenna	9
Mobile Operation/Emergency Power Operation	10
Public Address	10
Remote Speaker	10
SECTION IV: Operation	
Controls and Indicators	11
A. Control Functions	11
B. Indicator Functions	13
Operating Procedure to Receive	14
Operating Procedure to Transmit	15
Receiving SSB Signals	15
Alternate Microphones and Installations	17
SECTION V: Maintenance and Adjustment	20
SECTION VI: Appendix	
Ten Code	21
A Few Rules That Should Be Obeyed	22
How Your CB Can Serve You	23
Use Channel 9 For Emergency Messages Only	24
Warranty Service Instructions	Cov. 3
Limited 90-Day Warranty	Cov. 3

THE CB STORY

The Citizens Band lies between the shortwave broadcast and 10-meter amateur radio bands, and was established by law in 1949. The Class D two-way communications service was opened in 1959. (CB also includes a Class A business band and Class C remote control frequencies.) Acquiring the Class D license requires no detailed technical or Morse-code knowledge that is required for a "Ham" license.

In March, 1975, the FCC reduced the cost of a CB license from \$20 to \$4. One license can be good for any number of sets used by a given family or business. Once you receive your Class D license for your equipment, anyone may use it.

For example, though the equipment must be licensed to someone over 18 years of age, a child can use the equipment to talk to another child, or an employee can use the equipment as part of his or her routine services. However, final responsibility of legal operation rests with the CB licensee.

NOTE

FCC regulations permit only "transmissions" (one party to another) rather than "broadcasts" (to a wide audience). Thus, advertising is not allowed on CB channels because it is *broadcasting*.

**HAVE
A GOOD DAY
TODAY
AND
A BETTER DAY
TOMORROW!**

Section I

Introduction

FREQUENCY RANGE

The COBRA 135XLR transceiver represents one of the most advanced SSB/AM two-way radios ever designed for use as a Class D station in the Citizens Radio Service. This unit features advanced Phase Lock Loop (PLL) circuitry which is used in the AM mode and in the upper and lower single sideband modes, providing complete coverage of all 40 channels shown below.

Channel Frequency		Channel Frequency	
Channel	in MHz	Channel	in MHz
1	26.965	21	27.215
2	26.975	22	27.225
3	26.985	23	27.255
4	27.005	24	27.235
5	27.015	25	27.245
6	27.025	26	27.265
7	27.035	27	27.275
8	27.055	28	27.285
9	27.065	29	27.295
10	27.075	30	27.305
11	27.085	31	27.315
12	27.105	32	27.325
13	27.115	33	27.335
14	27.125	34	27.345
15	27.135	35	27.355
16	27.155	36	27.365
17	27.165	37	27.375
18	27.175	38	27.385
19	27.185	39	27.395
20	27.205	40	27.405

The COBRA 135XLR has a vastly superior receiver which includes RF gain control, automatic noise limiting, and noise blanker circuitry which is effective in both AM and SSB modes. The receiver also features increased protection against cross modulation and strong adjacent channel signals.

To obtain maximum performance from your transceiver, please read carefully the following descriptions and operating instructions.

FCC WARNING*

1. Operation of this equipment requires a valid Station License issued by the Federal Communications Commission. Do not transmit with your equipment until you have received your License. Illegal operation can result in severe penalties. Be certain you have read Part 95 of the FCC Rules and Regulations, before operating your station.
2. License applications are to be made on FCC Form 505, available from your nearest field office. (A copy of this form is included with your new COBRA transceiver.)
3. You are required to maintain a current copy of Part 95 of the FCC Rules, as part of your Station records. Copies of Part 95 are available from the Superintendent of Documents, GPO, Washington, D.C. 20402.
4. Your Station License is to be posted in accordance with paragraph 95.101 of the Rules and an executed Transmitter Identification Card (FCC Form 452-C) is to be attached to each transmitter. (A copy of this form also is included with your new COBRA transceiver.)
5. FCC Rules require that ALL transmitter adjustments other than those supplied by the manufacturer as front panel operating controls, be made by, or under the supervision of, the holder of an FCC-issued 1st or 2nd Class Radio Operator License.
6. Replacement or substitution, of crystals, transistors, regular diodes or any other part of a unique nature, with parts other than those recommended by Dynascan, may cause violation of the technical regulations of Part 95 of the FCC Rules, or violation of the Type Acceptance requirements of Part 2 of the Rules.

*Excerpted from Part 95 of the FCC Rules and Regulations.

Section II

Specifications

GENERAL

Channels	40 AM, 40 LSB, 40 USB.
Frequency Range	26.965 to 27.405 MHz.
Frequency Control	Phase Lock Loop (PLL) synthesizer.
Frequency Tolerance	0.005%.
Frequency Stability	0.001%.
Operating Temperature Range	-30°C to +50°C.
Microphone	Plug-in dynamic; with push-to-talk switch and coiled cord.
Power Consumption (120VAC)	<i>Transmit:</i> Full mod., 88 watts. <i>Receive:</i> Squelched, 45 watts.
Current Drain (13.8VDC)	<i>Transmit:</i> AM full mod., 3A; SSB, 12 watts PEP output, 2.8A. <i>Receive:</i> Squelched, .5A; full audio output, 1.5A.
Size	5.12"H, 13.39"W, 11.73"D.
Weight	14.3 lbs.
Antenna Connector	UHF, SO239.
Meters	Shows relative power output, received signal strength, modulation percentage and SWR.
Semiconductors	50 transistors, 5 integrated circuits, 76 diodes and 1 red and 1 numbered light-emitting diode.

TRANSMITTER

Power Output	AM, 4 watts. SSB, 12 watts PEP.
Modulation	AM, high and low-level Class B.
Intermodulation Distortion	SSB: 3rd order, more than -25 dB. 5th order, more than -35 dB.
SSB Carrier Suppression	More than -40 dB.
Unwanted Sideband	More than -40 dB.
Frequency Response	AM and SSB: 350 to 2500 Hz.
Output Impedance	50 ohms, unbalanced.
SSB Filter	7.8 MHz, crystal lattice type: 6 dB @ 4.2 KHz. 60 dB @ 7.0 KHz.
Output Indicators	Meters show relative RF output power and SWR.

RECEIVER

Sensitivity	SSB: Less than .25 μ V for 10 dB (S+N)/N at greater than ½-watt of audio output. AM: Less than .5 μ V for 10 dB (S+N)/N at greater than ½-watt of audio output.
Selectivity	SSB and AM: 6 dB @ 3.8 KHz, 50 dB @ 10 KHz.
Cross Modulation	More than 55 dB.
Image Rejection	More than 50 dB.
IF Frequency Adjacent Channel Rejection	AM and SSB: 7.8 MHz. AM: -65 dB; SSB: -70 dB.
AM and SSB RF Gain Control	Adjustable for optimum signal reception.
Automatic Gain Control (AGC)	Less than 12 dB change in audio output for inputs from 10 to 500,000 microvolts.

Squelch	Adjustable; threshold less than $.5 \mu\text{V}$.
Noise Blanker	RF type, effective on AM and SSB.
Voice Lock Range	AM, $\pm 1.5 \text{ KHz}$, SSB, $\pm 1 \text{ KHz}$.
Audio Output Power	3 watts into 8 ohms.
Frequency Response	350 to 2500 Hz.
Distortion	Less than 10% at 4 watts output.
Built-in Speaker	8 ohms.
External Speaker (Not Supplied)	8 ohms; disables internal speaker when connected.
Input Voltage	120VAC 60 Hz nominal, 132VAC maximum and 108VAC minimum. 13.8VDC nominal, 15.9VDC maximum and 11.7VDC minimum (positive or negative ground).

PA SYSTEM

Power Output	3 watts into external speaker.
External Speaker for PA (Not Supplied)	8 ohms.

Section III

Installation

LOCATION

Plan the location of the COBRA 135XLR transceiver before installation. Installation is a fairly simple procedure.

In selecting the location for the unit, two basic factors must be considered:

1. Access to a 120V, 60 Hz power source.
2. The location must be convenient for running the antenna lead-in cable to the transceiver, if an outside antenna installation is proposed.

BASE STATION ANTENNA

Since the maximum allowable power output of the transmitter is limited by the FCC, the antenna is one important factor affecting transmission distance. Only a properly matched antenna system will allow maximum power transfer from 50-ohm transmission line to the radiating element. Most quality antennas previously suitable for use on AM also will be satisfactory for SSB. Due to the nature of an SSB transmitter, the VSWR must be kept below 2:1 or instability of the final amplifier might occur.

The recommended method of antenna tuning is to use an in-line watt-meter or VSWR bridge to adjust the antenna for minimum reflected power on channel 21 in the AM mode. When the antenna system is adjusted for proper matching in the AM mode, no further adjustment for SSB will be necessary.

The radio may be used with any type of 50-ohm base station antenna. A ground plane vertical antenna will provide the most uniform horizontal coverage.

For point-to-point operation where both stations are fixed, a directional beam will usually increase communications range since this type of antenna concentrates transmitted energy in one direction. The beam antenna also allows the receiver to "listen" in only one direction thus reducing interfering signals.

Antenna height is an important factor when maximum range is desired. Keep the antenna clear of surrounding structures or foliage. FCC regulations limit antenna height to 20 feet above an existing structure.

MOBILE OPERATION/EMERGENCY POWER OPERATION

It is possible to operate the COBRA 135XLR from an external 13.8 VDC power supply for emergency power conditions or from an automobile battery for mobile operation. The COBRA 135XLR is supplied with a polarized plug for operation on external DC supply.

The plug is coded as follows:

Negative lead is gray with a black stripe.

Positive lead is gray and has the in-line fuse holder as an integral part of the positive lead.

PUBLIC ADDRESS

An external 8 ohm, 4 watt speaker may be connected to the PA speaker jack located on the rear panel when the transceiver is used as a public address system. The speaker should be directed away from the microphone to prevent acoustic feed-back. Physical separation or isolation of the microphone and speaker must be used when operating the PA at high output levels.

REMOTE SPEAKER

The external speaker jack (EXT. SPKR.) on the rear panel is used for remote receiver monitoring. The external speaker should have 8 ohms impedance and be able to handle at least 4 watts.

When the external speaker is plugged in, the internal speaker is disconnected.

Section IV Operation

CONTROLS AND INDICATORS

There are fifteen controls and four indicators on the front panel of your COBRA 135XLR.



A. CONTROL FUNCTIONS

OFF/ON. Press down to apply power to the unit.

VOLUME. During normal CB operation, the VOLUME control is used to adjust the output level obtained either at the transceiver speaker or the external speaker, if used.

AUTO ON/OFF. The clock automatically turns the unit on.

SQUELCH. This control is used to cut off or eliminate receiver background noise in the absence of an incoming signal. For maximum receiver sensitivity it is desired that the control be adjusted only to the point where the receiver background noise or ambient background noise is eliminated. Turn fully counterclockwise then slowly clockwise until the receiver noise disappears. Any signal to be received must now be slightly stronger than the average received noise. Further clockwise rotation will increase the threshold level which a signal must overcome in order to be heard. Only strong signals will be heard at a maximum clockwise setting.

RF GAIN CONTROL. Used to reduce the gain of the RF amplifier under strong signal conditions.

SWR CONTROL. Used to calibrate the meter for SWR (standing wave ratio) measurements. Simply switch FWD, press the PTT switch on the microphone and calibrate the meter. Then switch to “REV” to measure SWR. When this control is switched fully counterclockwise, the meter will measure relative RF power output.

DYNAMIKE Adjusts the microphone gain in the transmit and PA modes. This controls the gain to the extent that full talk power is available several inches away from the microphone. In the Public Address (PA) mode the control functions as the volume control.

VOICE LOCK. For normal operation set the control to the center position. This feature has several uses and can greatly enhance receiver operation. First, if a received signal is slightly off frequency, the VOICE LOCK control can be operated as required to optimize the received signal level. The effectiveness of the VOICE LOCK feature under these conditions can be observed either by listening for a more readable signal at the speaker or by noting the S-meter reading when the VOICE LOCK control is operated. Another effective application of this control is in eliminating adjacent channel interference. If it is verified that an exceptionally high level signal from an adjacent channel is creating interference on the channel being used, the VOICE LOCK can be used to minimize or eliminate the interference. Operate the control as required to obtain minimum adjacent channel interference.

CHANNEL SELECTOR. This switch selects any one of forty Citizens Band channels desired. The selected channel appears on the LED readout next to the Channel Selector knob. Channel 9 has been reserved by the FCC for emergency communications involving the immediate safety of life of individuals or immediate protection of property. Channel 9 may also be used to render assistance to a motorist.

FWD/REV SWITCH. Used to calibrate the SWR meter and shows the standing wave ratio (SWR) on the meter when in the REV position. When measuring SWR, place mode switch in the AM position.

OFF/ANL + NB SWITCH. When the switch is placed in the ANL + NB position, the RF noise blanker and the automatic noise limiter in the audio circuits are activated. The RF noise blanker is very effective for repetitive impulse noise such as ignition interference.

PA/CB SWITCH. Selects the mode of operation. In the CB position, the PA function is disabled and the unit will transmit and receive on the selected frequency. *The PA function should not be used unless a PA speaker is connected.*

To use this PA feature, a speaker having a voice coil impedance of 8 ohms and a power handling capability of at least three watts should be used. This speaker must be plugged into the PA SPKR jack at the rear of the transceiver. If the public address feature is to be used primarily for outdoor applications, the use of a weatherproof horn type public address speaker is recommended. The durability of this type speaker plus the inherent efficiency of such a speaker will provide more than adequate results when combined with the high audio output level available from the COBRA 135XLR. With the PA speaker connected as outlined previously, be sure that there is physical separation between the microphone and the speaker itself. If the speaker is located close to the microphone, acoustic feedback will result when the public address system is operated at high volume. A directional type outdoor speaker reduced the amount of isolation required. Some experimentation will determine the minimum amount of isolation required for a given sound level from the public address system.

NOTE

PA volume is controlled by adjusting the DYNAMIKE knob to the desired volume.

B. INDICATOR FUNCTIONS

S-METER. Swings proportionally to the strength of the incoming signal.

RF METER. Swings proportionally to the RF output power. When transmitting, the SWR control must be switched fully counterclockwise to measure RF output.

SWR METER. Swings proportionally to the ratio of standing wave voltage and RF output. Used to properly adjust the length of the antenna, and to monitor the quality of the coaxial cable and all RF electrical connections.

If there is any degradation whatsoever in any of the above, due to humidity, salt spray, vibration or corrosion, the SWR meter reading will rise, thereby indicating that a problem exists.

To calibrate, switch to the FWD position, transmit by pressing the mike switch, and adjust the SWR control to the "CAL" mark on the meter then switch to REV position for the SWR measurement.

CHANNEL INDICATOR. Numbered LED indicates the selected channel you wish to operate on.

TRANSMIT INDICATOR. The red LED located above the channel selector is a proportional output indicating device. When the transmitter is keyed, the LED will light at a reduced intensity, and will brighten as the transmitter is modulated. The first brightness level is indicative of the AM carrier output strength and full brightness is achieved when voice modulation is applied to the carrier since the carrier peak output is increased with modulation.

PRESS-TO-TALK MICROPHONE. The receiver and transmitter are controlled by the press-to-talk switch on the microphone. Press the switch and the transmitter is activated; release switch to receive. When transmitting, hold the microphone two inches from the mouth and speak clearly in a normal "voice". The radios come complete with a low-impedance (500 ohm) dynamic microphone. For installation instructions on other microphones, see next section, "ALTERNATE MICROPHONES AND INSTALLATION."

OPERATING PROCEDURE TO RECEIVE

1. Place the CB/PA switch in the CB position.
2. Turn the set ON by pressing the power OFF/ON switch, until a click is heard.
3. Set the VOLUME for a comfortable listening level.
4. Set the Channel Selector switch to the desired channel.

5. Set the RF GAIN fully clockwise.
6. Set the VOICE LOCK control to the center position.
7. Listen to the background noise from the speaker. Turn the SQUELCH control slowly clockwise, until the noise JUST disappears. (No signal should be present). Leave the control at this setting. The SQUELCH is now properly adjusted. The receiver will remain quiet until a signal is actually received. Do not advance the control too far, or some of the weaker signals will not be heard.

OPERATING PROCEDURE TO TRANSMIT

1. Select the desired channel of transmission.
2. Set the DYNAMIKE control fully clockwise.
3. If the channel is clear, depress the push-to-talk switch on the microphone and speak in a normal voice. The output lamp will light, indicating proportional output power.

CAUTION

Be sure the antenna is properly connected to the unit before transmitting. Prolonged transmitting without an antenna or with a poorly matched antenna (high SWR, over 3) can cause damage to the transmitter.

RECEIVING SSB SIGNALS

There are three types of signals presently used for communications in the Citizens Band: AM, USB, and LSB. When the MODE switch on your unit is placed in the AM position, only standard double-sideband, full carrier signals will be detected. An SSB signal may be recognized while in the AM mode by its characteristic "Donald Duck" sound and the inability of the AM detector to produce an intelligible output. The USB and LSB modes will detect upper sideband and lower sideband respectively, and standard AM signals.

SSB reception differs from standard AM reception in that the SSB receiver does not require a carrier or opposite sideband to produce an intelligible signal. A single-sideband transmitted signal consists only of the upper or the lower sideband and no carrier is transmitted. The elimination of the carrier from the AM signal helps to eliminate the biggest cause of whistles and tones heard on channels which make even moderately strong AM signals unreadable. Also, SSB takes only half of an AM channel, therefore two SSB conversations will fit into each channel, expanding the 40 AM channels to 80 SSB channels. The reduction in channel space required also helps in the receiver because only *half* of the noise and interference can be received with 100% of the SSB signal.

An SSB signal may be received only when the listening receiver is functioning in the same mode. In other words, an upper sideband signal (USB) may be made intelligible *only* if the receiver is functioning in the USB position.

If a lower sideband (LSB) signal is heard when the receiver is in the USB mode, no amount of tuning will make the signal intelligible. The reason for this may be understood if you consider that when modulation is applied to the transmitter's microphone in the USB mode, the transmitter's output frequency is increased whereas in the LSB mode the transmitter's output frequency is decreased. The result in listening to the receiver is that when the MODE switch is in the proper position (either USB or LSB), a true reproduction of signal tone of modulation will result, and if the tone is increased in frequency (such as a low-pitched whistle to a high-pitched whistle) you will hear the increase in the output tone of the receiver. If the incorrect mode is selected, an increase in tone of a whistle applied to the transmitter will cause a decrease in the resultant tone from the receiver.

Thus when a voice is used in place of a whistle or tone, in the proper listening mode the voice will be received correctly whereas in the incorrect mode, the voice will be translated backwards and cannot be made intelligible by the voice lock control. When listening to an AM transmission, a correct sideband is heard in either mode since both upper and lower sideband are received.

Once the desired SSB mode has been selected, frequency adjustment may be necessary in order to make the incoming signal intelligible. The VOICE LOCK control allows the operator to vary frequency above and below the exact-center frequency of the received signal. If the sound of the incoming signal is high or low pitched, adjust the operation of the VOICE LOCK. Consider it as performing the same function as a phonograph speed control. When the speed is set too high, voices will be high-pitched and if set too low, voices will be

low-pitched. Also, there is only *one* speed that will make a particular record produce the same sound that was recorded. If the record is played on a turntable that rotates in the wrong direction (opposite sideband) no amount of speed control (VOICE LOCK) will produce an intelligible sound.

An AM signal received while listening in one of the SSB modes will produce a steady tone (carrier) in addition to the intelligence, unless the SSB receiver is tuned to exactly the same frequency by the VOICE LOCK control. For simplicity it is recommended that the AM modes be used to listen to AM signals.

ALTERNATE MICROPHONES AND INSTALLATION

For best results, the user should select a low-impedance dynamic type microphone or a transistorized microphone. Transistorized type microphones have a low output impedance characteristic. The microphones must be provided with a four-lead cable. The audio conductor and its shielded lead comprise two of the leads. The third lead is for the transmit control and the fourth lead is ground (see schematic, Fig. 3). The microphone should provide the functions shown below:

4-Wire Mic Cable

Pin Number	Mic Cable Lead
1	Audio Shield
2	Audio Lead
3	Transmit Control
4	Ground

If the microphone to be used is provided with pre-cut leads, they must be revised as follows:

1. The leads should be cut so that they extend 7/16" beyond the plastic insulating jacket of the microphone cable. See Fig. 1 below.
2. All leads should be cut to the same length. Strip the ends of each wire 1/8" and tin the exposed wire.

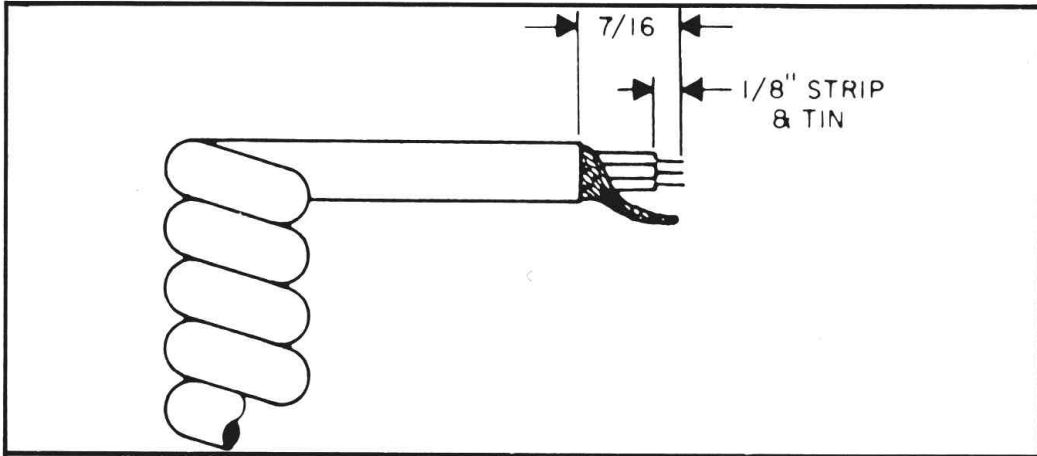

Fig. 1. Microphone cable preparation.

Before beginning the actual wiring, read carefully the circuit and wiring information provided with the microphone you select. Use the minimum heat required in soldering the connections. Keep the exposed wire lengths to a minimum to avoid shorting when the microphone plug is reassembled.

To wire the microphone cable to the plug provided, proceed as follows (see Fig. 2):

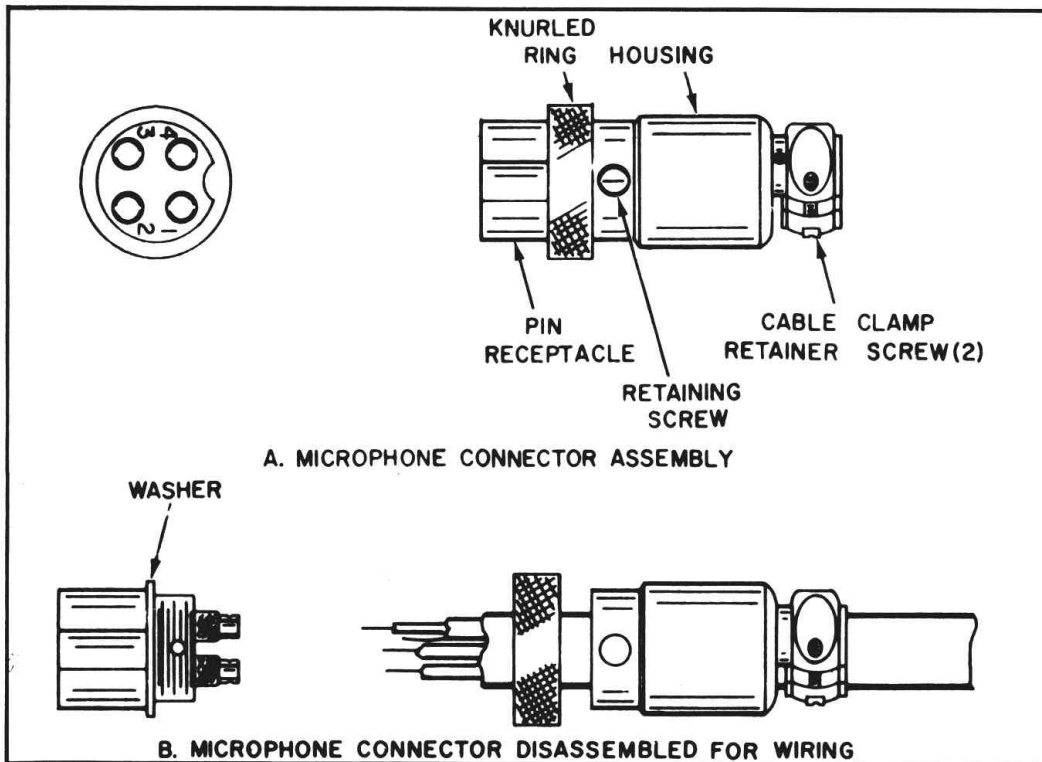

Fig. 2. Microphone plug wiring.

1. Remove the retaining screw.
2. Unscrew the housing from the pin receptacle body.
3. Loosen the two cable camp retainer screws.
4. Feed the microphone cable through the housing, knurled ring and washer below.

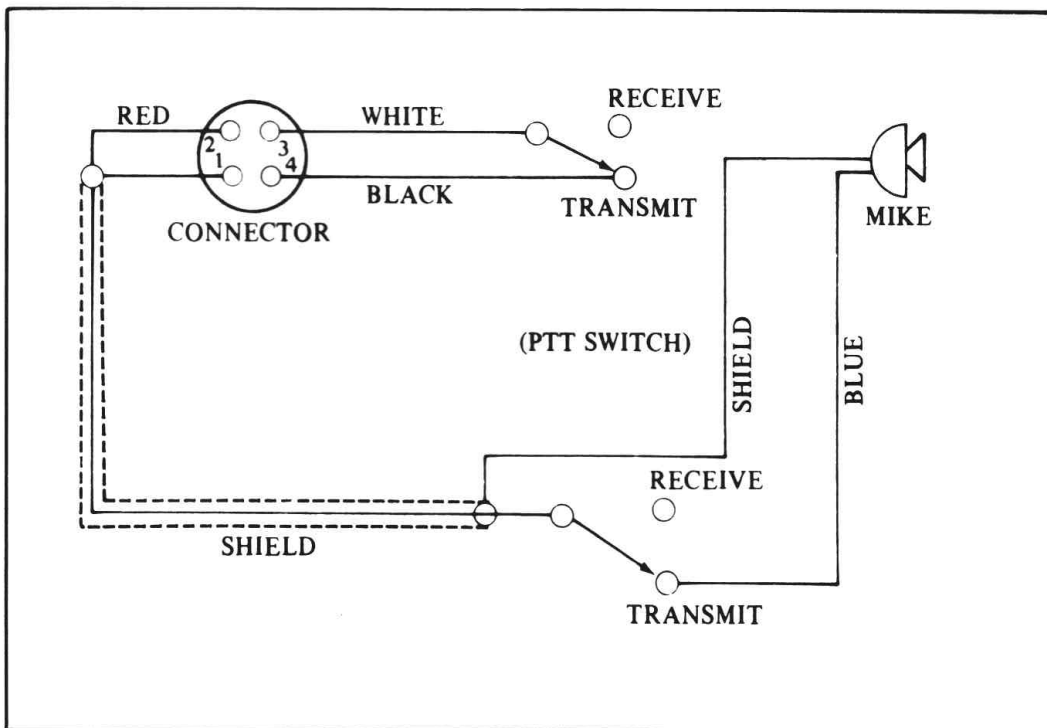

Fig. 3. Microphone and connector wiring diagram.

Section V

Maintenance and Adjustment

The COBRA 135XLR transceiver is specifically designed for the environment encountered in mobile installations. The use of all solid state circuitry and its light weight result in high reliability. Should a failure occur, however, replace parts only with identical parts. Do not substitute. Refer to the schematic diagram and parts list.

NOTE

If the performance described in the OPERATION and MAINTENANCE AND ADJUSTMENT sections is not obtained, review the operating instructions to insure that proper procedures were followed. If a problem still exists, refer to WARRANTY SERVICE INSTRUCTIONS elsewhere in this manual.

FCC WARNING

Federal law requires that adjustment of the radio frequency section of this transceiver may not be made by a Citizens Band operator. Only a United States licensed First or Second Class commercial license holder may tune the transmitter section of this transceiver, per FCC part 95 section 95.97d.

Section VI

Appendix

Citizens Band radio operators have largely adopted the “10-code” for standard questions and answers. Its use permits faster communications and better understanding in noisy areas. The following table lists some of the more common codes and their meanings.

10 CODE

Code	Meaning	Code	Meaning
10-1	Receiving poorly	10-29	Time is up for contact
10-2	Receiving well	10-30	Does not conform to FCC rules
10-3	Stop transmitting	10-32	I will give you a radio check
10-4	OK, message received	10-33	EMERGENCY TRAFFIC
10-5	Relay message	10-34	Trouble at this station
10-6	Busy, stand by	10-35	Confidential information
10-7	Out of service, leaving air	10-36	Correct time is
10-8	In service, subject to call	10-37	Wrecker needed at
10-9	Repeat message	10-38	Ambulance needed at
10-10	Transmission completed, standing by	10-39	Your message delivered
10-11	Talking too rapidly	10-41	Please turn to channel
10-12	Visitors present	10-42	Traffic accident at
10-13	Advise Weather/Road conditions	10-43	Traffic Tie up at
10-16	Make pick up at	10-44	I have a message for you
10-17	Urgent business	10-45	All units within range please report
10-18	Anything for us?		
10-19	Nothing for you, return to base	10-50	Break channel
10-20	My location is	10-60	What is next message number?
10-21	Call by telephone	10-62	Unable to copy, use phone
10-22	Report in person to	10-63	Net directed to
10-23	Stand by	10-64	Net clear
10-24	Completed last assignment	10-65	Awaiting your next message/assignment
10-25	Can you contact	10-67	All units comply
10-26	Disregard last information		
10-27	I am moving to channel	10-70	Fire at
10-28	Identify your station		

10 CODE (Continued)

Code	Meaning	Code	Meaning
10-71	Proceed with transmission in sequence	10-91	Talk closer to mike
10-73	Speed trap at	10-92	Your transmitter is out of adjustment
10-75	You are causing interference	10-93	Check my frequency on this channel
10-77	Negative contact	10-94	Please give me a long count
10-81	Reserve hotel room for	10-95	Transmit dead carrier for 5 seconds
10-82	Reserve room for	10-99	Mission completed, all units secure
10-84	My telephone number is		
10-85	My address is		
10-89	Radio repairman needed at		
10-90	I have TVI	10-200	Police needed at

A FEW RULES THAT SHOULD BE OBEYED

1. You must identify your official licensed call sign at the beginning and end of every conversation.
2. You are not allowed to carry on a conversation with another station for more than five minutes at a time without taking a one-minute break, to give others a chance to use the channel.
3. You are not allowed to blast others off the air by over-powering them with illegally amplified transmitter power, or illegally high antennas.
4. You can't use CB to promote illegal activities.
5. You are not allowed to use profanity.
6. You may not play music in your CB.
7. You may not use your CB to sell merchandise or professional services.

HOW YOUR CB CAN SERVE YOU

- Warn of traffic tie ups ahead.
- Provide weather and road information.
- Provide help fast in event of emergency or breakdown.
- Suggest good spots to eat and sleep.
- Make long trips more interesting, and help keep you awake.
- Provide direct contact with your office or home.
- Make friends for you as you travel.
- Provide “local information” to find your destination.
- Help law enforcement officers by reporting drunk and reckless drivers.

Colonel Samuel S. Smith of the Missouri Highway Patrol called the number of drunken drivers, wrong-way drivers and speeders reported by CBers as “amazing.” He said, that even the “Smokey Bear” warnings don’t shake their beliefs that “the potential benefits of CB radio to law enforcement are so great that they far outweigh the disadvantages.” In regards to CB radar warnings to other CBers, Colonel Smith said cheerfully that “We’ve overheard warnings being relayed to truckers long after our operations have been discontinued . . . so we actually receive a residual benefit from these warnings.”

USE CHANNEL 9 FOR EMERGENCY MESSAGES ONLY

FCC gives the following examples of permitted and prohibited types of communications for use on Channel 9. These are guidelines and are not intended to be all-inclusive.

Permitted	Example Message
Yes	“A tornado sighted six miles north of town.”
No	“This is observation post number 10. No tornado sighted.”
Yes	“I am out of gas on Interstate 95.”
No	“I am out of gas in my driveway.”
Yes	“There is a four-car collision at Exit 10 on the Beltway, send police and ambulance.”
No	“Traffic is moving smoothly on the Beltway.”
Yes	“Base to Unit 1, the Weather Bureau has just issued a thunderstorm warning. Bring the sailboat into port.”
No	“Attention all motorists. The Weather Bureau advises that the snow tomorrow will accumulate 4 to 6 inches.”
Yes	“There is a fire in the building on the corner of 6th and Main Streets.”
No	“This is Halloween patrol unit number 3. Everything is quiet here.”

WARRANTY SERVICE INSTRUCTIONS

1. Refer to the **MAINTENANCE** section of your Cobra instruction manual for adjustments that may be applicable.
2. Defective parts removed from units which are within the 90-Day Limited Warranty period should be sent **PREPAID** to the Service Department listed below. Be sure to state the model and serial number of the unit from which the parts were removed and date the unit was purchased. These parts will be exchanged at no charge, under the terms of the Warranty.
3. If the above-mentioned procedures do not correct the problem you are experiencing with your unit, pack it securely (preferably in the original carton or double-packed). Enclose a letter describing the problem and include your name and address. Deliver to, or ship **PREPAID** (UPS preferred) to the nearest Cobra authorized service agency (see list enclosed with unit).

If your list of authorized Cobra service agencies has been misplaced, contact your local dealer for the name of your nearest service agency, or write to:

Service Department

Cobra Communications Product Group
DYNASCAN CORPORATION
2815 West Irving Park Road
Chicago, Illinois 60618

LIMITED 90-DAY WARRANTY

DYNASCAN CORPORATION warrants to the original purchaser that its COBRA Citizens Band Radios, and the component parts thereof, will be free from defects in workmanship and materials for a period of ninety (90) days from the date of purchase.

DYNASCAN will, without charge, repair or replace, at its option, defective radios or component parts upon delivery to an authorized COBRA service contractor or the factory service department, accompanied by proof of the date of purchase in the form of a sales receipt.

To obtain warranty coverage, this CB radio must be registered by completing and mailing the enclosed warranty registration card to DYNASCAN Cobra Communications, P.O. Box 35148, Chicago, Illinois 60635 within five (5) days from the date of purchase.

Exclusions: This warranty does not apply in the event of misuse or abuse of the product or as a result of unauthorized alterations or repairs. It is void if the serial number is altered, defaced or removed.

As indicated in your product instruction booklet, certain COBRA models are suitable for dash board installation without modification of the dash. In other cases professional installation is recommended. In either event, DYNASCAN is not responsible for damages to the product or the automobile resulting from improper installation.

DYNASCAN shall not be liable for any consequential damages, including without limitation damages resulting from loss of use or cost of installation. Some states do not allow limitation of incidental or consequential damages, so the above limitation or exclusion may not apply to you.

This warranty gives you specific rights and you may also have other rights which vary from state to state.

For your convenience we suggest you contact your dealer, who may be authorized to make repairs or can refer you to the nearest service contractor. If warranty service cannot be obtained locally, please send the unit to Cobra Service, 2815 West Irving Park Road, Chicago, Illinois 60618, properly packaged to avoid damage in shipment.

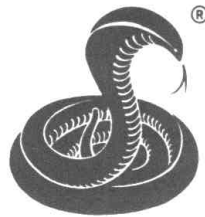

Cobra

Cobra Communications Product Group
DYNASCAN CORPORATION
6460 W. Cortland Street
Chicago, Illinois 60635

480-202-9-001

SZD0048