

TRUCKERS SPECIAL POLARITY PROTECTOR WITH SMARTS!

Never again will you have to go through the agony of hooking your rig up backward. Do this simple modification, and relax.

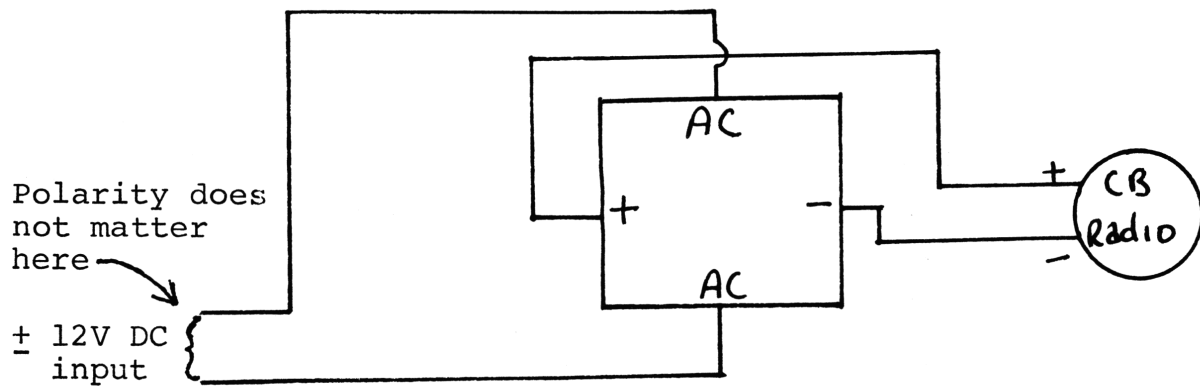

Bridge Rectifier - 25amp, 25 PRV
Mount inside chassis.

One more simple way to protect your "rig".

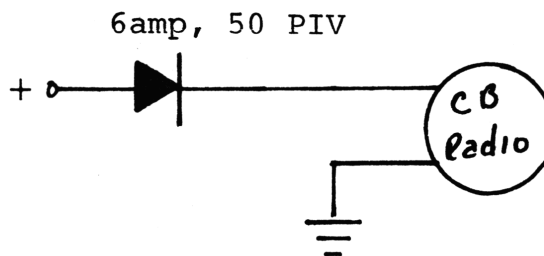

If connected up backwards, nothing will happen due to reverse bias which causes blocking action of diode. When connected properly, diode conducts, and radio will be ON.