

# ASSEMBLY INSTRUCTIONS

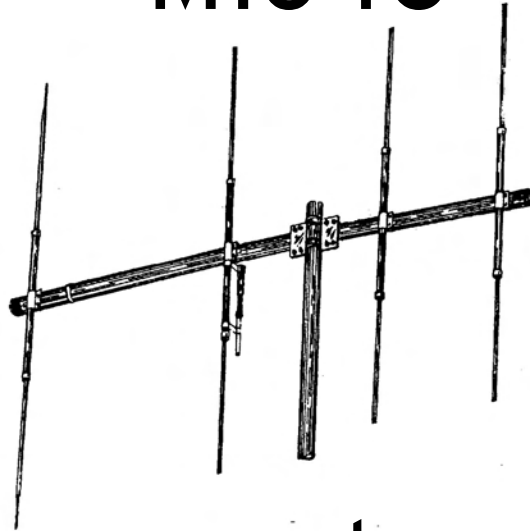

**4 ELEMENT - 11 METER  
MAXIMUM BEAM**

**M104C**



**[www.macoantennas.net](http://www.macoantennas.net)  
(815) 244-3500**

MACo Antennas, A Division of Charles Electronics, LLC  
302 S. East Street, Mt. Carroll, IL 61053

# MACO M104C

## PACKING LIST

<u>PART</u>	<u>QTY</u>	<u>SIZE</u>	<u>LENGTH</u>	<u>DESCRIPTION</u>	<u>CHECKLIST</u>
T41P	1	2"x.060	72"	ALUMINUM TUBING SWAGED BOTH ENDS	_____
T51P	2	2"x.060	72"	ALUMINUM TUBING SLOTTED ONE END	_____
T01	6	1/2"x.050	72"	ALUMINUM TUBING	_____
T05P	2	1/2"x.050	80.5"	ALUMINUM TUBING SLOTTED ONE END	_____
T11P	4	5/8"x.050	72"	ALUMINUM TUBING SLOTTED BOTH ENDS	_____
T58P	2	3/8"x.050	11 7/8"	ALUMINUM TUBING	_____
P02P	1	1/4"x5"	5"	PLATE 2" BOOM TO 2" MAST	_____
G01P	1			GAMMA MATCH	_____
S42	1			COAX CONNECTOR W/MOUNTING NUT	_____
Z08P	2			GAMMA STRAPS WITH F/COAX CONNECTOR	_____

### HARDWARE BAG #1

U01	10	2"		PLATED U-BOLTS	_____
S01	10	2"		PLATED SADDLES	_____
N03	20	5/16"		LOCK NUTS	_____

### HARDWARE BAG #2

BE2P	4	2"		BOOM TO ELEMENT MOUNTS	_____
C02	2	1/2"		METAL CLAMPS	_____
W58	8			EXTRUDED ALUMINUM CLAMPS	_____
N11	13	10-24		SQUARE NUTS	_____
N12	4	#10		LOCK WASHERS	_____
PL1	2	3/8"		PLASTIC CAPS – BLACK	_____
PL2	6	.437		PLASTIC CAPS – BLACK	_____
PL5	1	2"		PLASTIC CAPS – BLACK	_____
PL5R	1	2"		PLASTIC CAP – RED	_____
S21	13	10-24x1/2"		MACHINE SCREWS	_____
Z02P	2			GAMMA STRAPS	_____
	1			TIP SHEET	_____
	1			WARRANTY SHEET	_____
	1			SET OF INSTRUCTIONS	_____

Please note: In an effort to keep the price on Maco Antennas down, we have decided not to clean up all the burrs and rough edges on the parts. We recommend that you deburr and clean up each part with files, sandpaper, etc. so that they go together easily. We are aware this needs to be done but have elected not to do it to save you the money we would have to add to the price of the kit for this service.

# MACO M104C

## ASSEMBLY INSTRUCTIONS

### FIGURE 1 GENERAL INSTRUCTIONS

This drawing shows a view of the antenna assembled. The M104C may be used vertically (Figure 1 A) or horizontally (Figure 1 B). These instructions and FIGURES 2 through 4 show the correct assembly instructions. It is highly recommended that rope be put in the elements to prolong their life. All Hardware should be tightened securely, and then coated with silicon rubber sealant or a similar compound to prevent loosening from wind vibration.

Upon completion of assembly, install the red plastic cap (PL4R) on the director end of the antenna, and the black plastic cap (PL4) on the reflector end. This will allow you to determine at a glance the direction of transmit and receive.

CAUTION.....

Take care to avoid any contact with overhead power lines when raising your antenna. Serious or fatal injury could result.

### FIGURE 2 BOOM ASSEMBLY AND MAST MOUNTING

To assemble the boom, slide the slotted ends of the boom sections (T5 1 P) onto both swaged ends of the center boom section (T4 1 P). The overall length should be about 17 feet. Next center the boom-to-mast plate (P02P) and mount using 2" U-bolts, saddles and hardware as shown in detail 2B.

This antenna is designed for mounting on a 2" O.D. heavy duty mast. Mount using 2" U-bolts, saddles and hardware as shown in detail 2C.

### FIGURE 3 ELEMENT ASSEMBLY AND MOUNTING

To assemble the elements, use (4) of the clamps (W58P) and #10 x 1/2" screw and square nuts (S2 1 ,N 1 1 ) as shown in the element assembly detail. Insert a length of the 1/2" O.D. unslotted tubing (T01P) into each end of the element sections. Adjust each end to the "B" dimensions and tighten the clamps. Check the overall length ("A" dimension). Push a 437" plastic cap (PL2) on each end of the elements.

Mount the elements onto the boom using U-bolts, saddles, and hardware (UO 1, S02, N01, N02) to fasten the boom-to-element clamp (BE 1 P) as shown in the element mounting detail. From the director end of the boom, measure in 5/8" to the outside edge of the mounting hardware and fasten the director. Refer to Figure 1 for the spacing dimensions and fasten the driven element and reflector. Start at about 4" from the end to center the elements on the boom.

Line the elements up with the use of a level or any other workable method. Double check the spacing dimensions and make sure the elements are centered in the boom-to-element clamps. Tighten all hardware taking care to line the elements up with the use of a level. Check your measurements and make sure the elements are centered on the boom.

**TIGHTEN ALL HARDWARES NUG; DONOT CRUSH THE TUBING. CRUSHING GREATLY WEAKENS THE TUBING.**

## ASSEMBLY INSTRUCTIONS

(continued)

### FIGURE 4 GAMMA MATCH MOUNTING

Mount the gamma match (G01P) to the driven element, using the gamma straps (Z02P, Z08P) and attaching hardware as shown. Attach your 52 ohm coaxial cable to the connector (S42) and dress along boom and down the mast. The gamma is shown pointing down - this is to let water out.

### ADJUSTING THE STANDING WAVE RATIO (SWR)

Refer to Figure 4. The dimensions given are approximate and should be used as a starting point. The gamma match has 2 adjustments. First is the capacitor adjust and second is the slider adjust. Connect a SWR bridge coax between your transmitter and the antenna and check the SWR. If adjustment is required, loosen the clamp on the gamma match and the screws holding the slider (gamma straps (Z02P)). Next move the capacitor adjustment first one direction, then the other until a minimum SWR reading is obtained. If SWR is not yet satisfactory, move the slider out 2" away from the boom. If the reading has gone up move the slider back to the original position and then 2" towards the boom. Now readjust the capacitor for minimum SWR. You should now be able to determine which direction to move the slider. Repeat the above procedure moving the slider in smaller increments until a satisfactory SWR is obtained. Tighten all hardware. Disconnect the SWR bridge and reconnect your coaxial cable.

---

#### NOTE!

When assembling for vertical use, set antenna on a pole about 8 to 9 feet above the ground horizontally and adjust SWR for 1.6 to 1.7 When you turn the antenna vertical and mount it on the tower, etc., the SWR will drop to 1.4 to 1.5 This is good; QUIT!

---

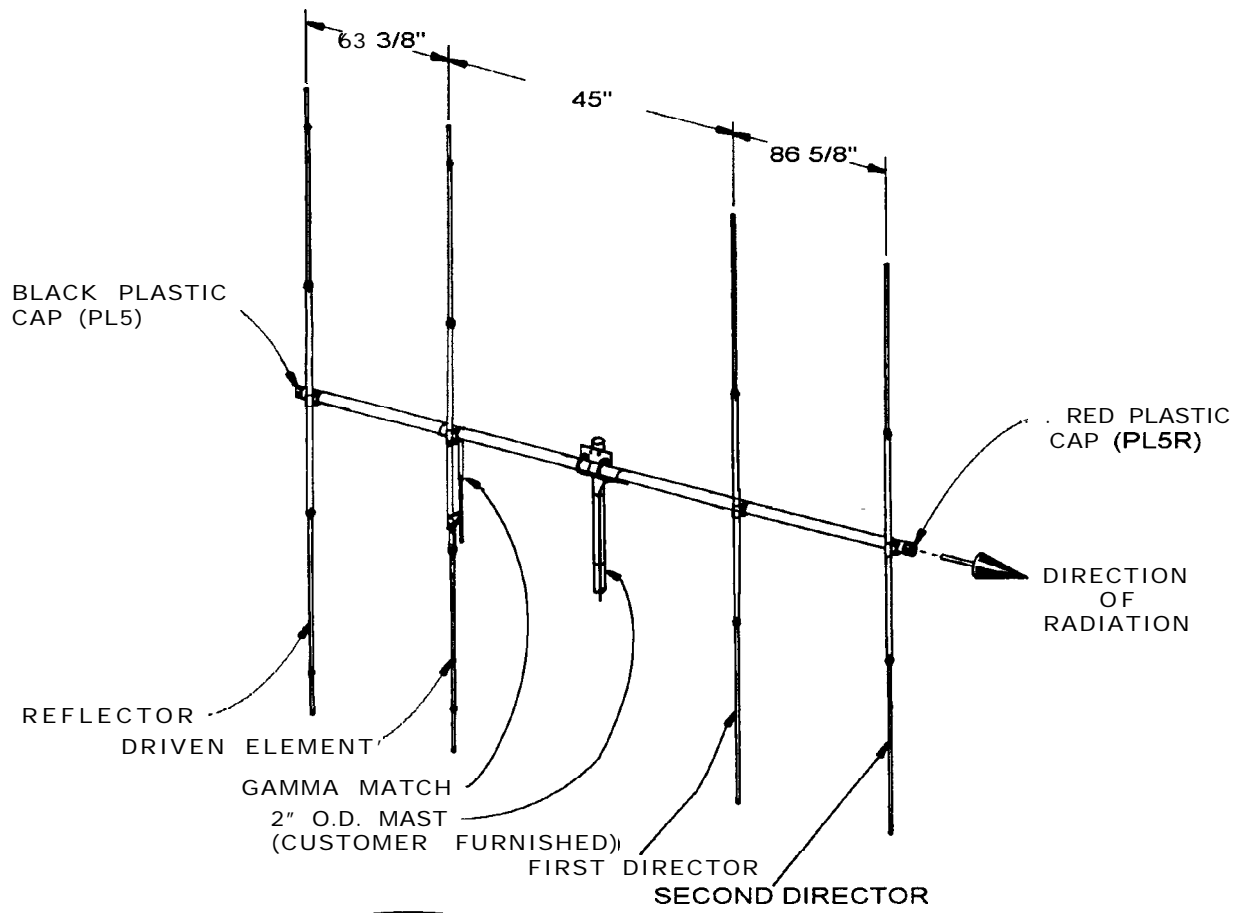

FIGURE 1A VERTICAL POLARIZATION

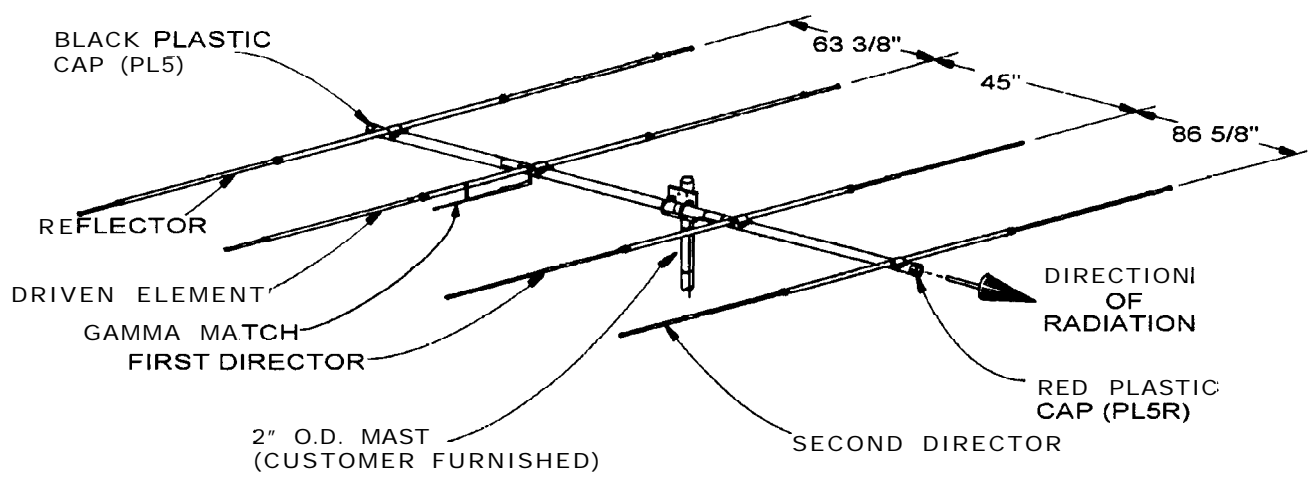
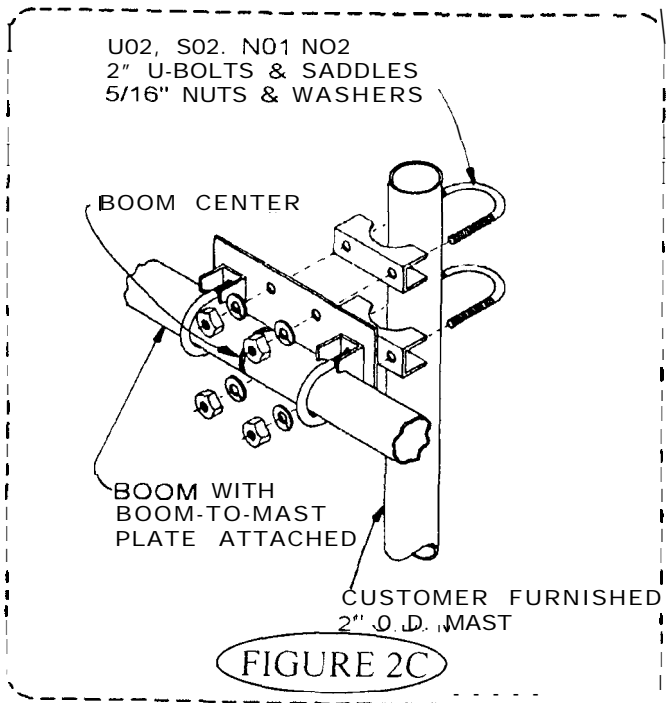
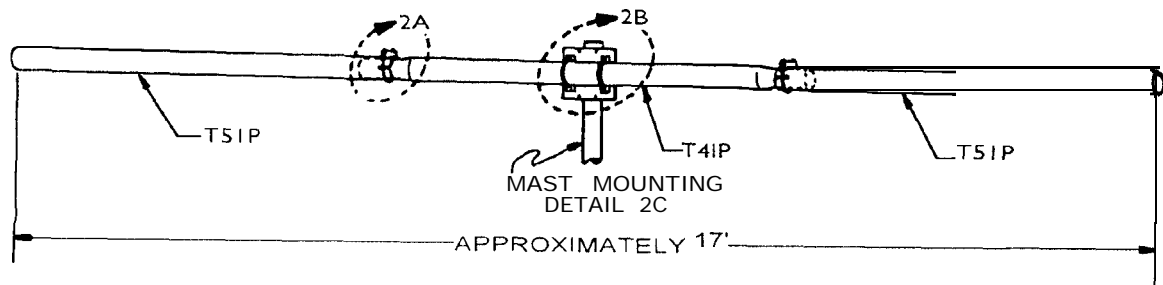
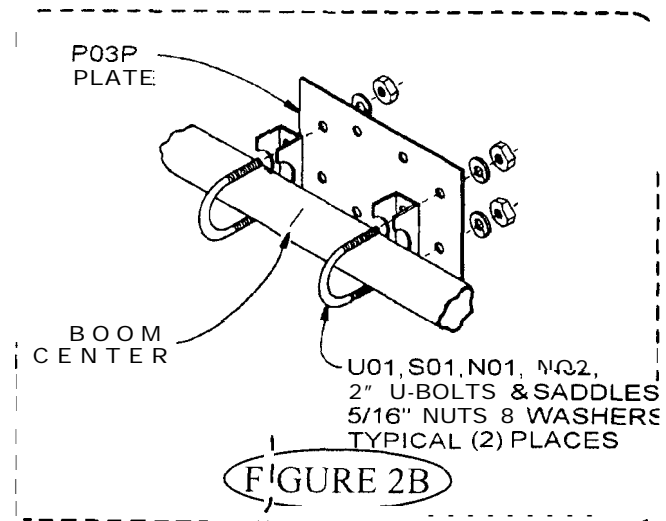
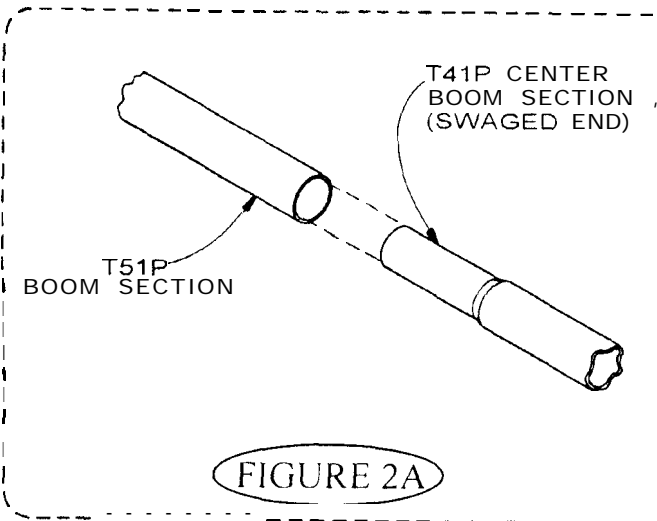

FIGURE 1B HORIZONTAL POLARIZATION

GENERAL ASSEMBLY

EM104C1



BOOM ASSEMBLY  
& MAST MOUNTING

FIGURE 2

M104C

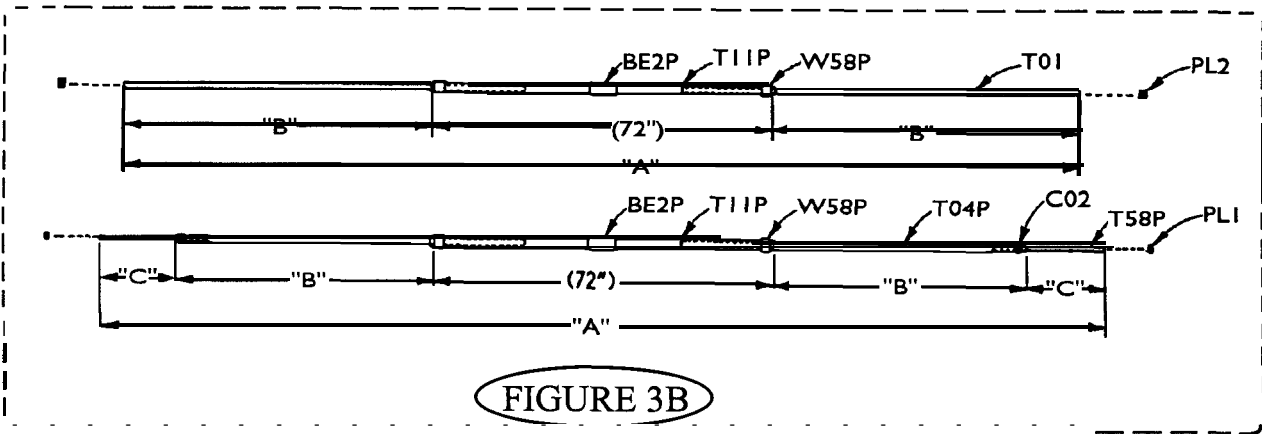

FIGURE 3B

ELEMENT ASSEMBLY  
& MOUNTING

FIGURE 3

DIMENSIONS			
ELEMENT	A	B	C
DRIVER	209"	68 1/2"	
1ST DIRECTOR	204 3/4"	66 3/8"	
2ND DIRECTOR	188 1/2"	58 1/4"	
REFLECTOR	216 3/4"	65 1/2"	6 7/8"

FIGURE 3A

Please read the Assembly and Troubleshooting Tips at the end of this instruction booklet before assembling elements.

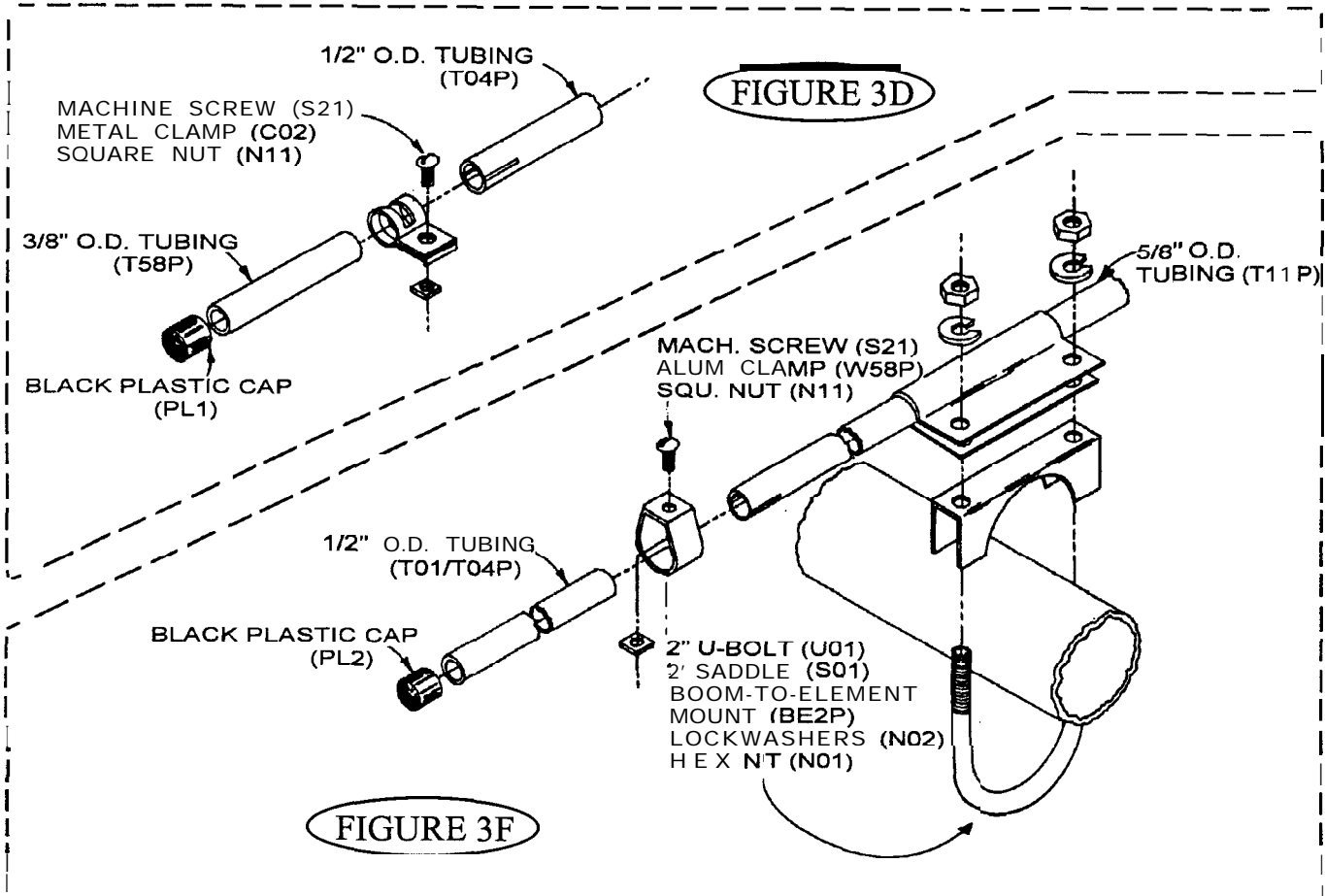
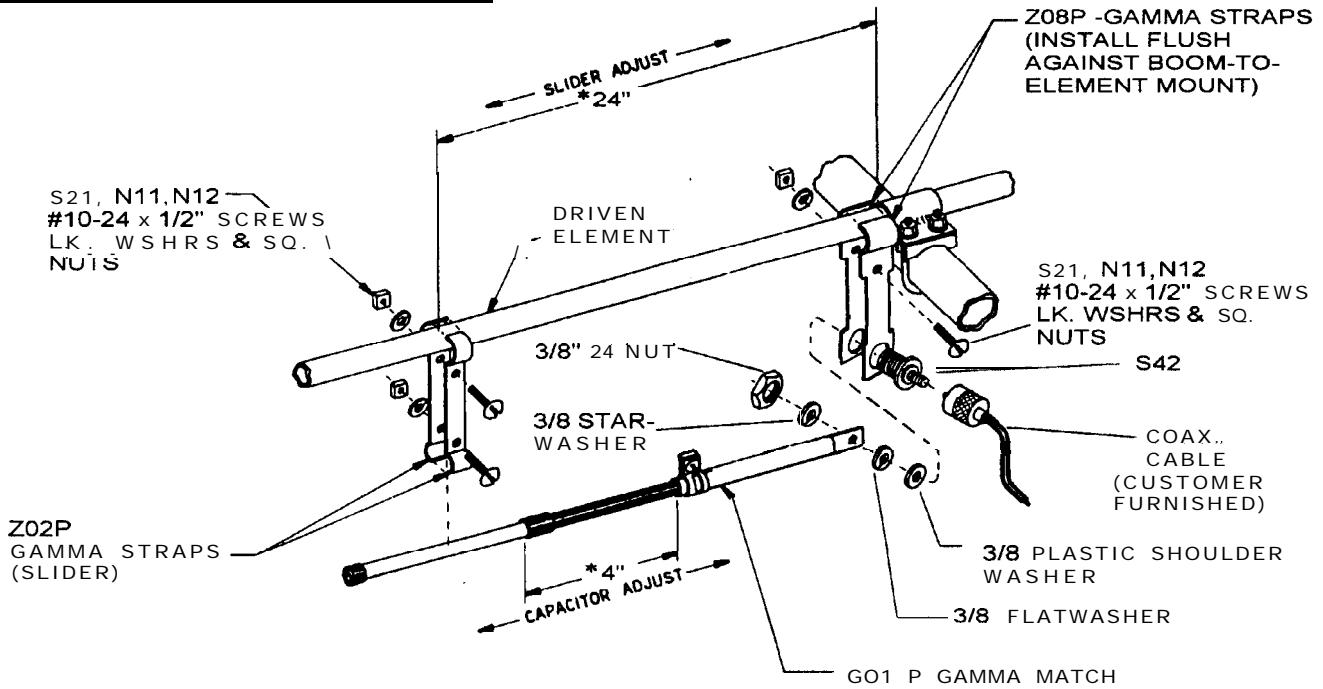

FIGURE 3D

FIGURE 3F

**\* NOTE: THESE DIMENSIONS ARE APPROXIMATE. REFER TO THE INSTRUCTIONS ON ADJUSTING THE S.W.R TO DETERMINE EXACT SETTINGS. THERE ARE 2 SEPARATE GAMMA ADJUSTMENTS, 1. CAPACITOR ADJUSTMENT, 2. SLIDER POSITION. DO NOT MOVE BOTH AT THE SAME TIME. MOVE THE CAPACITOR FIRST, THEN, IF NECESSARY MOVE THE SLIDER, AND GO BACK TO THE CAPACITOR**



GAMMA MATCH MOUNTING

FIGURE 4

M104C

Mount the gamma match (G01P) to the driven element, using the gamma straps (Z02P, Z08P) and attaching hardware as shown. Attach your 52 ohm coaxial cable to the connector (S42) and dress along boom and down the mast. The gamma is shown pointing down - this is to let water out.

ADJUSTING THE STANDING WAVE RATIO (SWR)

Refer to Figure 4. The dimensions given are approximate and should be used as a starting point.\* The gamma match has 2 adjustments. First is the capacitor adjust and second is the slider adjust. Connect a SWR bridge coax between your transmitter and the antenna and check the SWR. If adjustment is required, loosen the clamp on the gamma match and the screws holding the slider (gamma straps (Z02P)). Next move the capacitor adjustment first one direction, then the other until a minimum SWR reading is obtained. If SWR is not yet satisfactory, move the slider out 2" away from the boom. If the reading has gone up move the slider back to the original position and then 2" towards the boom. Now readjust the capacitor for minimum SWR. You should now be able to determine which direction to move the slider. Repeat the above procedure moving the slider in smaller increments until a satisfactory SWR is obtained. Tighten all hardware. Disconnect the SWR bridge and reconnect your coaxial cable.



**DANGER**

**High Voltage  
Overhead**

**Caution:**

**TAKE CARE TO AVOID ANY CONTACT WITH  
OVERHEAD POWERLINES WHEN RAISING,  
INSTALLING, OR REPAIRING YOUR  
ANTENNA, TOWER, OR ROTOR.**

**DEATH WILL OCCUR!**

Installing and rigging towers, masts and antennas require specialized skills and experience. Information supplied by MACo assumes that all products will be installed by personnel having these skills and have installed similar products before. No one should attempt to install towers or masts without these knowledgeable skills.

MACo assumes no liability if faulty or dangerous installation practices are used. There are available, trained and experienced personnel to assist in installation, maintenance, or disassembly. Contact your local installer if consultation or assistance is required.

All tower and antenna installations should be thoroughly inspected at least twice a year by qualified, experienced, and trained personnel to insure proper performance and safety standards.

### Electrical Warning

An additional warning precaution is given to be careful of surrounding high voltage power wires and other electrical hazards during installation of your tower, rotor, or antenna.

Do not erect a tower, rotor, or antenna during an electrical storm, rainstorm, or when lightning is a possibility.



**Danger of  
Death**

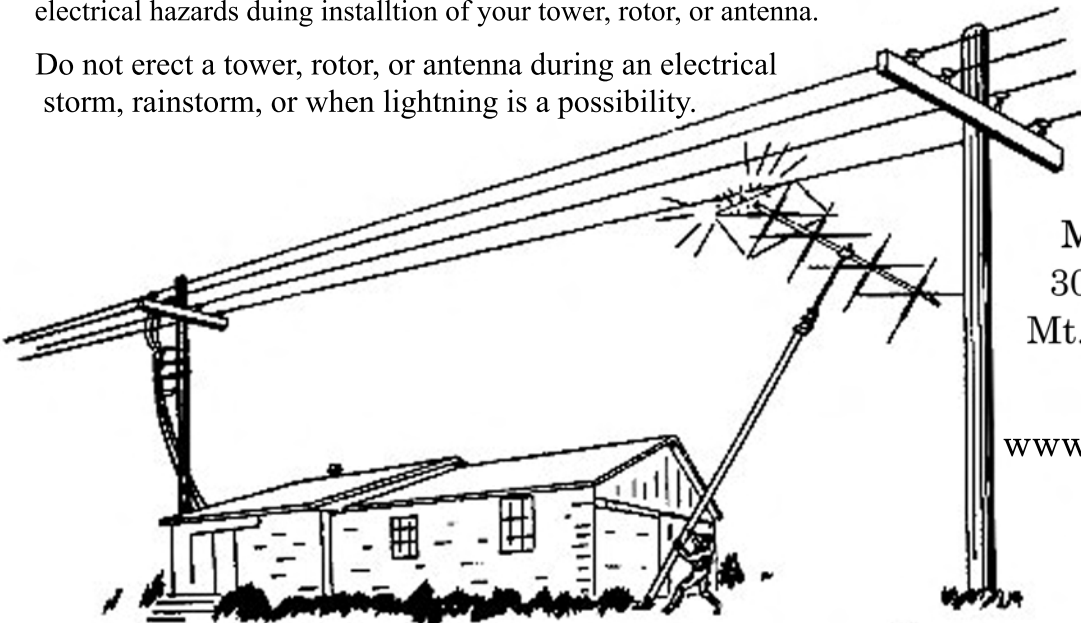

**MACo Antennas  
302 S. East Street  
Mt. Carroll, IL 61053**

[www.macoantennas.net](http://www.macoantennas.net)  
**(815) 244-3500**

**MACo Antennas is a Division of Charles Electronics, LLC**