



TELEX COMMUNICATIONS, INC.
8601 NORTHEAST HIGHWAY SIX, LINCOLN, NE 68505 U.S.A.

INSTRUCTION MANUAL

ORDER NO. 473

Model CLR-2
Base Station Antenna

PN 801286

General Description

The CLR-2 is an omnidirectional, vertically polarized, ground plane antenna. Taper-swaged tubing reduces the wind load and increases its mechanical durability. Maximum legal height provides the largest signal capture area. A top hat and a long radiating element create a full $\frac{1}{4}$ -wave radiator. This achieves the lowest possible angle of radiation by aiming most of the rf energy along the horizon for greater range. The CLR-2 also develops an omnidirectional gain of 4 dB that is 12.55 watts of "Talk Power" for the maximum possible from a single $\frac{1}{4}$ -wave system.

The etched copper p.c.b. base coil and the SO-239 connector are permanently weatherproof in a moistureproof base housing. VSWR is less than 1.2:1. The top hat of the antenna and the DC ground design greatly reduce atmospheric noise and minimize lightning hazards.

Construction

No dissimilar metals are used. Taper-swaged, seamless tubing with full circumference compression fittings decrease the wind load and give added strength to the antenna for no element droop. Slotted tubing makes for easy assembly. The compression clamps insure corrosion proof stability that defies electrical failure and noise caused by loose connections.

The heavily ribbed, heavy gauge metal mast bracket secures the CLR-2 solidly to the mast. A 12" bracket provides two-point support, insuring the CLR-2 will stand erect and secure at all times.

Specifications

Electrical

Gain	4 dB
Power multiplication factor	2.5
SWR (at resonance)	less than 1.2:1
Input impedance	52 ohms
Direction of radiation	omnidirectional

Mechanical

Overall height	19'10" (approx.) (6.04 m)
Diameter of radiator	1 1/4" to 7/16" (3.17 cm to 1.11 cm)
Length of radials	8'6" (2.590 m)
Diameter of radials	5/8" to 7/16" (1.58 cm to 1.11 cm)
Mast bracket accepts	1 1/4" to 1 5/8" (3.17 cm to 4.12 cm)
Net weight	7.8 lbs. (3.53 kg)
Wind survival	75 mph (120.69 kmph)

Schematic Diagram

Figure 1 shows the electrical circuitry of the antenna. Note the radiator is maximum legal height and that radials are full $\frac{1}{4}$ -wavelength for largest possible signal capture aperture. The radiator is more than twice as long as that used for a standard ground plane antenna. The radiator is 2 ft. taller and radials twice as long as those used with most $\frac{1}{2}$ -wavelength end fed antennas.

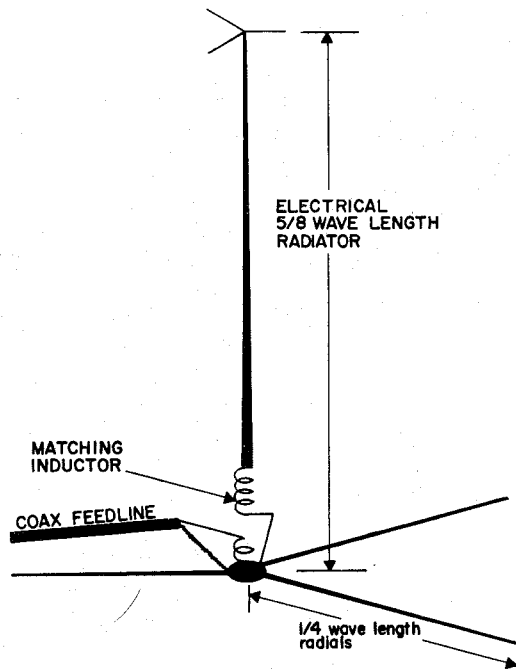

Figure 1

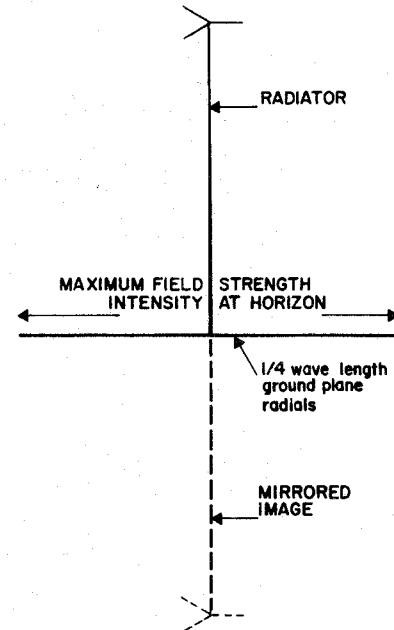

Figure 2

Lowers Angle of Radiation for Maximum Gain

Figure 2 shows how the $\frac{1}{4}$ -wavelength ground plane radials act as a mirror to RF energy, thus reflecting an image of the radiator. The radiator and its image work together in phase relationship to produce a colinear type action that lowers the angle of radiation to develop 4 dB gain in field strength intensity.

Unpacking

Unpack the CLR-2 and check the parts against the parts list. Refer to the drawings for help in becoming familiar with the parts.

NOTE: When unpacking your antenna, check the inside of all tubing for smaller tubing, etc. To conserve space, these smaller articles are sometimes put inside larger pieces.

M1 Section Assembly

Select the M1 section, base assembly (item 1) and the two radial plates (item 11). Slip the two radial plates over the top of the M1 tube section (item 3) and align the holes. Mount them as shown in Figure 3. Use $\frac{1}{4}$ " x 1" screws, nuts and lockwashers (item 27, 30, and 33).

NOTE: Insure that the plates set flush on top of the bracket. Also, note that the upper insulator (item 2) should fit through the center hole of the upper bracket and both radial plates. The $\frac{1}{4}$ " x 1" screws should bolt the radial plates, the upper bracket, and the plastic insulator securely together.

Select the $\frac{1}{4}$ " tubing clamp (item 14) and slip it over the top of the M1 section (item 3) as shown in Figure 4.

NOTE: To save time, assemble the compression clamps and their respective hardware prior to placing them on the elements. Refer to Figure 5 to identify the compression clamps and their hardware.

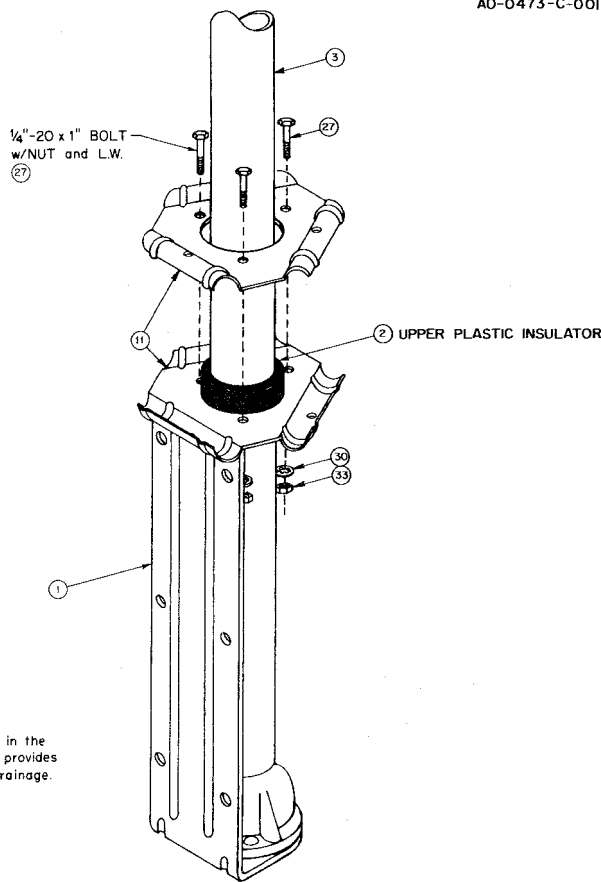

NOTE:
The extra hole in the
base assembly provides
proper water drainage.

Figure 3

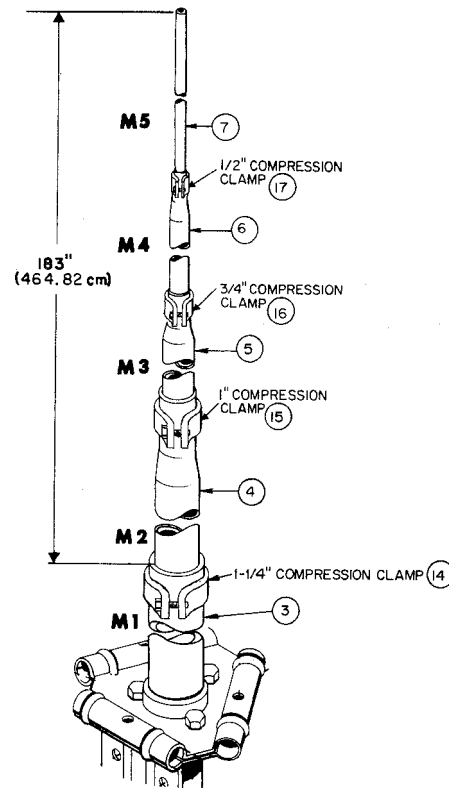

Figure 4

M2 Section Assembly

Select the $1\frac{1}{8}$ " x 47" M2 section (item 4) and slip the unswaged end into the top of the M1 tube (item 3), approximately $2\frac{1}{2}$ " or just so the black mark is covered.

Tighten the $1\frac{1}{4}$ " compression clamp (item 4) slightly, just enough to hold the M2 section in place. Select the 1" compression clamp and slip it over M2 section.

M3 Section Assembly

Select the $\frac{7}{8}$ " x 47" M3 section (item 5) and slip the unswaged end into the top of the M2 tube (item 4) as shown in Figure 4, approximately $2\frac{1}{2}$ ". Tighten the 1" compression clamp (item 15) just enough to hold the M3 section in place. Select the $\frac{3}{4}$ " compression clamp (item 16) and slip it over the top of the M3 section.

M4 Section Assembly

Select the $\frac{5}{8}$ " x 47" M4 section (item 6) and slip the unswaged end into the top of the M3 tube (item 5), approximately $2\frac{1}{2}$ ".

Tighten the $\frac{3}{4}$ " compression clamp (item 16) slightly, just enough to hold the M4 section of tubing.

Select a $\frac{1}{2}$ " compression clamp (item 17) and slip it over the top of the M4 section (item 6).

M5 Section Assembly

Select the $\frac{7}{16}$ " x 52" M5 section (item 7) and slip the open end into the top of the M4 section (item 6), approximately $2\frac{1}{2}$ ".

Tighten the $\frac{1}{2}$ " compression clamp just enough to hold the M5 section in place.

Measure from the top of the M1 section (item 1) to the top of the M5 section as shown in Figure 4. If this dimension is not correct, adjust the M5 section until it is correct, then tighten all compression clamps securely.

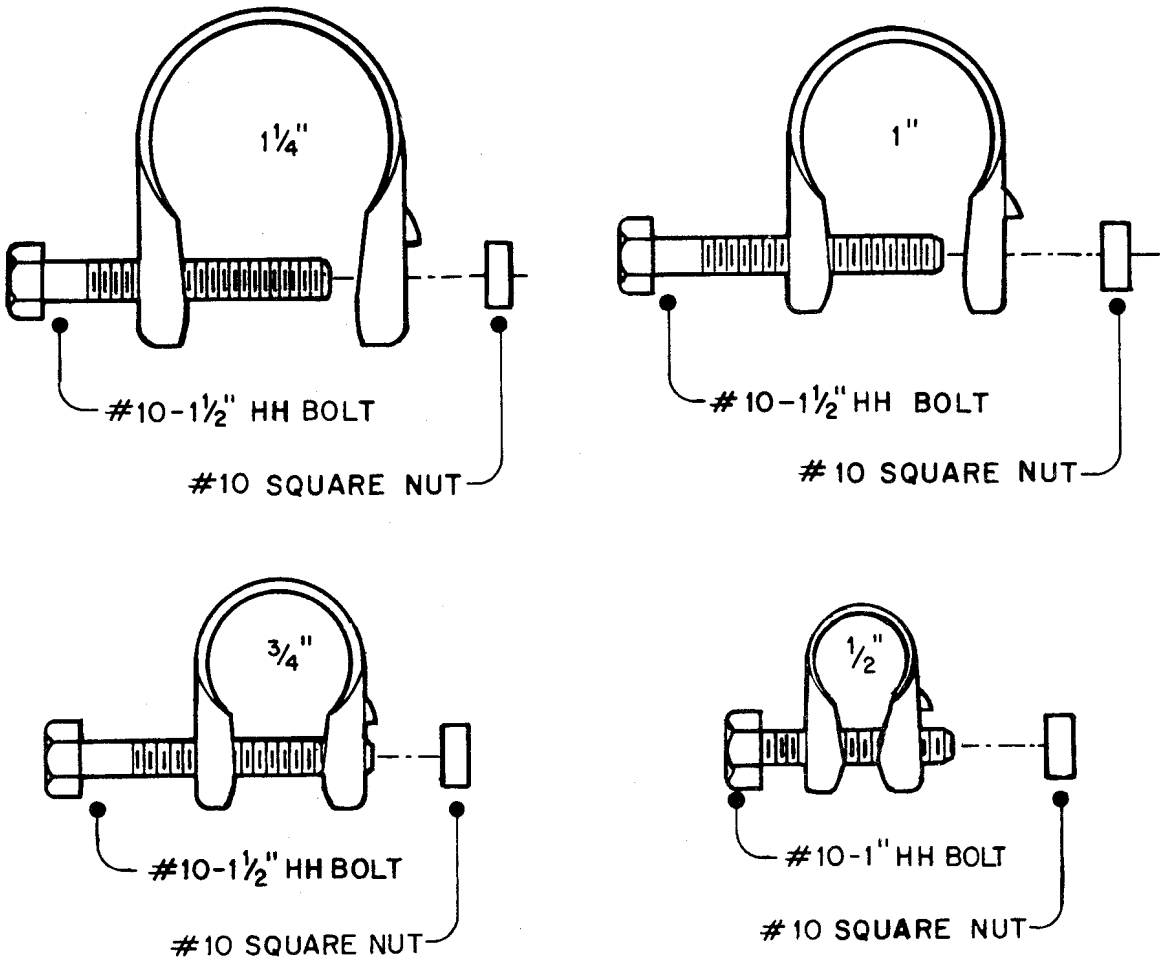

MA-0000-A-002

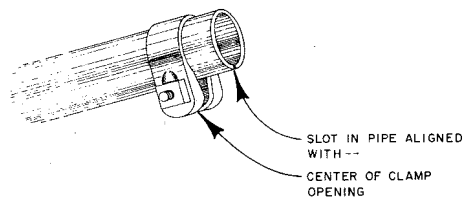

Figure 5

NOTE: Place the compression clamp on the edge of the tubing with the bolt even with the slot as shown in Figure 5.

Top Hat Assembly

Select the top hat radials (item 10) the 10-24 x 1" round head screw (item 25) and four #10 lockwashers (item 31). Place the following items on the #10 screw in the following order—lockwasher, a radial, lockwasher, radial, lockwasher, radial, lockwasher—and install into the top of the M5 section as shown in Figure 6. Tighten slightly.

Place three $\frac{1}{8}$ " caplugs (item 23) on the ends of the top hat radials.

Arrange the top hat radials so they are 120 degrees apart as shown in the figure, then tighten screw securely.

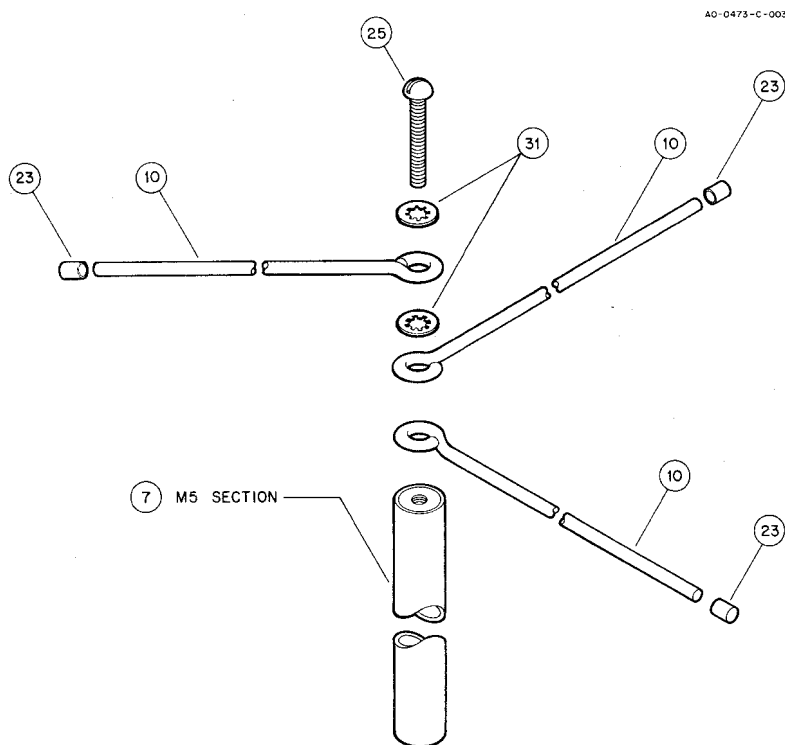

Figure 6

Assembly of Radials

Select the R1 and R2 sections (items 8 and 9) and the three remaining $\frac{1}{2}$ " compression clamps (item 17). Slip a compression clamp on the swaged end of the R1 radials (item 8). Slip on the end of the R2 tube (item 9) and measure each radial to see that you have 103 $\frac{1}{4}$ " as shown in Figure 7. Tighten the $\frac{1}{2}$ " compression clamp. Install a $\frac{7}{16}$ " caplug (item 24) on the end of the R2 sections.

NOTE: The sequence of the assembly from this point will be determined by how much manpower there is available and the mounting height of the antenna.

One-Man Mounting

If there is only one person available to mount the antenna, do not install the three radials into the radial brackets at this time.

Lift the base bracket with the assembled M1 through M5 sections to the top of your mast.

Mount to the mast using the $\frac{5}{16}$ " U-bolts in the pairs of holes near each end of the bracket. The middle pair of holes will not be used. Refer to Figure 7.

Bring the three radials to the top of the mast and attach them to the radial brackets. Align the holes and secure using the $\frac{1}{4}$ " x $1\frac{1}{4}$ " bolts, nuts and lockwashers (items 26, 33 and 30).

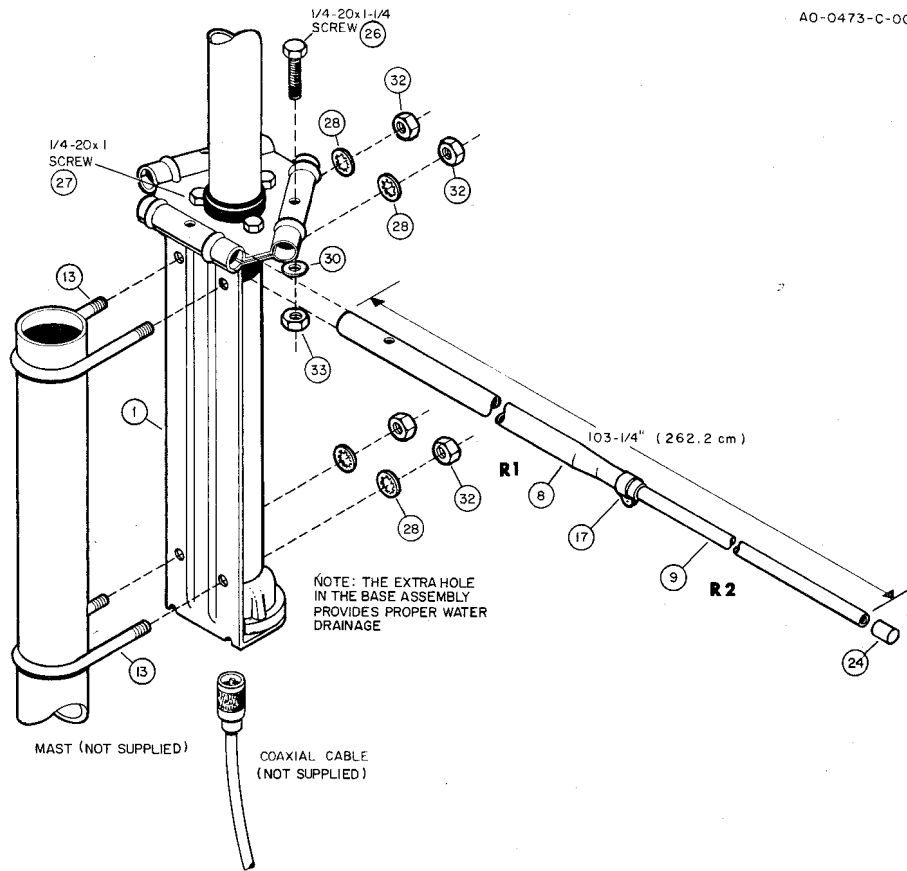

Figure 7

Two-Man Mounting

If there are two men to aid with the erection, you can go ahead and assemble the three radials on the radial brackets (item 11) and fasten securely with 1/4"-20 x 1 1/4" screw (item 26), 1/4"-20 nut (item 33), and 1/4" lockwasher (item 30). Then tighten securely.

While one man is climbing the ladder, tower, etc., the other man can hold the antenna so that none of the elements become bent or the top hat is damaged. This may happen if the radials are assembled and there is only one man to do the mounting. The antenna is too large for one man to mount when it is completely assembled before it is raised to the top of your mast.

Grounding

NOTE: Be sure that your antenna mast is properly grounded using an 8 ft. ground rod at the base of your mast.

If your mast is not properly grounded, you render the static arrestor useless making the antenna system susceptible to static build-up causing noise in your receiver.

When attaching the ground wire to the antenna, it is recommended that the wire be attached to one of the U-bolts on the base mount. Use #8 or larger copper or aluminum wire.

Attach the coaxial feedline to the SO-239 connector and weatherproof the connection using Pli-O-Bond, neoprene or some similar substance. Make certain all dirt and debris are cleaned from the SO-239 connector.

NOTE: If the input terminals of the SO-239 connector are checked with an ohmmeter, they will show a direct short. *This is normal!* The matching inductor places the entire antenna at DC ground while offering 52 ohms impedance rf energy giving a perfect match to RG-8/U coaxial cable.

Weatherproofing

To prolong the life of this product, in or around coastal areas, it is recommended that all hardware be encapsulated with a silicone rubber compound such as DOW-CORNING silastic rubber or G.E. silicone seal to prevent atmospheric deterioration.

Parts List

Item	Part No.	Description	Qty	Item	Part No.	Description	Qty
1	878803	M1, base assembly	1	16	380285	3/4" compression clamp	1
2	463056	Insulator, upper*	1	17	380284	1/2" compression clamp	4
3	190920	Tube, 1 1/4" x 47"	1	18	506445	Screw, #10 x 1 1/2" round head	2
4	170297	M2, tube, 1 1/8" x 47" marked	1	19	506450	Screw, #10 x 1 1/4", round head	1
5	170296	M3, tube, 7/8" x 47" marked	1	20		not applicable	
6	170295	M4, tube, 5/8" x 47" marked	1	21		not applicable	
7	875810	M5, tube, 7/16" x 52" w/insert	1	22	555362	nut, 10-24, square	7
8	173788	R1, tube, 5/8" x 53 1/4"	3	23	455624	caplug, 1/8"	3
9	175165	R2, tube, 7/16" x 52" marked	3	24	455644	caplug, 7/16"	3
10	173499	top hat radial	3	25	506455	screw, 10-24 x 1", round head	5
11	160008	radial plate	2	26	503451	screw, 1/4"-20 x 1 1/4", hex head	3
12	879238	Parts Pack, 473	1	27	506389	screw, 1/4"-20 x 1", hex head	3
13	543792	U-bolts	2	28	567075	lockwasher, 5/16", internal	5
14	380287	1 1/4" compression clamp	1	29		not applicable	
15	380286	380286		30	567110	lockwasher, 1/4", internal	10
15	380286	1" compression clamp	1	31	567125	lockwasher, #10, internal	7
				32	556945	nut, 5/16", hex	4
				33	556960	nut, 1/4"-20, hex	6

*Part numbers 463056 and 190920 are part of 878803 M1 base assembly and can be purchased separately.

Converting English Measurements to Metric

Use this scale to identify lengths of bolts, diameters of tubes, etc. The English (") and foot (') can be converted to centimeters in this way.

1 inch (1") = 2.54 cm
 1 foot (1') = 30.48 cm

Example:
 42" x 2.54 = 106.7 cm

