



TELEX COMMUNICATIONS, INC.
9600 ALDRICH AVE. SO. MINNEAPOLIS, MN 55420 U.S.A.

INSTRUCTION MANUAL

ORDER NO. 414

Big Gun II

PN 801323

General Description

This is a unique, super-sensitive, sharp beam, high gain, four element antenna with twin driven double loop elements. It offers both vertical and horizontal polarity. The new tiltable boom-to-mast clamp accepts 1 1/4" (3.2 cm) to 2 1/2" (6.4 cm) support masts. Either RG-58/u or RG-8/u may be used. For total feedline lengths in excess of 50 feet, RG-8/u cable is recommended.

Specifications

Electrical

Gain	14.6 dB
Front-to-back ratio	38.7 dB
Vertical-to-horizontal separation	18 dB
SWR at resonance	less than 1.5:1

Mechanical

Weight	39 lbs. (17.7 kg)
Overall length	20 ft. (609.6 cm)
Overall height	13'2" (401.3 cm)
Boom diameter	2" (5.1 cm)
Wind survival	90 mph (144.81 kmph)
Accommodates masts up to	2 1/2" (6.4 cm) O.D.
Wind load at 100 mph (161 kmph)	160 lbs. (72.5 kg)
Wind load at 80 mph (129 kmph)	104 lbs. (47.2 kg)
Wind area	5.7 sq. ft. (.53 m ²)

FOR OUR OVERSEAS CUSTOMERS: See the last page of this manual for additional information on identifying the English system of hardware and components supplied with this antenna.

Step-by-Step Assembly

() The antenna should be mounted in the clear and be no closer than 36 feet from any vertical and horizontal objects. The detrimental effects of surrounding objects are often underestimated. Powerlines and other metal objects will particularly affect the antenna's performance.

() Remove the antenna from the box and separate the parts by number listed in the parts list and shown on the parts. Care should be taken to insure proper part separation. A few extra minutes at this point may prevent a great deal of delay at a later stage of assembly.

() Refer to Figure 1 for the numbering detail of the antenna.

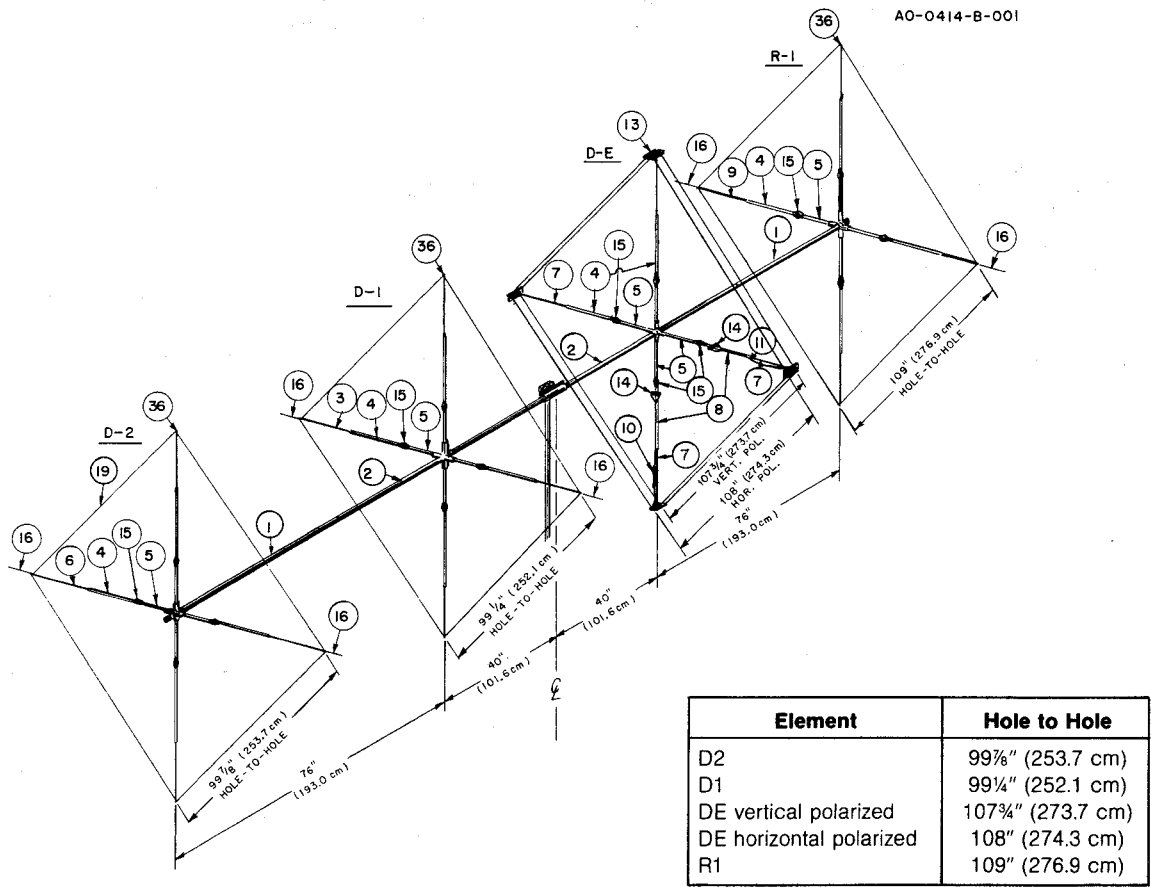

Element	Hole to Hole
D2	99 7/8" (253.7 cm)
D1	99 1/4" (252.1 cm)
DE vertical polarized	107 3/4" (273.7 cm)
DE horizontal polarized	108" (274.3 cm)
R1	109" (276.9 cm)

Figure 1

Director No. 2

() Start your assembly with the number 2 director spreader arms. Refer to Figure 2. Do not attach to the boom-to-spreader brackets at this time. Lay all four of these spreader arms in one group.

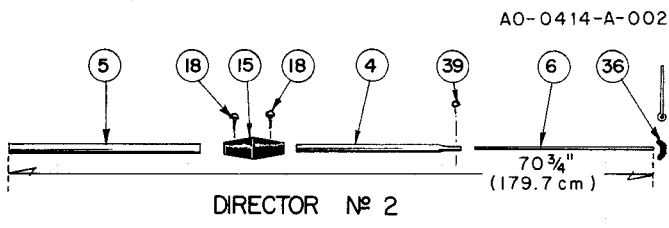

Figure 2

Director No. 1

() Next refer to Figure 3 for assembly of the No. 1 director spreader arms. Lay these four assembled spreader arms together.

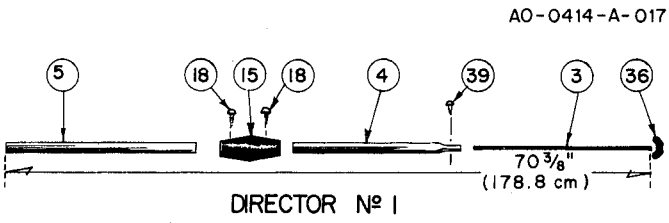
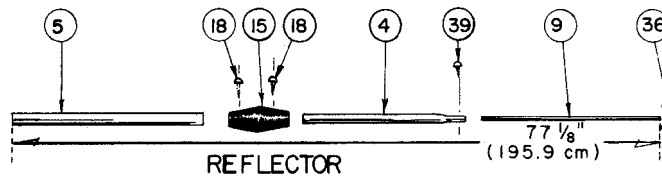

Figure 3

Reflector (REF)

() Referring to Figure 4, assemble the reflector spreader arms and lay these in a group by themselves.



AO-0414-A-018

Figure 4

Driven Element (DE)

() The last set of spreader arms to be assembled is the driven element. By referring to Figure 5, assemble the elements in a similar manner as you did the two directors and the reflector.

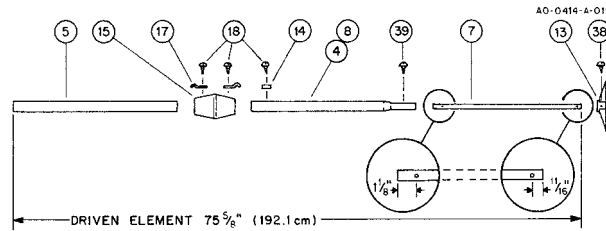

AO-0414-A-019

Figure 5

Spreader-to-Boom Brackets Attachment

() Refer to Figure 6 for boom numbering and bracket assembly detail. Various methods may be used to assemble the spreader arms on the boom. However, the easiest method seems to be the attachment of a set of four brackets on each section of the boom before the boom sections are bolted together.

() With a marking pencil mark a line $39\frac{7}{8}$ " (101.3 cm) from the unswaged end of item 2 (the 2" (5.1 cm), swaged boom section). This will be the location of the driven element brackets. Mark on this boom section DE. Take the remaining item 2 and again mark $39\frac{7}{8}$ " (101.3 cm) from the unswaged end and place a mark. This will be the bracket location for the Director No. 1 spreader arms. (Mark on this boom section D1).

() With a marking pencil, mark a line $4\frac{3}{8}$ " (11.1 cm) from the undrilled end of the boom tube No. 1. This will be the location of the reflector spreader arm bracket. Mark on this boom section R1.

() Repeat this on the last remaining 2" (5.1 cm) boom section for the location of the Director No. 2 brackets. Mark on this boom section D2.

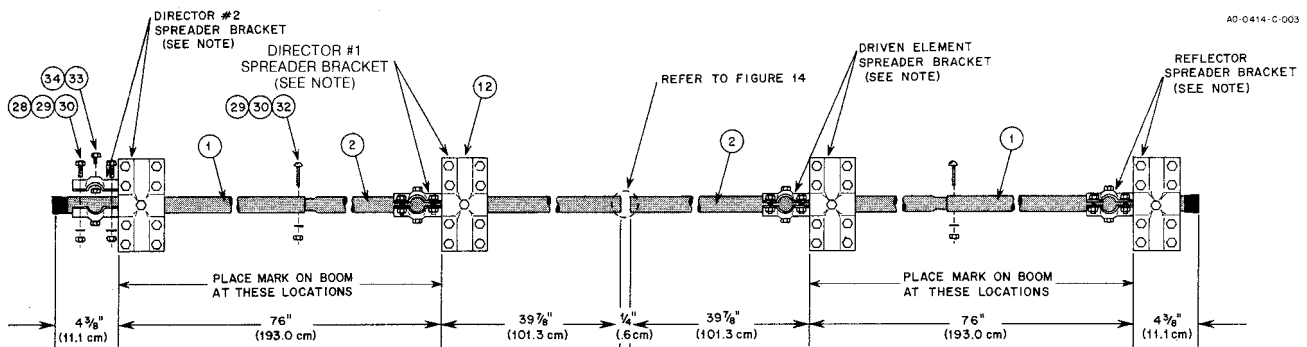

AO-0414-C-003

Figure 6

() Use two of item 12 and refer to Figure 6, loosely assemble all the brackets using the $\frac{1}{4}$ " x $\frac{3}{4}$ " bolts and associated lockwashers and nuts.

() Before placing each pair of brackets on their respective boom sections, make sure the $\frac{1}{4}$ " square nut is placed under each bracket (refer to Figure 7). This is used to accept the $\frac{1}{4}$ " anchor screw which is assembled into the bracket after each pair is attached and located on the boom section.

NOTE: Each pair of brackets must be located on each side of the marks previously placed on the boom. Before tightening the hardware in the next four steps make sure the brackets will line up, as in Figure 6, when the booms are assembled.

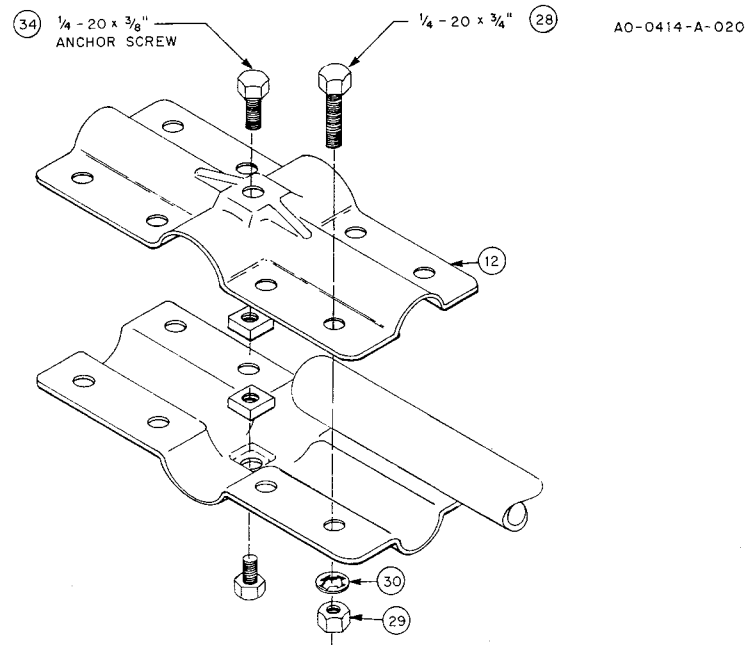

Figure 7

() After a set of four brackets have been loosely placed on each boom section, refer to the group of Director No. 2 spreader arms and insert the large end of each arm into the bracket located on the boom section previously marked D2. Tighten the $\frac{1}{4}$ " hardware just enough to hold the arms in the brackets. **Do not** tighten the anchor screws at this time.

() Insert the large end of the D1 spreader arms into the brackets assembled on the boom section marked D1. Tighten the hardware just enough to hold the arms in the brackets. **Do not** tighten the anchor screws at this time.

() Assemble the driven element spreader arms into the brackets assembled on the boom section marked DE. Tighten the hardware just enough to hold the arms in the brackets. **Do not** tighten the anchor screws at this time.

() Insert the last group of four spreader arms into the brackets assembled on the boom section marked R1. Tighten the hardware just enough to hold the arms in the brackets. **Do not** tighten the anchor screws at this time.

You should now have four separate sections of boom with a set of spreader arms assembled on each section.

Element Wire Hook-up

Refer to Figure 1 and Figure 11 for wire attachment, spacing and dimensions for the driven element.

NOTE: Extreme care should be taken to insure the element wire does not kink, if this occurs and the wire is allowed to be pulled tight, damage to the wire can result.

() It is easier to measure and cut the wire before installation. For the horizontally polarized loop, prepare a wire and mark as shown in Figure 8.

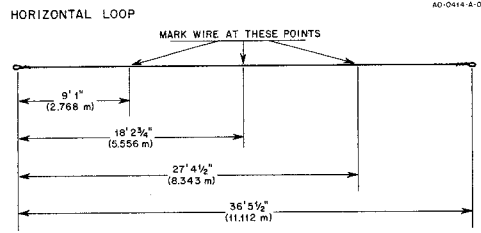

Figure 8

() For the vertically polarized loop, prepare a wire and mark as shown in Figure 9.

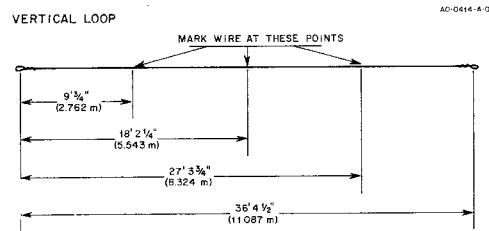

Figure 9

() Refer to Figure 10 to install the wires on the driven element spreaders. Connect them as shown in the electrical diagram. The marks on the wires should be centered on the driven element insulators (item 13).

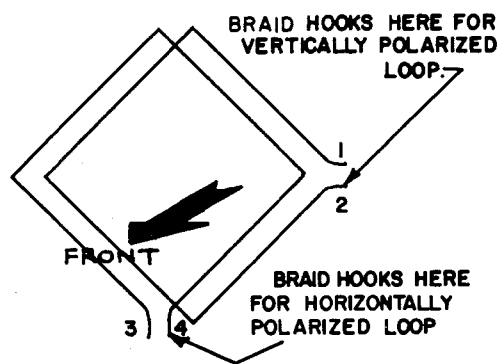

Figure 10

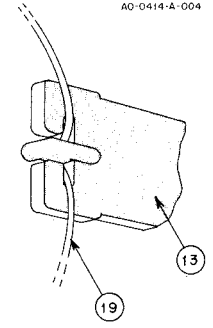
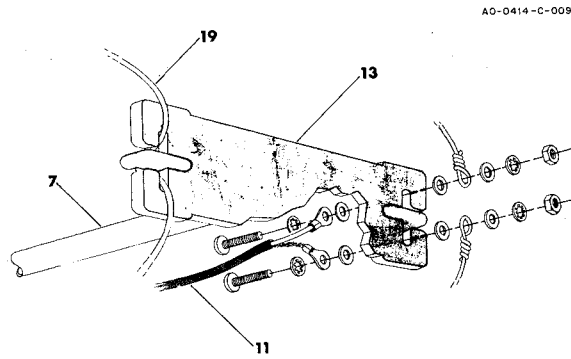
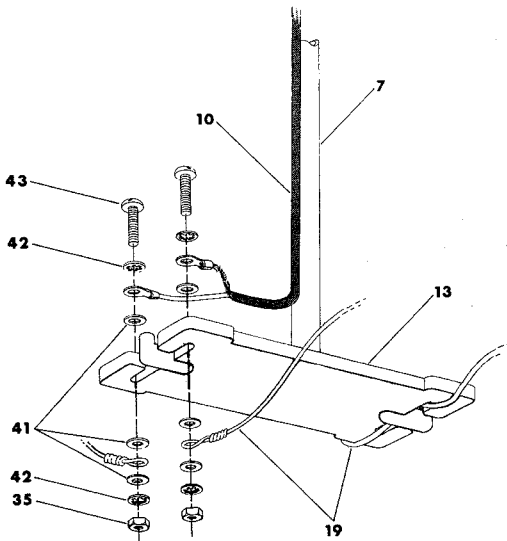

Figure 11

() The wires should be threaded through the insulator (13) as shown.

() The parasitic element wires are measured and marked as shown in Figure 12.

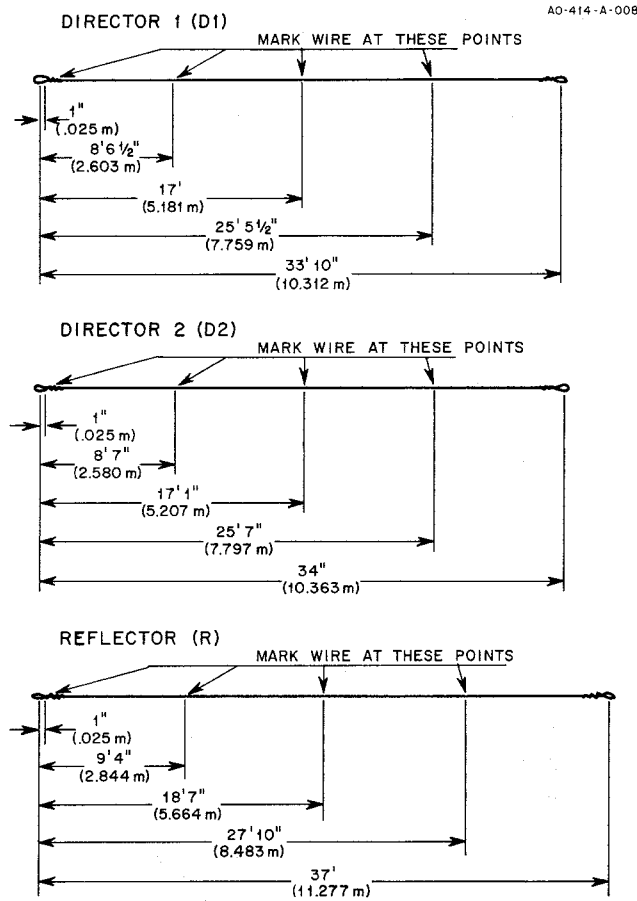
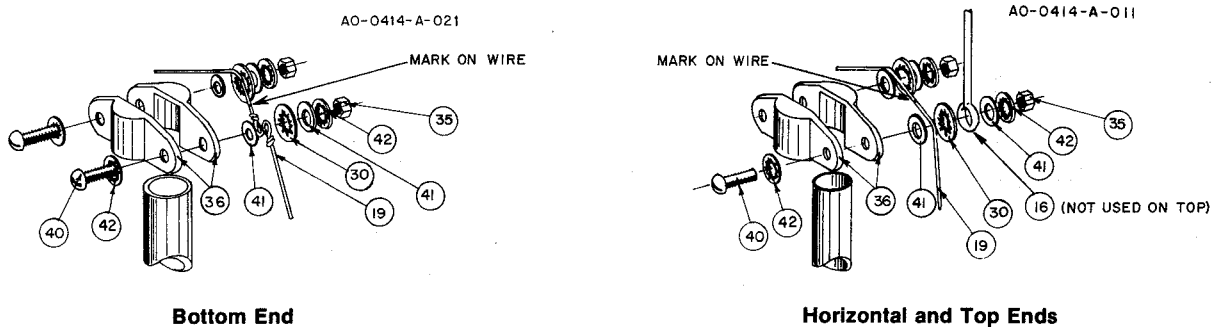

Figure 12

() Care should be taken to insure an accurate measurement of each element length. This is extremely critical for efficient operation of the antenna.

() Refer to Figure 12 and Figure 13 for measurement lengths and attachment of element wire for reflector, director No. 1, and director No. 2. The marks on the wires should be centered on the horizontal insulators (item 36). The distance between the insulators should be approximately those shown in Figure 1.



() After all elements are attached to the spreader arms, refer to Figure 6 and attach each boom section together using the hardware shown. Attachment of the boom-to-mast bracket may be made at this time. Refer to Figure 14.

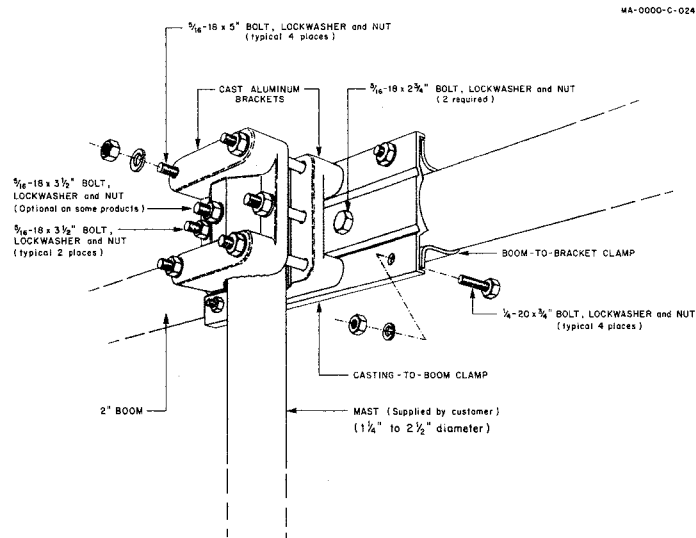

Figure 14

() Check all dimensions between brackets by referring to Figure 6. Adjust if necessary. Align all spreader arm assemblies as shown in Figure 1.

() Install the 1/4" anchor screw in the brackets as shown in Figure 7 and tighten securely. Also tighten the hardware on the brackets securely.

() Install all 1/8" x 6" wire stubs (item 16) on the ends of the horizontal parasitic elements as shown in Figures 1 and 13.

() To adjust loose elements, loosen the brackets of the appropriate spreader arms one at a time. Move each spreader arm out in 1/4" (about 5 mm) increments and retighten all screws securely. Repeat this process until the element wires are tensioned. If the wires are too tight, remove the screw (item 39) in the spreader tube number 4 and let the outer tube telescope inward until the wire is tight.

() Attach the RG-58/u (item 11) and RG-59/u (item 10) harnesses and the coax as shown in Figures 11 and 15.

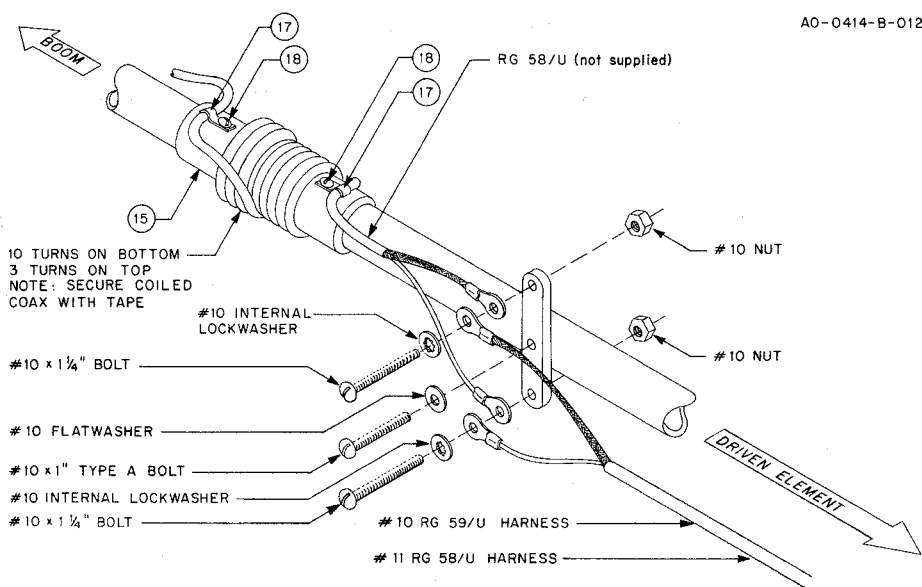

Figure 15

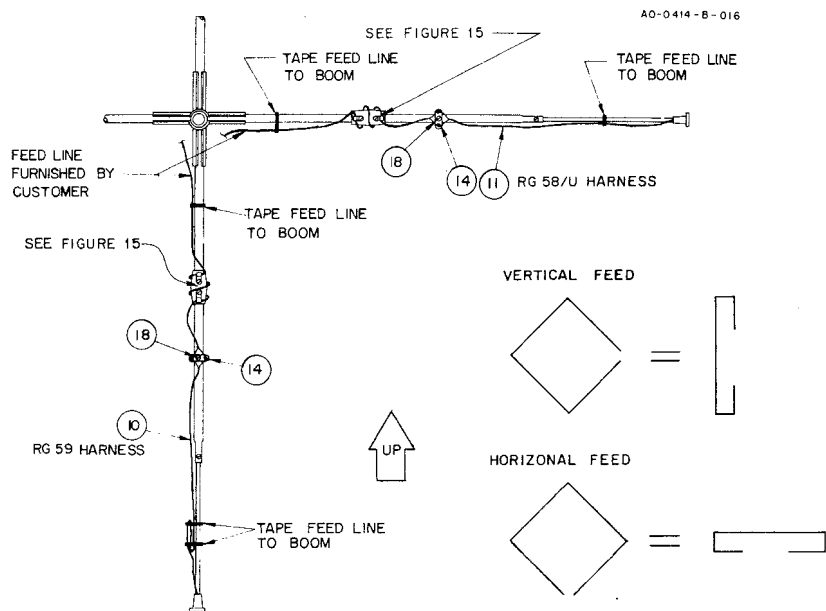

Figure 16

() Attach your coax (not supplied as part of this product) to the insulator shown, making sure it is wrapped around the spreader insulator as shown in Figure 16. The coil must be made of RG-58/u (unless stacking two antennas) to insure proper operation of the antenna. If RG-8/u cable is used to feed the antenna, it must be spliced to RG-58/u to wind the coil.

Mounting and Installation

() This completes the assembly of your "Big Gun" selectable polarization antenna.

() The antenna is now ready to be installed on the mast. The boom-to-mast is designed for 1 1/4" (3.2 cm) to 2 1/2" (6.4 cm) outside mast material.

NOTE: To prolong the life of this product in or around coastal areas, it is recommended that all hardware be encapsulated with a silicone rubber compound such as DOW-CORNING silastic rubber or GE silicone seal to prevent atmospheric deterioration.

If the antenna is mounted on a tower, best results will be obtained if the tip of the lower vertical element is above the tip of the tower.

() Tape the coaxial feedline to the support mast, run them around the rotor, then down the support structure. A sufficient loop should be provided around the rotor for rotation of the antenna without undue strain on the coaxial feedlines.

() Attach the coaxial feedlines to the polarization switch using PL-259 connectors. The feedlines from the vertical element should be connected to the vertical input and the feedline from the horizontal element connect to the horizontal input. See Figure 17.

AO-0414-A-013

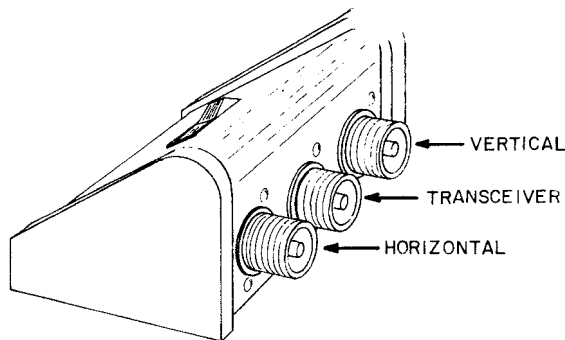

Figure 17
Polarization Switch

() Any convenient length of coaxial cable may be used between the polarization switch and the transceiver.

The antenna must operate independent of other antenna systems. You cannot extend the support mast and erect an omnidirectional ground plane. If this is done, it will deteriorate the performance of both the ground plane and the quad. The most detrimental effect would be to the quad.

The minimum mounting height for reasonable performance from directional Citizens Band antennas is 36 feet to the bottom tips of the elements. Additional height, where legal, will lower the angle of radiation and improve the performance of the system.

If the tower or mast support utilizes guy wires, they should be broken up with egg insulators every three feet for the first forty feet from the top. The first insulator should be as close to the tower as possible. The antenna is capable of shock exciting (inducing voltages) the guy wires and existing structures nearby up to a distance of 75 feet (about 25 m).

Grounding of the antenna is extremely important with regard to elimination of TVI, precipitation noise and electro-static charges due to rain and snow. If the support structure is house mounted, be sure to run a ground wire from the mast or support structure to an eight foot ground rod.

Quad Stacking

NOTE: Two Big Guns can be stacked for even better performance. This will provide an increase in gain of 3 dB effectively doubling power output. The fittings necessary are available in nearly every locality.

() Build four RG-59/u (72 ohm) phasing lines as in Figure 19.

() Make cross-support boom 21' (640.1 cm) long and 2½" (6.4 cm) maximum diameter. Make arrangements to attach it to the mast.

() Finish the assembly of both antennas.

AO-0414-A-014

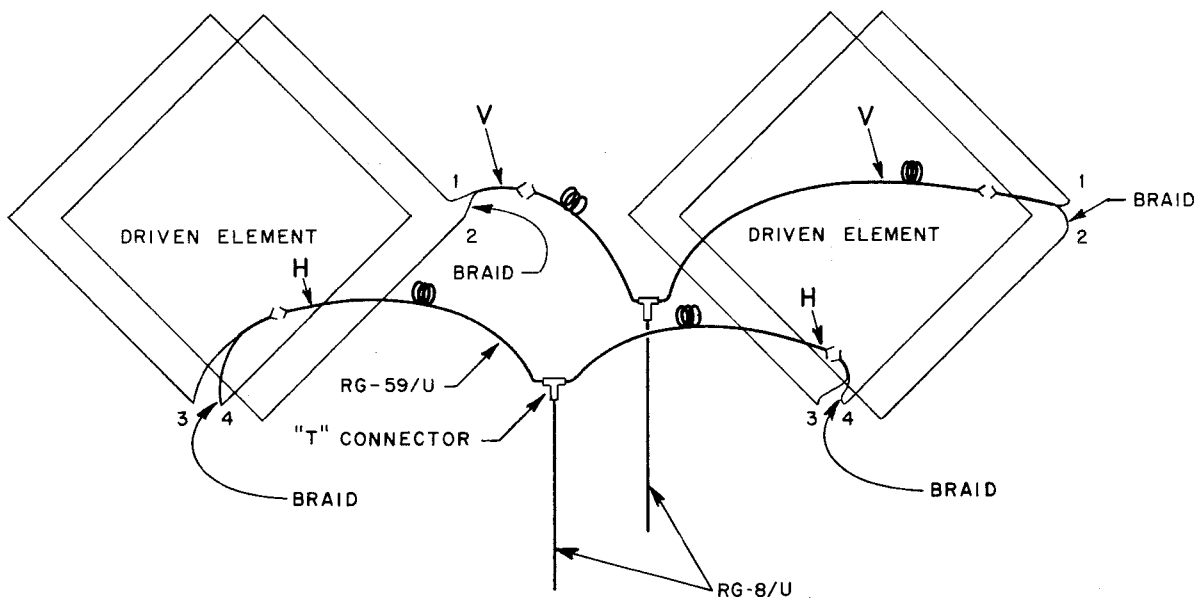

Figure 18

NOTE: Be sure the feedlines and ¼-wave matching transformers are similarly placed on the booms of both antennas so they will be properly connected in phase.

() Mount the antennas on the cross arm.

() Attach phasing lines to antenna feed points as illustrated. They must be wound on the insulator exactly the same as the RG-58/u is for a single antenna. Check antenna feed system carefully to be certain it is as illustrated in the manual. This will insure proper phasing and operation of your stacked "Big Guns".

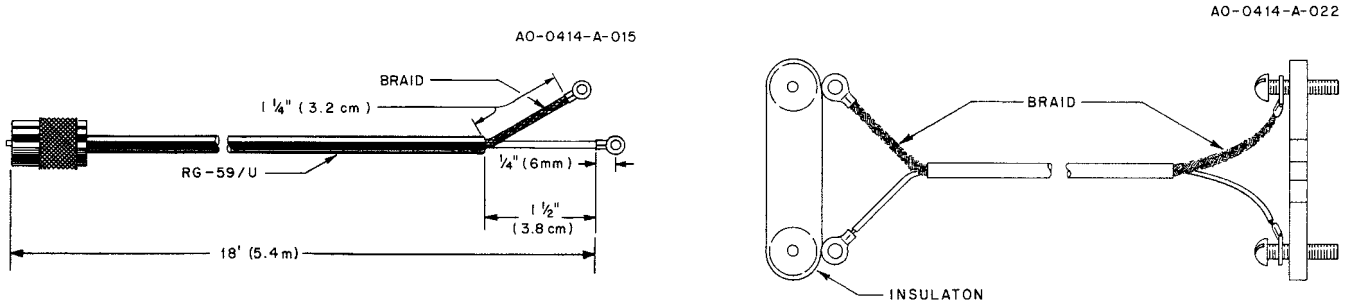

Figure 19

() When attaching the coax to the stacked antennas, the braid should be connected to the right side of the right horizontal spreader. See Figure 11.

() Join the horizontal phasing lines in a "T" connection.

() Attach and join the vertical phasing lines as was done with the horizontal lines above.

() Attach RG-8/u feedlines now or later.

() Raise the completed assembly into position and attach to mast.

() Secure the phasing lines and feedlines to the mast. Leave slack if antennas will be rotated.

Conversion of English System to Metric System

Use this scale to identify lengths of bolts, diameters of tubes, etc. Further, the English inch and foot can be converted to centimeters thus:

$$1 \text{ inch (1")} = 2.54 \text{ cm}$$

$$1 \text{ foot (1')} = 30.48 \text{ cm}$$

Example:

$$42" \times 2.54 = 106.7 \text{ cm}$$



Parts List

Item	Part No.	Description	Qty	Item	Part No.	Description	Qty
1	175439	2" boom tube	2	23	501543	screw, 5/16"-18 x 5", hex head	4
2	175438	2" boom tube, swaged inner	2	24	556945	nut, 5/16"-18, hex	9
3	170528	3/8" x 36" D1 tube	4	25	567085	flatwasher, 5/16"	9
4	170532	3/8" x 20" swaged tube	14	26	501541	screw, 5/16"-18 x 3 1/2", hex head	3
5	170531	7/8" x 17" tube	16	27	506741	screw, 5/16"-18 x 2 3/4", hex cap	2
6	170530	3/8" x 36 1/2" D2	4	28	506325	screw, 1/4"-20 x 3/4", hex head	68
7	170368	3/8" x 40 1/2" DE	4	29	556960	nut, 1/4"-20 hex	72
8	170524	7/8" x 20" drilled DE	2	30	567110	lockwasher, 1/4" internal	96
9	170529	3/8" x 43" RE	4	31	567080	lockwasher, 5/16" split	9
10	870045	72" RG-59/u	1	32	506290	screw, 1/4" x 2 1/2" round head	2
11	870047	feedline #11	1	33	558685	nut, 1/4" square	16
12	163764	3/8" to 2" brackets	16	34	505540	screw, 1/4"-20 x 3/8", hex head	16
13	460001	driven element insulator	4	35	556970	nut, #10-24, hex	66
14	465410	insulator	4	36	463242	"Toreador" insulator	24
15	460002	spreader insulator	16	37	455625	2" end cap	2
16	170522	horizontal stubs	6	38	513023	screw, #8 x 3/8" type A, hex head	4
17	163266	clip	4	39	519386	screw, #8 x 3/8" type A, hex head	16
18	510716	#10 x 1" type A	34	40	506450	screw, #10-24 x 1 1/4", round head	28
19	690001	alumaweld element wire	190 ft.	41	567130	flatwasher, #10	68
20	102734	mast casting	2	42	567125	lockwasher, #10 internal	61
21	172735	boom-to-casting plate	1	43	506460	screw, #10-24 x 3/4", round head	4
22	172732	boom-to-mast extrusion	1	44	870634	two-way switch	1