

KLV 2000 L Command board

Version 1.00

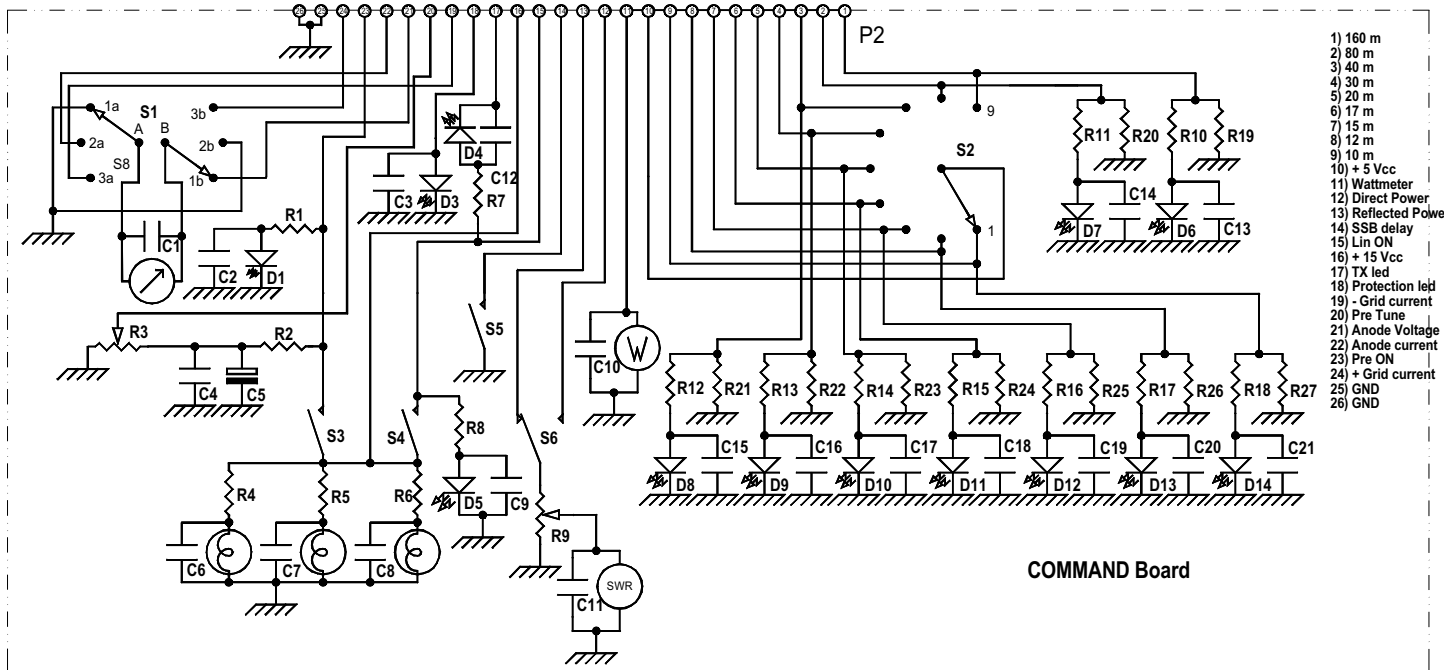
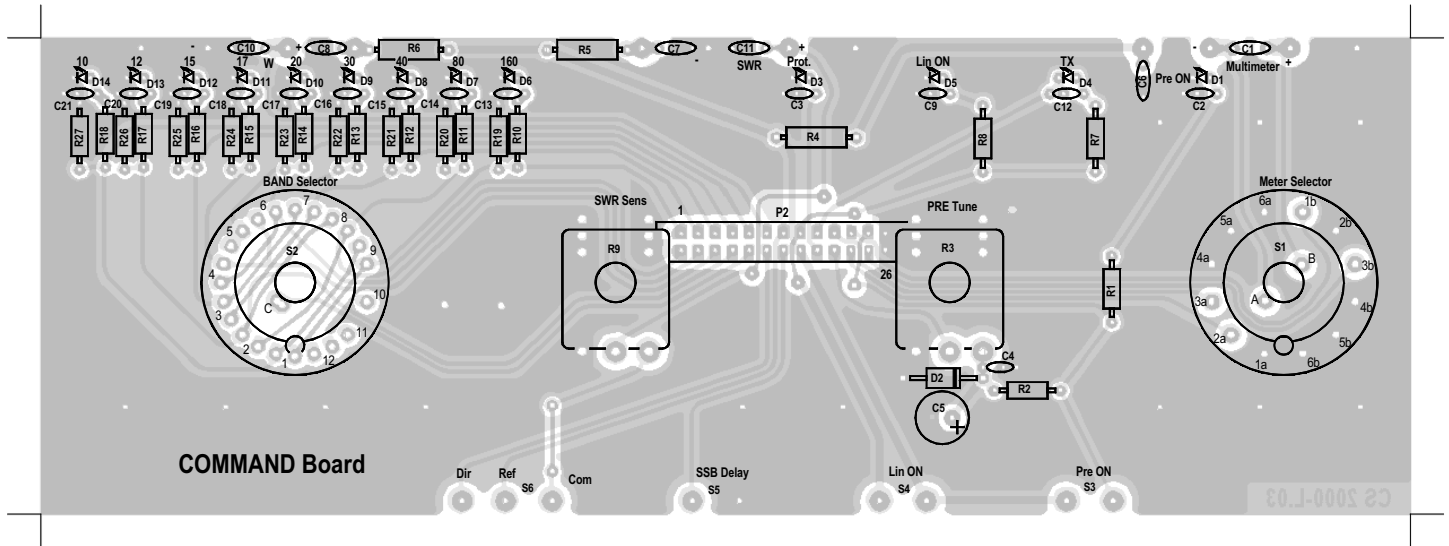

LIST OF Components

C 1	=	100 nF	50 V	R 27	=	1,0 K Ω	$\frac{1}{4}$ W
C 2	=	10 nF	50 V	D 1	=	High brightness Yellow LED	
C 3	=	10 nF	50 V	D 3	=	High brightness Red LED	
C 4	=	10 nF	50 V	D 4	=	High brightness Red LED	
C 5	=	470 μ F	16 V	D 5	=	High brightness Green LED	
C 6	=	100 nF	50 V	D 6	=	High brightness Green LED	
C 7	=	100 nF	50 V	D 7	=	High brightness Green LED	
C 8	=	100 nF	50 V	D 8	=	High brightness Green LED	
C 9	=	10 nF	50 V	D 9	=	High brightness Green LED	
C 10	=	100 nF	50 V	D 10	=	High brightness Green LED	
C 11	=	100 nF	50 V	D 11	=	High brightness Green LED	
C 12	=	10 nF	50 V	D 12	=	High brightness Green LED	
C 13	=	10 nF	50 V	D 13	=	High brightness Green LED	
C 14	=	10 nF	50 V	D 14	=	High brightness Green LED	
C 15	=	10 nF	50 V	S 1	=	Meter selector switch (COM 190900010)	
C 16	=	10 nF	50 V	S 2	=	Band selector switch (COM 190800010)	
C 17	=	10 nF	50 V				
C 18	=	10 nF	50 V				
C 19	=	10 nF	50 V				
C 20	=	10 nF	50 V				
C 21	=	10 nF	50 V				
R 1	=	1,2 K Ω	$\frac{1}{4}$ W				
R 2	=	10 Ω	$\frac{1}{4}$ W				
R 3	=	Potentiometer 4,7 K Ω (POT 1811004/7)					
R 4	=	47 Ω	$\frac{1}{2}$ W				
R 5	=	47 Ω	$\frac{1}{2}$ W				
R 6	=	47 Ω	$\frac{1}{2}$ W				
R 7	=	1,2 K Ω	$\frac{1}{4}$ W				
R 8	=	1,2 K Ω	$\frac{1}{4}$ W				
R 9	=	Potentiometer 4,7 K Ω (POT 1811004/7)					
R 10	=	270 Ω	$\frac{1}{4}$ W				
R 11	=	270 Ω	$\frac{1}{4}$ W				
R 12	=	270 Ω	$\frac{1}{4}$ W				
R 13	=	270 Ω	$\frac{1}{4}$ W				
R 14	=	270 Ω	$\frac{1}{4}$ W				
R 15	=	270 Ω	$\frac{1}{4}$ W				
R 16	=	270 Ω	$\frac{1}{4}$ W				
R 17	=	270 Ω	$\frac{1}{4}$ W				
R 18	=	270 Ω	$\frac{1}{4}$ W				
R 19	=	1,0 K Ω	$\frac{1}{4}$ W				
R 20	=	1,0 K Ω	$\frac{1}{4}$ W				
R 21	=	1,0 K Ω	$\frac{1}{4}$ W				
R 22	=	1,0 K Ω	$\frac{1}{4}$ W				
R 23	=	1,0 K Ω	$\frac{1}{4}$ W				
R 24	=	1,0 K Ω	$\frac{1}{4}$ W				
R 25	=	1,0 K Ω	$\frac{1}{4}$ W				
R 26	=	1,0 K Ω	$\frac{1}{4}$ W				