

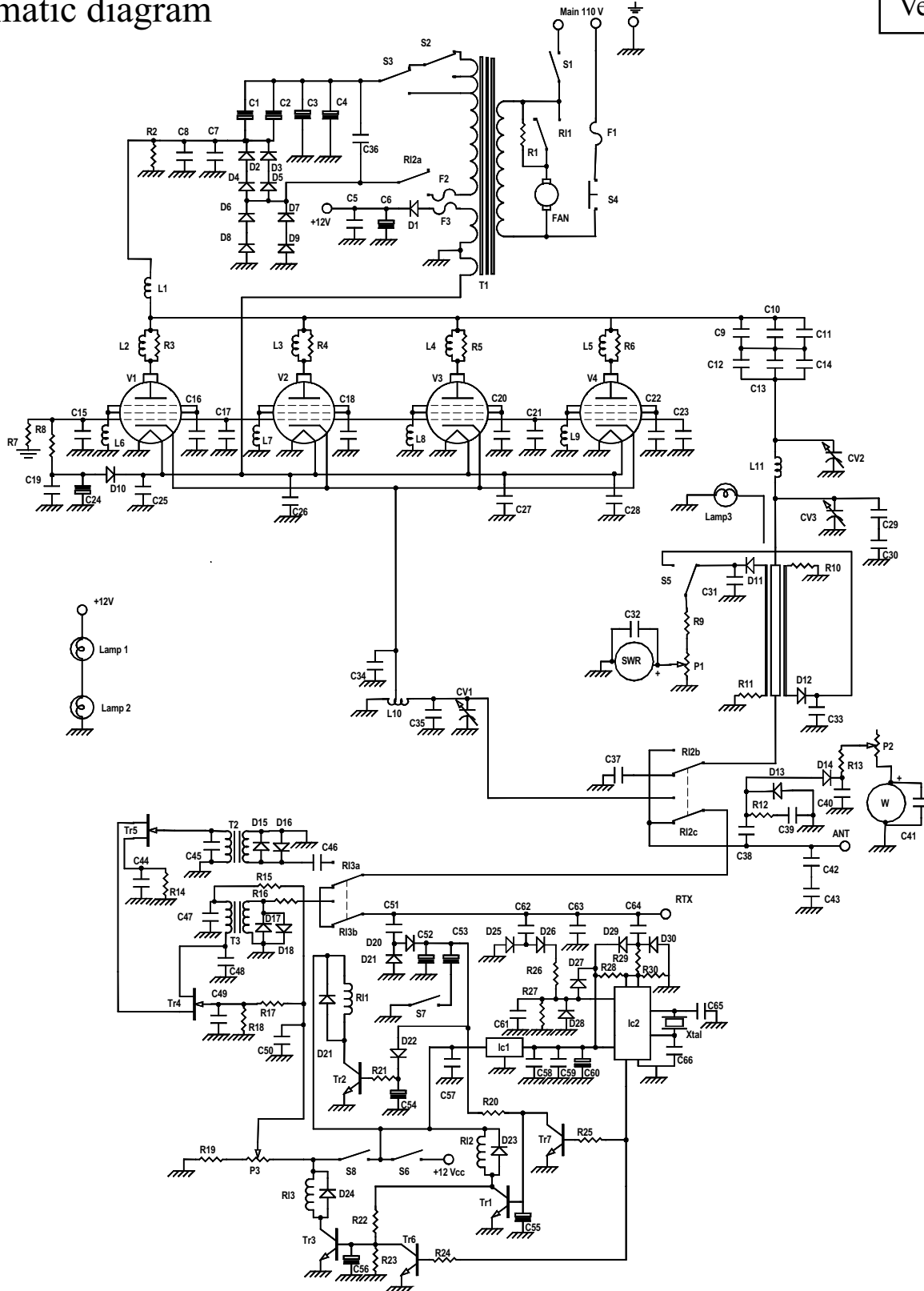

Mod. KLV 1000 P linear amplifier

Schematic diagram

Version 2.10



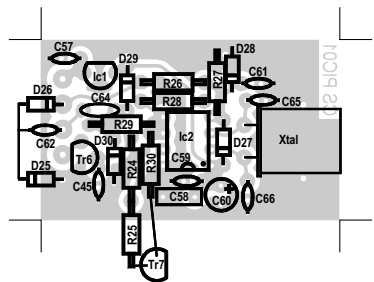
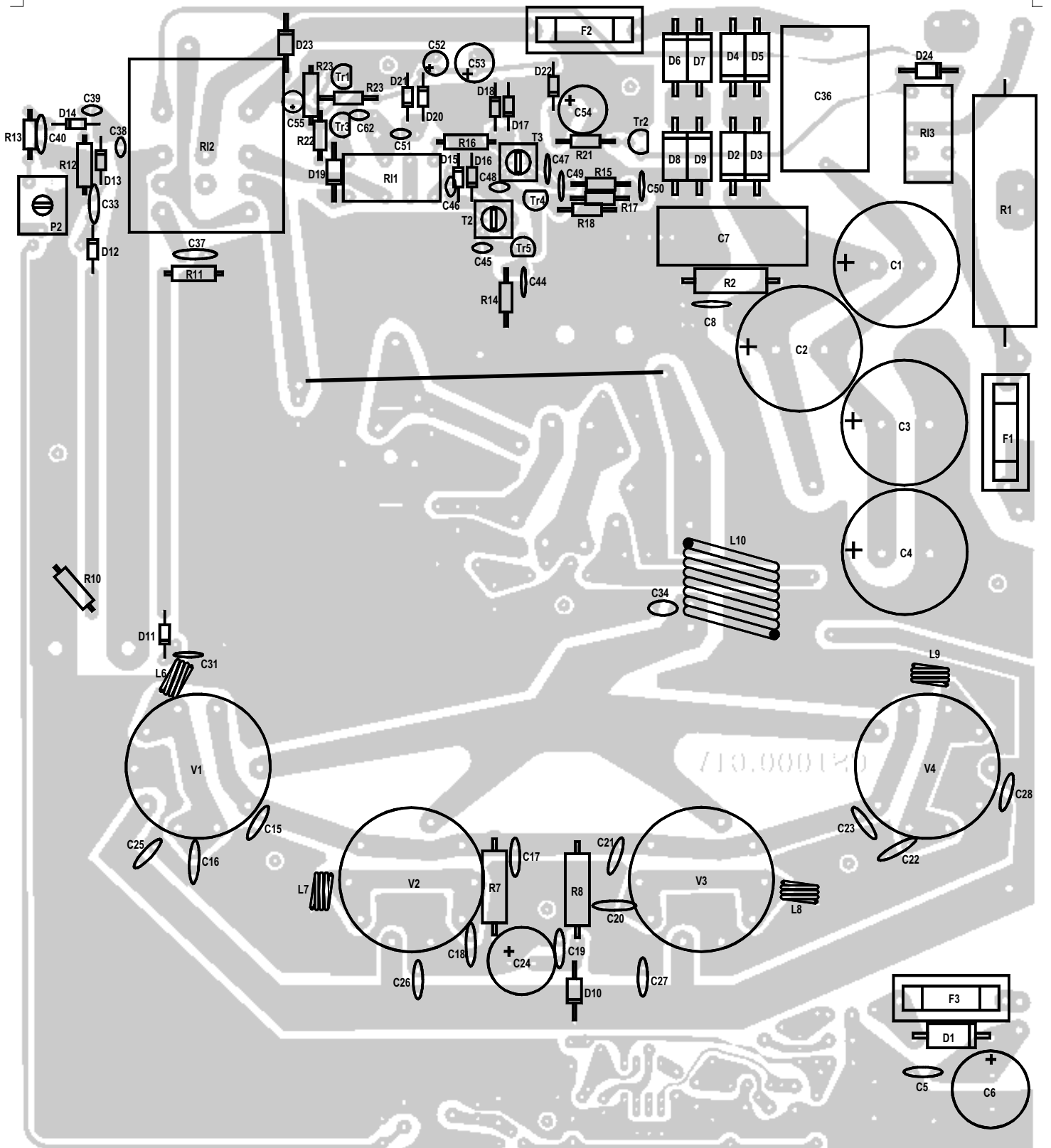

List of components

C ₁	= 100 µF	450 V		C ₄₉	= 10 nF	50V	
C ₂	= 100 µF	450 V		C ₅₀	= 10 nF	50V	
C ₃	= 100 µF	450 V		C ₅₁	= 2,2 pF	50 V	N750
C ₄	= 100 µF	450 V		C ₅₂	= 10 µF	16 V	
C ₅	= 100 nF	50V		C ₅₃	= 47 µF	16 V	
C ₆	= 2200 µF	16 V		C ₅₄	= 220 µF	16 V	
C ₇	= 22 nF	1000V		C ₅₅	=		
C ₈	= 2,2 nF	1000 V		C ₅₆	= 10 µF	16 V	
C ₉	= 2,2 nF	1500 V		C ₅₇	= 10 nF	50V	
C ₁₀	= 2,2 nF	1500 V		C ₅₈	= 100 nF	63V	polyester
C ₁₁	= 2,2 nF	1500 V		C ₅₉	= 10 nF	50V	
C ₁₂	= 2,2 nF	1500 V		C ₆₀	= 10 µF	16 V	
C ₁₃	= 2,2 nF	1500 V		C ₆₁	= 10 nF	50V	
C ₁₄	= 2,2 nF	1500 V		C ₆₂	= 3,3 pF	50 V	N750
C ₁₅	= 100 nF	50V		C ₆₃	= 27 pF	50 V	N750
C ₁₆	= 150 pF	500 V	N750	C ₆₄	= 2,2 pF	50 V	N750
C ₁₇	= 100 nF	50V		C ₆₅	= 27 pF	50 V	NP0
C ₁₈	= 150 pF	500 V	N750	C ₆₆	= 27 pF	50 V	NP0
C ₁₉	= 100 nF	50V		Cv ₁	= Variable condensator	50 pF	
C ₂₀	= 150 pF	500 V	N750	Cv ₂	= Variable condensator	50 pF	
C ₂₁	= 100 nF	50V		Cv ₃	= Variable condensator	350 pF	
C ₂₂	= 150 pF	500 V	N750	R ₁	= 820 Ω	17W	
C ₂₃	= 100 nF	50V		R ₂	= 470 KΩ	2W	
C ₂₄	= 470 µF	50 V		R ₃	= 47 Ω	5W	
C ₂₅	= 100 nF	50 V		R ₄	= 47 Ω	5W	
C ₂₆	= 100 nF	50 V		R ₅	= 47 Ω	5W	
C ₂₇	= 100 nF	50 V		R ₆	= 47 Ω	5W	
C ₂₈	= 100 nF	50 V		R ₇	= 1,0 KΩ	2W	
C ₂₉	= 270 pF	500 V	N750	R ₈	= 100 Ω	2W	
C ₃₀	= 270 pF	500 V	N750	R ₉	= 47 KΩ	¼W	
C ₃₁	= 100 nF	50 V		R ₁₀	= 100 Ω	½W	
C ₃₂	= 100 nF	50 V		R ₁₁	= 100 Ω	½W	
C ₃₃	= 100 nF	50 V		R ₁₂	= 27 Ω	½W	
C ₃₄	= 82 pF	500 V	N750	R ₁₃	= 47 KΩ	¼W	
C ₃₅	= 47 pF	500 V	N750	R ₁₄	= 180 Ω	¼W	
C ₃₆	= 470 nF	630 V~		R ₁₅	= 470 Ω	¼W	
C ₃₇	= 470 pF	50 V	N750	R ₁₆	= 15 Ω	2W	
C ₃₈	= 2,2 pF	50 V	N750	R ₁₇	= 56 KΩ	¼W	
C ₃₉	= 33 pF	50 V	N750	R ₁₈	= 22 KΩ	¼W	
C ₄₀	= 100 nF	50 V		R ₁₉	= 4,7 KΩ	¼W	
C ₄₁	= 100 nF	50 V		R ₂₀	= 2,2 KΩ	¼W	
C ₄₂	= 68 pF	500 V	N750	R ₂₁	= 2,2 KΩ	¼W	
C ₄₃	= 68 pF	500 V	N750	R ₂₂	= 12 KΩ	¼W	
C ₄₄	= 10 nF	50V		R ₂₃	= 680 Ω	¼W	
C ₄₅	= 27 pF	50 V	N750	R ₂₄	= 1,0 KΩ	¼W	
C ₄₆	= 10 nF	50V		R ₂₅	= 1,0 KΩ	¼W	
C ₄₇	= 10 nF	50V		R ₂₆	= 56 KΩ	¼W	
C ₄₈	= 33 pF	50 V	N750	R ₂₇	= 1,0 MΩ	¼W	
				R ₂₈	= 10 KΩ	¼W	

$R_{29} = 100 \Omega \quad \frac{1}{4}W$
 $R_{30} = 10 K\Omega \quad \frac{1}{4}W$
 $P_1 = \text{Potenziometro } 4,7 K\Omega$
 $P_3 = \text{Potenziometro } 4,7 K\Omega$
 $P_2 = \text{Trimmer } 220 K\Omega$
 $D_1 = 1N5400$
 $D_2 = D_3 = D_4 = D_5 = BY 255$
 $D_6 = D_7 = D_8 = D_9 = BY 255$
 $D_{10} = D_{19} = D_{23} = D_{24} = 1N4004$
 $D_{11} = D_{12} = D_{13} = D_{14} = D_{15} = D_{16} = 1N4148$
 $D_{17} = D_{18} = D_{20} = D_{21} = D_{22} = 1N4148$
 $D_{25} = D_{26} = D_{27} = D_{28} = D_{29} = D_{30} = 1N4148$
 $Tr_1 = Tr_2 = Tr_3 = Tr_6 = Tr_7 = BC 547$
 $Tr_4 = Tr_5 = BF 245$
 $Ic_1 = LM 78L05$
 $Tr_2 = PIV 12C508A$
 $Xtal = 4,0 \text{ MHz}$
 $V_1 = V_2 = V_3 = V_4 = EL 509 - EL 519$
 $L_1 = \text{RF impedance block}$
 $L_2 = L_3 = L_4 = L_5 = 3 \text{ turns wound on resistor, wire } \phi 0.8 \text{ mm}$
 $L_6 = L_7 = L_8 = L_9 = 3 \text{ turns } \phi 6 \text{ mm wire } \phi 0.8 \text{ mm}$
 $L_{10} = 9 \text{ turns } \phi 15 \text{ mm wire } \phi 2,0 \text{ mm tap } 4^a \text{ turn}$
 $L_{11} = 3 \text{ turns } \phi 34 \text{ mm wire } \phi 3,0 \text{ mm}$
 $RI_1 = RI_3 = \text{Relè } 12 \text{ V } 3022$
 $RI_2 = \text{Relè } 12 \text{ V } 6023$
 $F_1 = 16 \text{ A}$
 $F_2 = 4 \text{ A}$
 $F_3 = 2 \text{ A}$
 $Lamp_1 = Lamp_2 = \text{Meters lamp}$
 $Lamp_3 = 24 \text{ V}$
 $S_1 = \text{Switch (ON - OFF)}$
 $S_2 = \text{Switch (HI1 - HI2)}$
 $S_3 = \text{Switch (LOW - HI)}$
 $S_4 = \text{Protection Switch}$
 $S_5 = \text{Switch (DIR - CAL)}$
 $S_6 = \text{Switch } 3A \text{ (St.By - ON)}$
 $S_7 = \text{Switch } 3A \text{ (AM - SSB)}$
 $S_8 = \text{Switch } 3A \text{ (Pre ON - OFF)}$
 $T_1 = \text{Transformator IN } 110 \text{ OUT } 0-200-250-300V \text{ } 0-12 \text{ V } 0 - 6 \text{ V}$
 $T_2 = T_3 = \text{Transformers } 30 \text{ MHz}$
 $Fan = \text{Fan } 110 \text{ Vac}$