

Mod. KLV 1000 P linear amplifier

Schematic diagram

Version 3.11

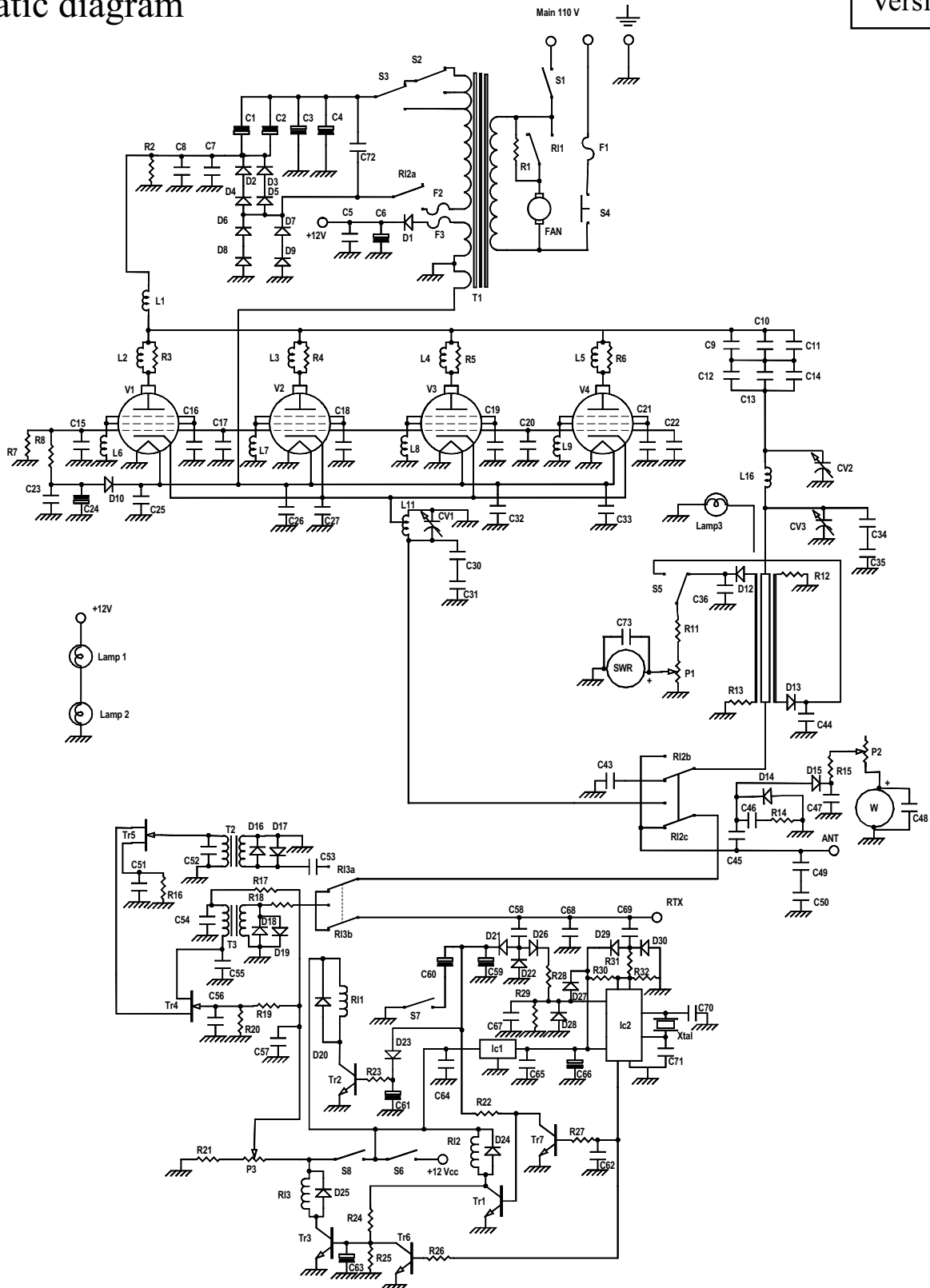

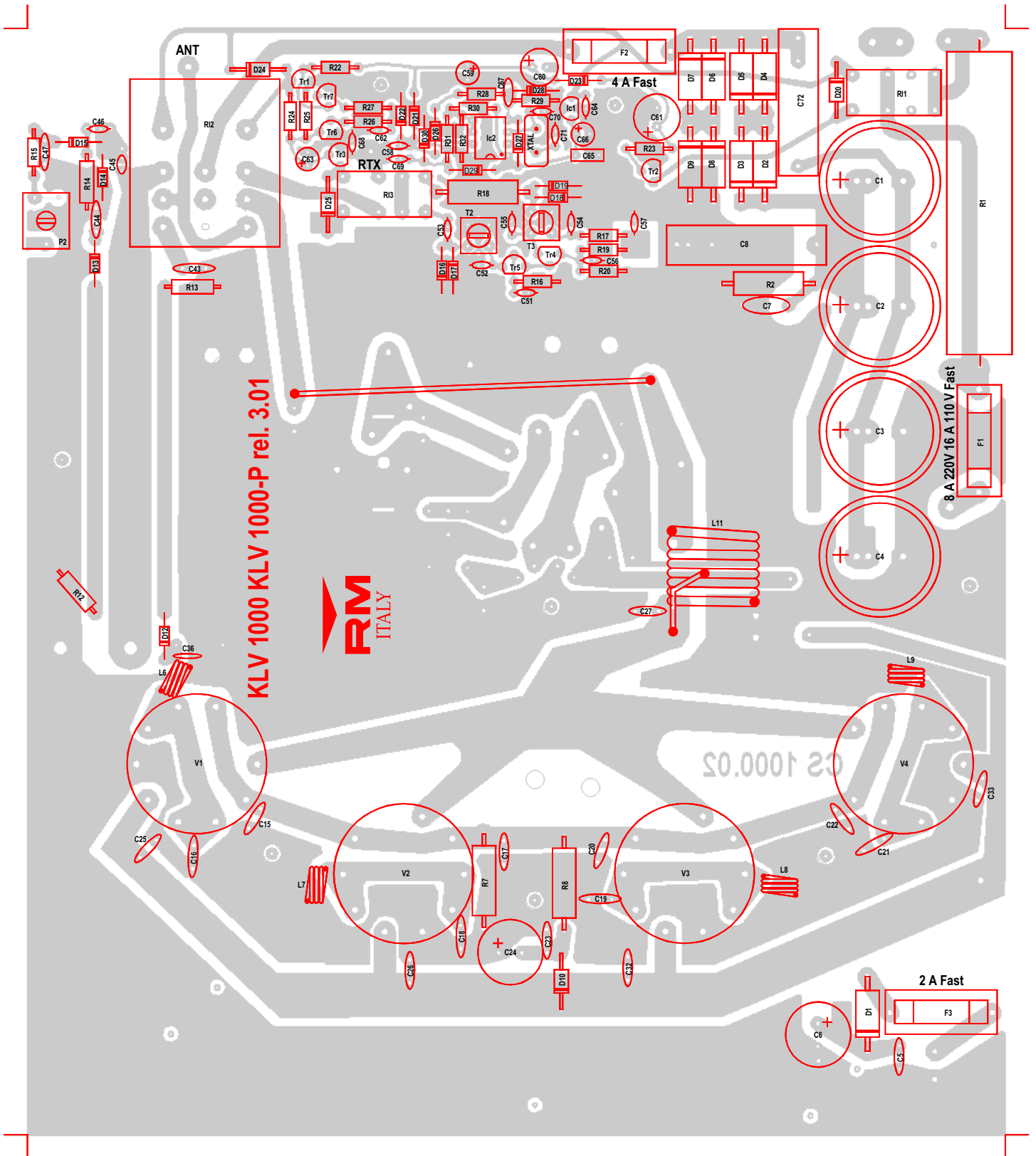

List of components

C ₁	= 100 µF	450 V	
C ₂	= 100 µF	450 V	
C ₃	= 100 µF	450 V	
C ₄	= 100 µF	450 V	
C ₅	= 100 nF	50V	
C ₆	= 2200 µF	16 V	
C ₇	= 2,2 nF	1500V	
C ₈	= 22 nF	1000 V	polyester
C ₉	= 2,2 nF	1500 V	
C ₁₀	= 2,2 nF	1500 V	
C ₁₁	= 2,2 nF	1500 V	
C ₁₂	= 2,2 nF	1500 V	
C ₁₃	= 2,2 nF	1500 V	
C ₁₄	= 2,2 nF	1500 V	
C ₁₅	= 100 nF	50V	
C ₁₆	= 150 pF	500 V	N750
C ₁₇	= 100 nF	50V	
C ₁₈	= 150 pF	500 V	N750
C ₁₉	= 150 pF	500 V	N750
C ₂₀	= 100 nF	50V	
C ₂₁	= 150 pF	500 V	N750
C ₂₂	= 100 nF	50V	
C ₂₃	= 100 nF	50V	
C ₂₄	= 470 µF	50 V	
C ₂₅	= 100 nF	50 V	
C ₂₆	= 100 nF	50 V	
C ₂₇	= 82 pF	500 V	N750
C ₃₀	= 100 pF	500 V	N750
C ₃₁	= 100 pF	500 V	N750
C ₃₂	= 100 nF	50 V	
C ₃₃	= 100 nF	50 V	
C ₃₄	= 220 pF	500 V	N750
C ₃₅	= 220 pF	500 V	N750
C ₃₆	= 100 nF	50 V	
C ₄₃	= 470 pF	50 V	N750
C ₄₄	= 100 nF	50 V	
C ₄₅	= 2,2 pF	50 V	N750
C ₄₆	= 33 pF	50 V	N750
C ₄₇	= 100 nF	50 V	
C ₄₈	= 100 nF	50 V	
C ₄₉	= 68 pF	500 V	N750
C ₅₀	= 68 pF	500 V	N750
C ₅₁	= 10 nF	50V	
C ₅₂	= 27 pF	50 V	N750
C ₅₃	= 10 nF	50V	
C ₅₄	= 10 nF	50V	
C ₅₅	= 33 pF	50 V	N750
C ₅₆	= 10 nF	50V	
C ₅₇	= 100 nF	50V	
C ₅₈	= 2,2 pF	50 V	N750
C ₅₉	= 10 µF	16V	
C ₆₀	= 47 µF	16V	
C ₆₁	= 330 µF	16V	
C ₆₂	= 10 nF	50V	
C ₆₃	= 10 µF	16V	
C ₆₄	= 10 nF	50 V	
C ₆₅	= 100 nF	63 V	polyester
C ₆₆	= 22 µF	16 V	
C ₆₇	= 10 nF	50 V	
C ₆₈	= 27 pF	50 V	N750
C ₆₉	= 1,0 pF	50 V	N750
C ₇₀	= 27 pF	50 V	N750
C ₇₁	= 27 pF	50 V	N750
C ₇₂	= 470 nF	630 V~	
C ₇₃	= 100 nF	50V	
C _{v1}	= Variable condensator	50 pF	
C _{v2}	= Variable condensator	50 pF	
C _{v3}	= Variable condensator	350 pF	
R ₁	= 820 Ω	17W	
R ₂	= 470 KΩ	2W	
R ₃	= 47 Ω	5W	
R ₄	= 47 Ω	5W	
R ₅	= 47 Ω	5W	
R ₆	= 47 Ω	5W	
R ₇	= 1,0 KΩ	2W	
R ₈	= 100 Ω	2W	
R ₁₁	= 47 KΩ	¼W	
R ₁₂	= 100 Ω	½W	
R ₁₃	= 100 Ω	½W	
R ₁₄	= 27 Ω	½W	
R ₁₅	= 47 KΩ	¼W	
R ₁₆	= 180 Ω	¼W	
R ₁₇	= 470 Ω	¼W	
R ₁₈	= 15 Ω	2W	
R ₁₉	= 56 KΩ	¼W	
R ₂₀	= 22 KΩ	¼W	
R ₂₁	= 4,7 KΩ	¼W	
R ₂₂	= 2,2 KΩ	¼W	
R ₂₃	= 2,2 KΩ	¼W	
R ₂₄	= 12 KΩ	¼W	
R ₂₅	= 680 Ω	¼W	
R ₂₆	= 1,0 KΩ	¼W	
R ₂₇	= 1,0 KΩ	¼W	
R ₂₈	= 56 KΩ	¼W	
R ₂₉	= 1,0 MΩ	¼W	

$R_{30} = 10\text{ K}\Omega \quad \frac{1}{4}\text{W}$
 $R_{31} = 100\ \Omega \quad \frac{1}{4}\text{W}$
 $R_{32} = 10\text{ K}\Omega \quad \frac{1}{4}\text{W}$
 $P_1 = \text{Potentiometer } 4,7\text{ K}\Omega$
 $P_2 = \text{Trimmer } 220\text{ K}\Omega$
 $P_3 = \text{Potentiometer } 4,7\text{ K}\Omega$
 $D_1 = 1\text{N}5400$
 $D_2 = D_3 = D_4 = D_5 = \text{BY } 255$
 $D_6 = D_7 = D_8 = D_9 = \text{BY } 255$
 $D_{10} = D_{20} = D_{24} = D_{25} = 1\text{N}4004$
 $D_{12} = D_{13} = D_{14} = D_{15} = D_{16} = 1\text{N}4148$
 $D_{17} = D_{18} = D_{19} = D_{21} = D_{22} = D_{23} = 1\text{N}4148$
 $D_{26} = D_{27} = D_{28} = D_{29} = D_{30} = 1\text{N}4148$
 $\text{Tr } 1 = \text{Tr } 2 = \text{Tr } 3 = \text{Tr } 6 = \text{Tr } 7 = \text{BC } 547$
 $\text{Tr } 4 = \text{Tr } 5 = \text{BF } 245$
 $\text{Ic } 1 = \text{LM } 78\text{L}05$
 $\text{Ic } 2 = \text{PIC } 12\text{C}508\text{A}$
 $\text{Xtal} = 4,0\text{ MHz}$
 $V_1 = V_2 = V_3 = V_4 = \text{EL } 509 - \text{EL } 519$
 $L_1 = L_{18} = \text{RF impedance block}$
 $L_2 = L_3 = L_4 = L_5 = 3\text{ turns wound on resistor, wire } \phi 0,8\text{ mm}$
 $L_6 = L_7 = L_8 = L_9 = 3\text{ turns } \phi 6\text{ mm wire } \phi 0,8\text{ mm}$
 $L_{11} = 9\text{ turns } \phi 15\text{ mm wire } \phi 2,0\text{ mm tap } 4^{\text{a}}\text{ turn}$
 $L_{16} = 3\text{ turns } \phi 34\text{ mm wire } \phi 3,0\text{ mm}$
 $\text{Rl } 1 = \text{Rl } 3 = \text{Relè } 12\text{ V } 3022$
 $\text{Rl } 2 = \text{Relè } 12\text{ V } 6043$
 $F_1 = 16\text{ A}$
 $F_2 = 4\text{ A}$
 $F_3 = 2\text{ A}$
 $\text{Lamp } 1 = \text{Lamp } 2 = \text{Meters lamp}$
 $\text{Lamp } 3 = 24\text{ V}$
 $S_1 = \text{Switch (ON - OFF)}$
 $S_2 = \text{Switch (HI1 - HI2)}$
 $S_3 = \text{Switch (LOW - HI)}$
 $S_4 = \text{Protection Switch}$
 $S_5 = \text{Switch (DIR - CAL)}$
 $S_6 = \text{Switch } 3\text{A (St.By - ON)}$
 $S_7 = \text{Switch } 3\text{A (AM - SSB)}$
 $S_8 = \text{Switch } 3\text{A (Pre ON - OFF)}$
 $T_1 = \text{Transformator IN } 110$
 $\quad \quad \quad \text{OUT } 0-200-250-300\text{V } 0 - 12\text{ V } 0 - 6\text{ V}$
 $T_2 = T_3 = \text{Transformers } 30\text{ MHz}$
 $\text{Fan} = \text{Fan } 110\text{ Vac}$