



RM

Costruzioni Elettroniche

di Marchioni Davide & Daniele s.n.c.

Via IV Novembre 215/5

Casella postale N° 33

40045 Ponte della Venturina (BO) ITALY

Tel +39 0534 60460

Fax +39 0534 60463

E-MAIL ufftec@rmitaly.com

<http://www.rmitaly.com>

Mod. KLV 1000 linear amplifier

Schematic diagram

Version 4.00

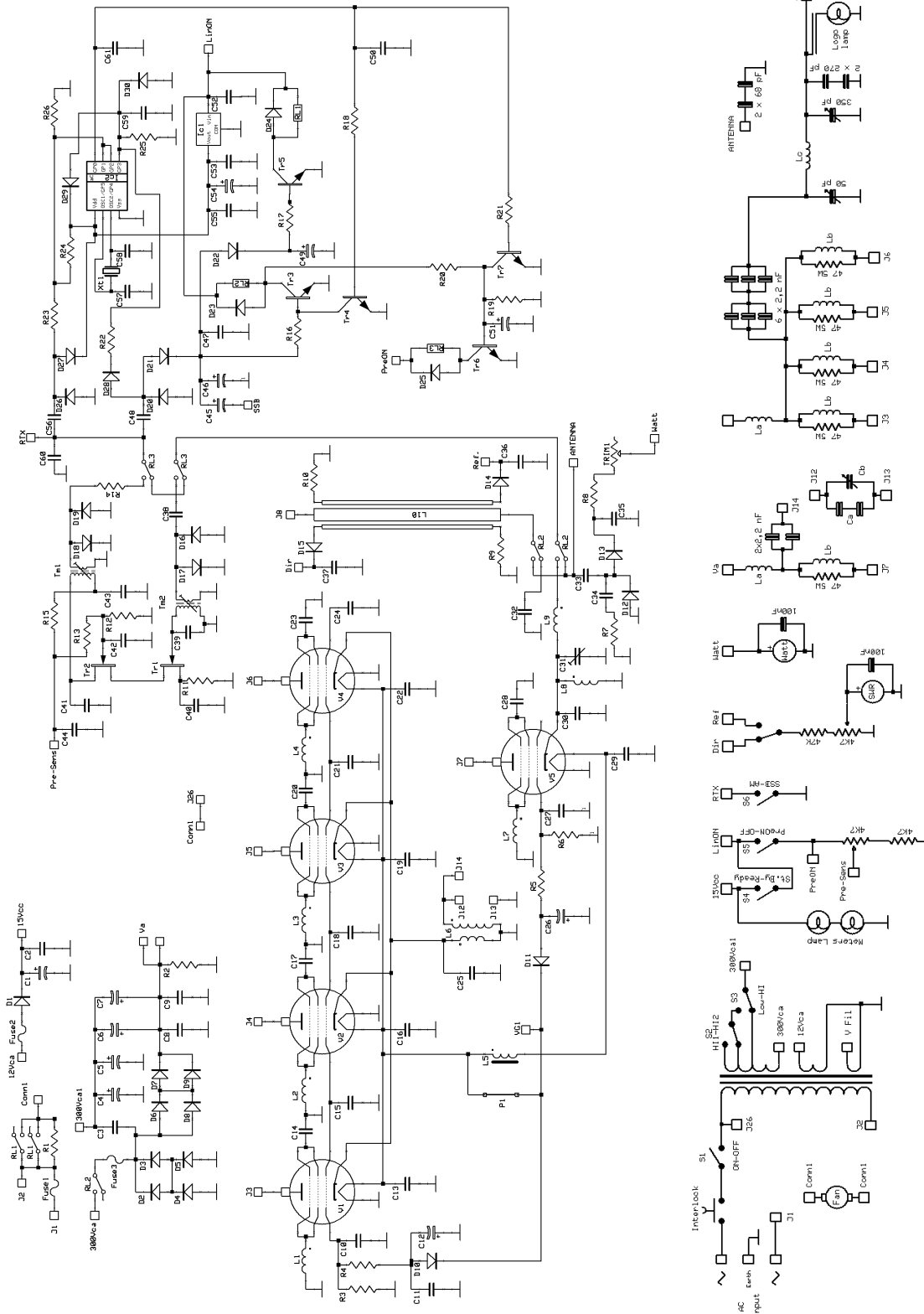

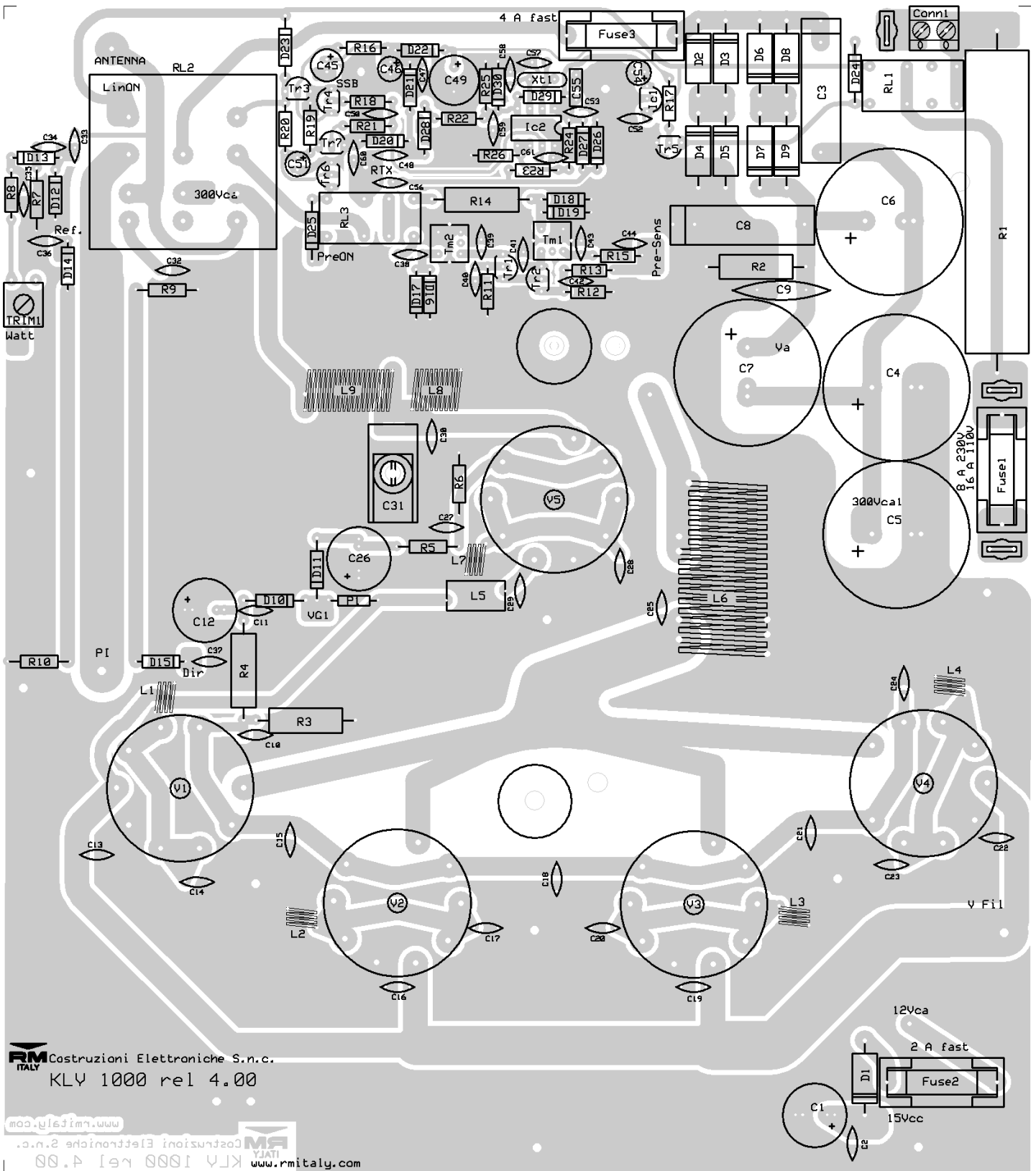

RM ITALY Costruzioni Elettroniche S.n.c.
KLV 1000 rel 4.00

www.rmitaly.com
Costruzioni Elettroniche S.n.c.
KLV 1000 rel 4.00 www.rmitaly.com

List of components

C 1 = 2200 μ F 25 V	C 6 = 100 μ F 450 V
C 2 = 100 nF 50V	C 7 = 100 μ F 450 V
C 3 = 470 nF 630 V~	C 8 = 22 nF 1000 V polyester
C 4 = 100 μ F 450 V	C 9 = 6,8 nF 1500 V
C 5 = 100 μ F 450 V	C 10 = 100 nF 50V

C ₁₁ = 100 nF	50V		C ₆₁ = 10 nF	50V	
C ₁₂ = 470 µF	50 V		Ca = 2 x 22 pF	500V	N750
C ₁₃ = 100 nF	50V		Cb = Variable	condensator	30 pF
C ₁₄ = 150 pF	500 V	N750	R ₁ = 2,2 KΩ	17W (220-240 V)	
C ₁₅ = 100 nF	50V		R ₁ = 820 Ω	17W (110 V)	
C ₁₆ = 100 nF	50V		R ₂ = 470 KΩ	2W	
C ₁₇ = 150 pF	500 V	N750	R ₃ = 1,0 KΩ	2W	
C ₁₈ = 100 nF	50V		R ₄ = 100 Ω	2W	
C ₁₉ = 100 nF	50V		R ₅ = 1,0 KΩ	½W	
C ₂₀ = 150 pF	500 V	N750	R ₆ = 1,0 KΩ	½W	
C ₂₁ = 100 nF	50V		R ₇ = 27 Ω	½W	
C ₂₂ = 100 nF	50V		R ₈ = 100 KΩ	¼W	
C ₂₃ = 150 pF	500 V	N750	R ₉ = 100 Ω	½W	
C ₂₄ = 100 nF	50V		R ₁₀ = 100 Ω	½W	
C ₂₅ = Not Present			R ₁₁ = 180 Ω	¼W	
C ₂₆ = 470 µF	50 V		R ₁₂ = 22 KΩ	¼W	
C ₂₇ = 100 nF	50V		R ₁₃ = 56 KΩ	¼W	
C ₂₈ = 150 pF	500 V	N750	R ₁₄ = 15 Ω	2W	
C ₂₉ = 100 nF	50V		R ₁₅ = 470 Ω	¼W	
C ₃₀ = 100 pF	50V	N750	R ₁₆ = 2,2 KΩ	¼W	
C ₃₁ = 10-80 pF	Trimmer		R ₁₇ = 2,2 KΩ	¼W	
C ₃₂ = 470 pF	50 V	N750	R ₁₈ = 1,0 KΩ	¼W	
C ₃₃ = 2,2 pF	50 V	N750	R ₁₉ = 680 Ω	¼W	
C ₃₄ = 33 pF	50 V	N750	R ₂₀ = 12 KΩ	¼W	
C ₃₅ = 100 nF	50 V		R ₂₁ = 1,0 KΩ	¼W	
C ₃₆ = 100 nF	50 V		R ₂₂ = 56 KΩ	¼W	
C ₃₇ = 100 nF	50 V		R ₂₃ = 100 Ω	¼W	
C ₃₈ = 10 nF	50 V		R ₂₄ = 10 KΩ	¼W	
C ₃₉ = 27 pF	50 V	N750	R ₂₅ = 1,0 MΩ	¼W	
C ₄₀ = 10 nF	50 V		R ₂₆ = 10 KΩ	¼W	
C ₄₁ = 33 pF	50 V	N750	P ₁ = 0 Ω	Bridge	
C ₄₂ = 10 nF	50 V		TRIM ₁ = 220 KΩ		
C ₄₃ = 10 nF	50 V		D ₁ = 1N5400		
C ₄₄ = 100 nF	50 V		D ₂ = D ₃ = D ₄ = D ₅ = BY 255		
C ₄₅ = 47 µF	16V		D ₆ = D ₇ = D ₈ = D ₉ = BY 255		
C ₄₆ = 10 µF	16V		D ₁₀ = D ₂₃ = D ₂₄ = D ₂₅ = 1N4007		
C ₄₇ = 100 nF	50 V		D ₁₁ = 1N4007		
C ₄₈ = 8,2 pF	50 V	N750	D ₁₂ = D ₁₃ = D ₁₄ = D ₁₅ = D ₁₆ = 1N4148		
C ₄₉ = 330 µF	16V		D ₁₇ = D ₁₈ = D ₁₉ = D ₂₀ = D ₂₁ = D ₂₂ = 1N4148		
C ₅₀ = 10 nF	50 V		D ₂₆ = D ₂₇ = D ₂₈ = D ₂₉ = D ₃₀ = 1N4148		
C ₅₁ = 10 µF	16V		Tr ₁ = Tr ₂ = BF 245		
C ₅₂ = 100 nF	50 V		Tr ₃ = BC 337		
C ₅₃ = 100 nF	50 V		Tr ₄ = Tr ₅ = Tr ₆ = Tr ₇ = BC 547		
C ₅₄ = 22 µF	16V		Ic ₁ = LM 78L05		
C ₅₅ = 100 nF	63 V	polyester	Ic ₂ = PIC 12C508A (RM1)		
C ₅₆ = 3,3 pF	50 V	N750	Xt ₁ = 4,0 MHz		
C ₅₇ = 27 pF	50 V	N750	V ₁ = V ₂ = V ₃ = V ₄ = EL 509 - EL 519		
C ₅₈ = 27 pF	50 V	N750	V ₅ = EL 509 - EL 519		
C ₅₉ = 10 nF	50 V		L ₁ = L ₂ = L ₃ = L ₄ = ANRA 309/2		
C ₆₀ = 27 pF	50 V	N750	L ₅ = VK 200		

L₇ = ANRA 309/2
L₈ = ANRA 309/1
L₉ = ANRA 309
L₆ = ACC-KLV1000
L₁₀ = On circuit
La = RF block Impedance
Lb = 3 turns wound on resistor wire \varnothing 0.8 mm
Lc = 3 turns \varnothing 34 mm wire \varnothing 3,0 mm
Rl₁ = Rl₃ = Relè 12 V 3022
Rl₂ = Relè 12 V 6223
Fuse₁ = 8 A (220-240 V)
Fuse₁ = 16 A (110 V)
Fuse₂ = 2 A
Fuse₃ = 4 A
Tm₁ = Tm₂ = Transformers 6835