

# Mod. KLV 1000 linear amplifier

Schematic diagram

Version 3.10

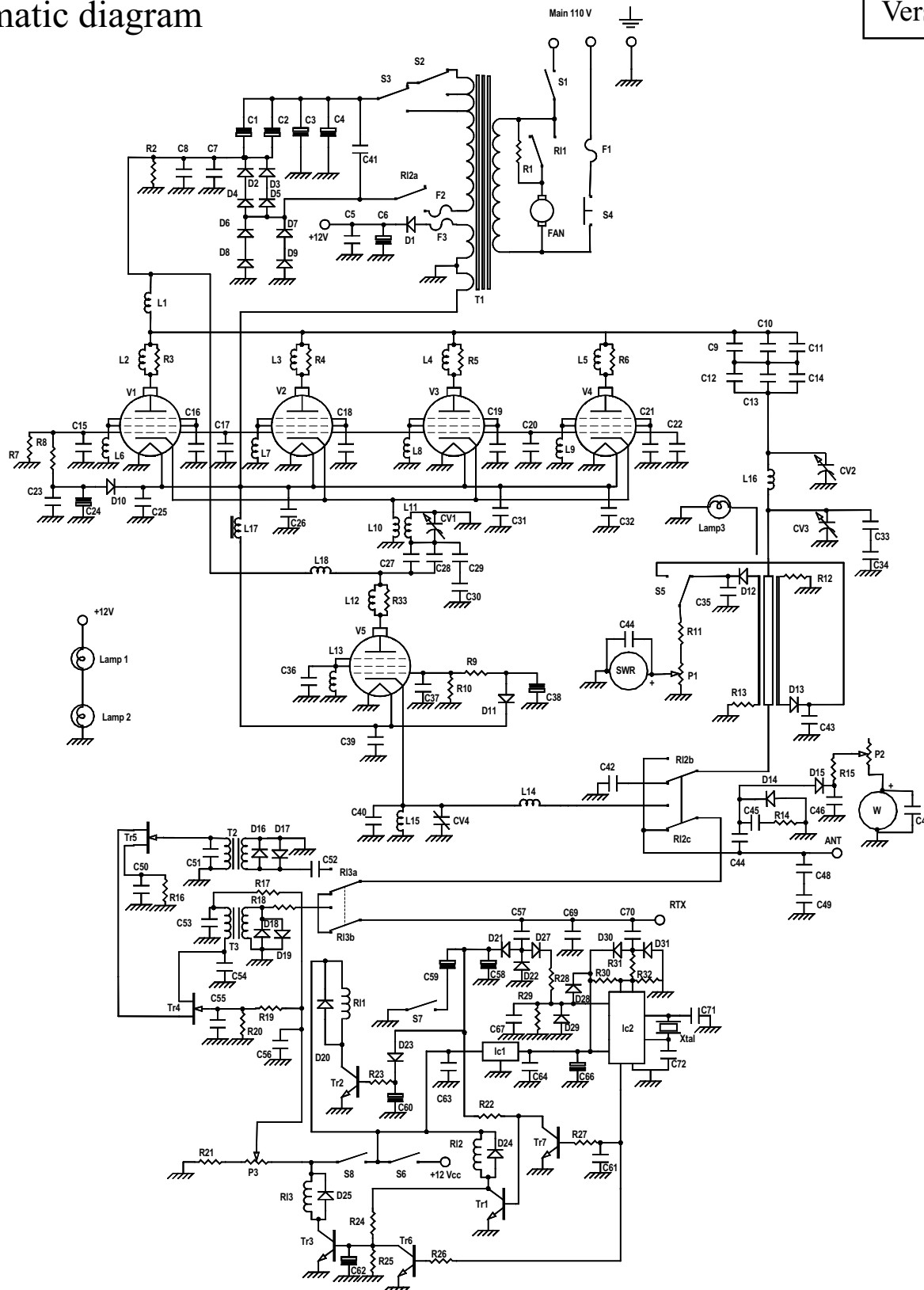

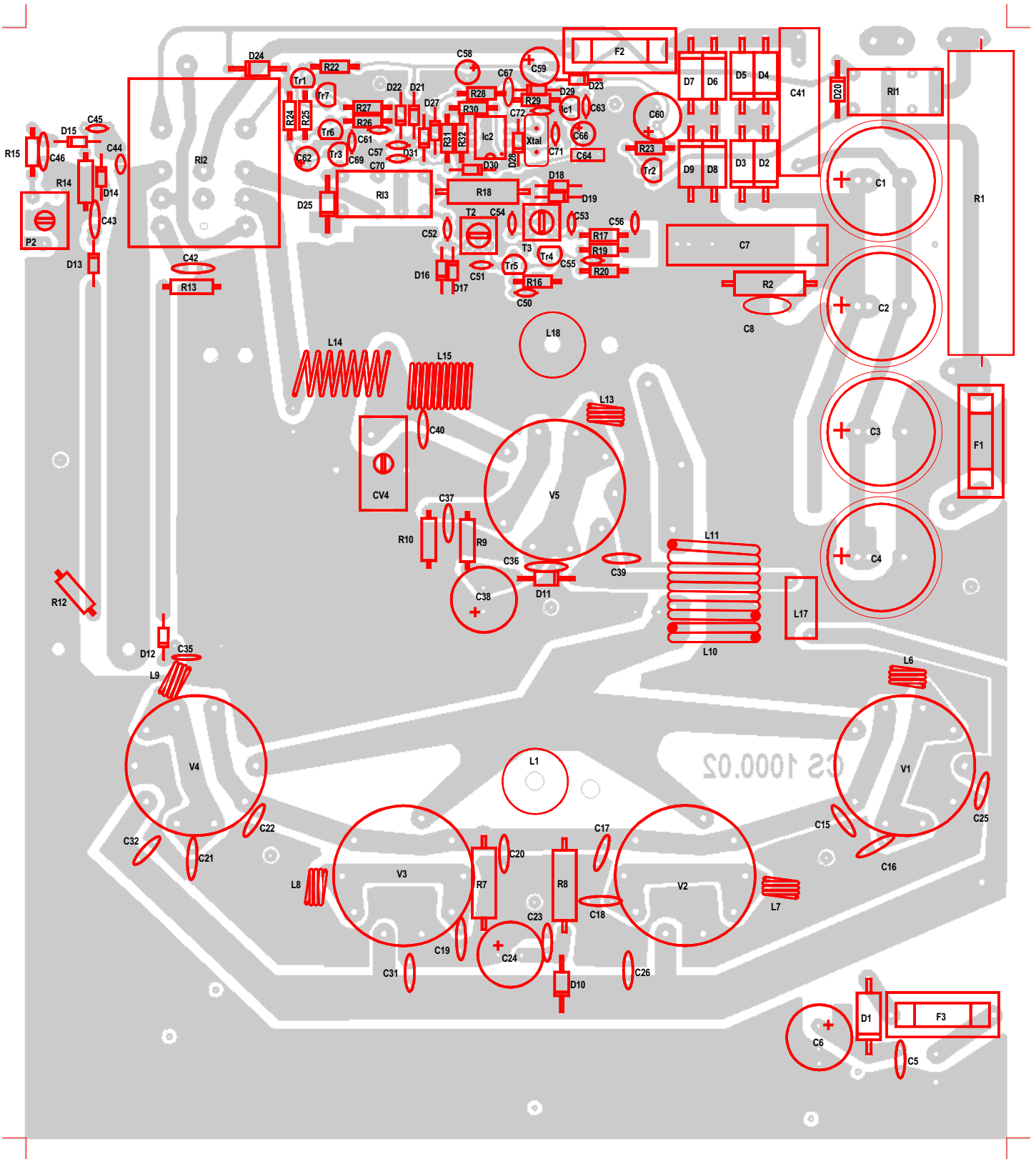

## List of components

C <sub>1</sub>	= 100 µF	450 V	
C <sub>2</sub>	= 100 µF	450 V	
C <sub>3</sub>	= 100 µF	450 V	
C <sub>4</sub>	= 100 µF	450 V	
C <sub>5</sub>	= 100 nF	50V	
C <sub>6</sub>	= 2200 µF	16 V	
C <sub>7</sub>	= 2,2 nF	1500V	
C <sub>8</sub>	= 22 nF	1000 V	polyester
C <sub>9</sub>	= 2,2 nF	1500 V	
C <sub>10</sub>	= 2,2 nF	1500 V	
C <sub>11</sub>	= 2,2 nF	1500 V	
C <sub>12</sub>	= 2,2 nF	1500 V	
C <sub>13</sub>	= 2,2 nF	1500 V	
C <sub>14</sub>	= 2,2 nF	1500 V	
C <sub>15</sub>	= 100 nF	50V	
C <sub>16</sub>	= 150 pF	500 V	N750
C <sub>17</sub>	= 100 nF	50V	
C <sub>18</sub>	= 150 pF	500 V	N750
C <sub>19</sub>	= 150 pF	500 V	N750
C <sub>20</sub>	= 100 nF	50V	
C <sub>21</sub>	= 150 pF	500 V	N750
C <sub>22</sub>	= 100 nF	50V	
C <sub>23</sub>	= 100 nF	50V	
C <sub>24</sub>	= 470 µF	50 V	
C <sub>25</sub>	= 100 nF	50 V	
C <sub>26</sub>	= 100 nF	50 V	
C <sub>27</sub>	= 2,2 nF	1500 V	
C <sub>28</sub>	= 2,2 nF	1500 V	
C <sub>29</sub>	= 22 pF	500 V	N750
C <sub>30</sub>	= 22 pF	500 V	N750
C <sub>31</sub>	= 100 nF	50 V	
C <sub>32</sub>	= 100 nF	50 V	
C <sub>33</sub>	= 270 pF	500 V	N750
C <sub>34</sub>	= 270 pF	500 V	N750
C <sub>35</sub>	= 100 nF	50 V	
C <sub>36</sub>	= 150 pF	500 V	N750
C <sub>37</sub>	= 100 nF	50 V	
C <sub>38</sub>	= 470 µF	50 V	
C <sub>39</sub>	= 100 nF	50 V	
C <sub>40</sub>	= 100 pF	50 V	N750
C <sub>41</sub>	= 470 nF	630 V~	
C <sub>42</sub>	= 470 pF	50 V	N750
C <sub>43</sub>	= 100 nF	50 V	
C <sub>44</sub>	= 2,2 pF	50 V	N750
C <sub>45</sub>	= 33 pF	50 V	N750
C <sub>46</sub>	= 100 nF	50 V	
C <sub>47</sub>	= 100 nF	50 V	
C <sub>48</sub>	= 68 pF	500 V	N750
C <sub>49</sub>	= 68 pF	500 V	N750
C <sub>50</sub>	= 10 nF	50V	
C <sub>51</sub>	= 27 pF	50 V	N750
C <sub>52</sub>	= 10 nF	50V	
C <sub>53</sub>	= 10 nF	50V	
C <sub>54</sub>	= 33 pF	50 V	N750
C <sub>55</sub>	= 10 nF	50V	
C <sub>56</sub>	= 100 nF	50V	
C <sub>57</sub>	= 8,2 pF	50 V	N750
C <sub>58</sub>	= 10 µF	16V	
C <sub>59</sub>	= 47 µF	16V	
C <sub>60</sub>	= 330 µF	16V	
C <sub>61</sub>	= 10 nF	50V	
C <sub>62</sub>	= 10 µF	16V	
C <sub>63</sub>	= 10 nF	50 V	
C <sub>64</sub>	= 100 nF	63 V	polyester
C <sub>66</sub>	= 22 µF	16 V	
C <sub>67</sub>	= 10 nF	50 V	
C <sub>69</sub>	= 27 pF	50 V	N750
C <sub>70</sub>	= 3,3 pF	50 V	N750
C <sub>71</sub>	= 27 pF	50 V	N750
C <sub>72</sub>	= 27 pF	50 V	N750
Cv <sub>1</sub>	= Variable condensator	30 pF	
Cv <sub>2</sub>	= Variable condensator	50 pF	
Cv <sub>3</sub>	= Variable condensator	350 pF	
Cv <sub>4</sub>	= Trimmer	10 - 100 pF	
R <sub>1</sub>	= 820 Ω	17W	
R <sub>2</sub>	= 470 KΩ	2W	
R <sub>3</sub>	= 47 Ω	5W	
R <sub>4</sub>	= 47 Ω	5W	
R <sub>5</sub>	= 47 Ω	5W	
R <sub>6</sub>	= 47 Ω	5W	
R <sub>7</sub>	= 1,0 KΩ	2W	
R <sub>8</sub>	= 100 Ω	2W	
R <sub>9</sub>	= 1,0 KΩ	½W	
R <sub>10</sub>	= 1,0 KΩ	½W	
R <sub>11</sub>	= 47 KΩ	¼W	
R <sub>12</sub>	= 100 Ω	½W	
R <sub>13</sub>	= 100 Ω	½W	
R <sub>14</sub>	= 27 Ω	½W	
R <sub>15</sub>	= 47 KΩ	¼W	
R <sub>16</sub>	= 180 Ω	¼W	
R <sub>17</sub>	= 470 Ω	¼W	
R <sub>18</sub>	= 15 Ω	2W	
R <sub>19</sub>	= 56 KΩ	¼W	
R <sub>20</sub>	= 22 KΩ	¼W	
R <sub>21</sub>	= 4,7 KΩ	¼W	

R<sub>22</sub> = 2,2 KΩ ¼W  
 R<sub>23</sub> = 2,2 KΩ ¼W  
 R<sub>24</sub> = 12 KΩ ¼W  
 R<sub>25</sub> = 680 Ω ¼W  
 R<sub>26</sub> = 1,0 KΩ ¼W  
 R<sub>27</sub> = 1,0 KΩ ¼W  
 R<sub>28</sub> = 56 KΩ ¼W  
 R<sub>29</sub> = 1,0 MΩ ¼W  
 R<sub>30</sub> = 10 KΩ ¼W  
 R<sub>31</sub> = 100 Ω ¼W  
 R<sub>32</sub> = 10 KΩ ¼W  
 R<sub>33</sub> = 47 Ω 5W  
 P<sub>1</sub> = Potentiometer 4,7 KΩ  
 P<sub>2</sub> = Trimmer 220 KΩ  
 P<sub>3</sub> = Potentiometer 4,7 KΩ  
 D<sub>1</sub> = 1N5400  
 D<sub>2</sub> = D<sub>3</sub> = D<sub>4</sub> = D<sub>5</sub> = BY 255  
 D<sub>6</sub> = D<sub>7</sub> = D<sub>8</sub> = D<sub>9</sub> = BY 255  
 D<sub>10</sub> = D<sub>11</sub> = D<sub>20</sub> = D<sub>24</sub> = D<sub>25</sub> = 1N4004  
 D<sub>12</sub> = D<sub>13</sub> = D<sub>14</sub> = D<sub>15</sub> = D<sub>16</sub> = 1N4148  
 D<sub>17</sub> = D<sub>18</sub> = D<sub>19</sub> = D<sub>21</sub> = D<sub>22</sub> = D<sub>23</sub> = 1N4148  
 D<sub>27</sub> = D<sub>28</sub> = D<sub>29</sub> = D<sub>30</sub> = D<sub>31</sub> = 1N4148  
 Tr<sub>1</sub> = Tr<sub>2</sub> = Tr<sub>3</sub> = Tr<sub>6</sub> = Tr<sub>7</sub> = BC 547  
 Tr<sub>4</sub> = Tr<sub>5</sub> = BF 245  
 Ic<sub>1</sub> = LM 78L05  
 Ic<sub>2</sub> = PIC 12C508A  
 Xtal = 4,0 MHz  
 V<sub>1</sub> = V<sub>2</sub> = V<sub>3</sub> = V<sub>4</sub> = V<sub>5</sub> = EL 509 - EL 519  
 L<sub>1</sub> = L<sub>18</sub> = RF impedance block  
 L<sub>2</sub> = L<sub>3</sub> = L<sub>4</sub> = L<sub>5</sub> = L<sub>12</sub> = 3 turns wound on resistor, wire φ 0.8 mm  
 L<sub>6</sub> = L<sub>7</sub> = L<sub>8</sub> = L<sub>9</sub> = L<sub>13</sub> = 3 turns φ 6 mm wire φ 0.8 mm  
 L<sub>10</sub> = 2 turns φ 15 mm wire φ 2,0 mm  
 L<sub>11</sub> = 6 turns φ 15 mm wire φ 2,0 mm  
 L<sub>14</sub> = 7 turns φ 8 mm wire φ 0,8 mm  
 L<sub>15</sub> = 9 turns φ 8 mm wire φ 0,8 mm  
 L<sub>16</sub> = 3 turns φ 34 mm wire φ 3,0 mm  
 L<sub>17</sub> = VK 200  
 Rl<sub>1</sub> = Rl<sub>3</sub> = Relè 12 V 3022  
 Rl<sub>2</sub> = Relè 12 V 6043  
 F<sub>1</sub> = 16 A  
 F<sub>2</sub> = 4 A  
 F<sub>3</sub> = 2 A  
 Lamp<sub>1</sub> = Lamp<sub>2</sub> = Meters lamp  
 Lamp<sub>3</sub> = 24 V  
 S<sub>1</sub> = Switch (ON - OFF)  
 S<sub>2</sub> = Switch (HI1 - HI2)  
 S<sub>3</sub> = Switch (LOW - HI)  
 S<sub>4</sub> = Protection Switch  
 S<sub>5</sub> = Switch (DIR - CAL)  
 S<sub>6</sub> = Switch 3A (St.By - ON)  
 S<sub>7</sub> = Switch 3A (AM - SSB)  
 S<sub>8</sub> = Switch 3A (Pre ON - OFF)  
 T<sub>1</sub> = Transformator IN 110  
 OUT 0-200-250-300V 0 - 12 V 0 - 6 V  
 T<sub>2</sub> = T<sub>3</sub> = Transformers 30 MHz  
 Fan = Fan 110 Vac