

Mod. KLV 1000 linear amplifier

Schematic diagram

Version 3.01

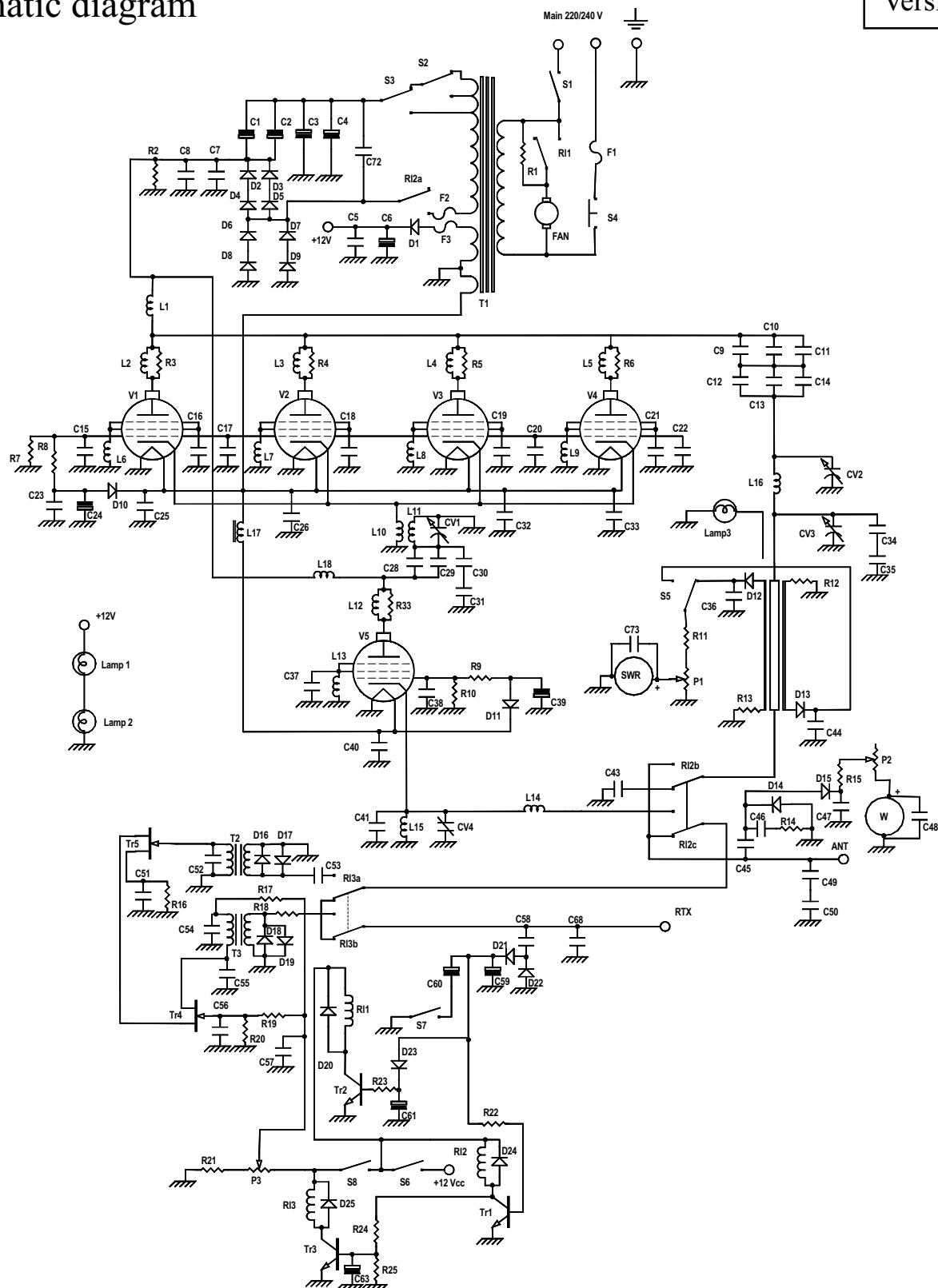

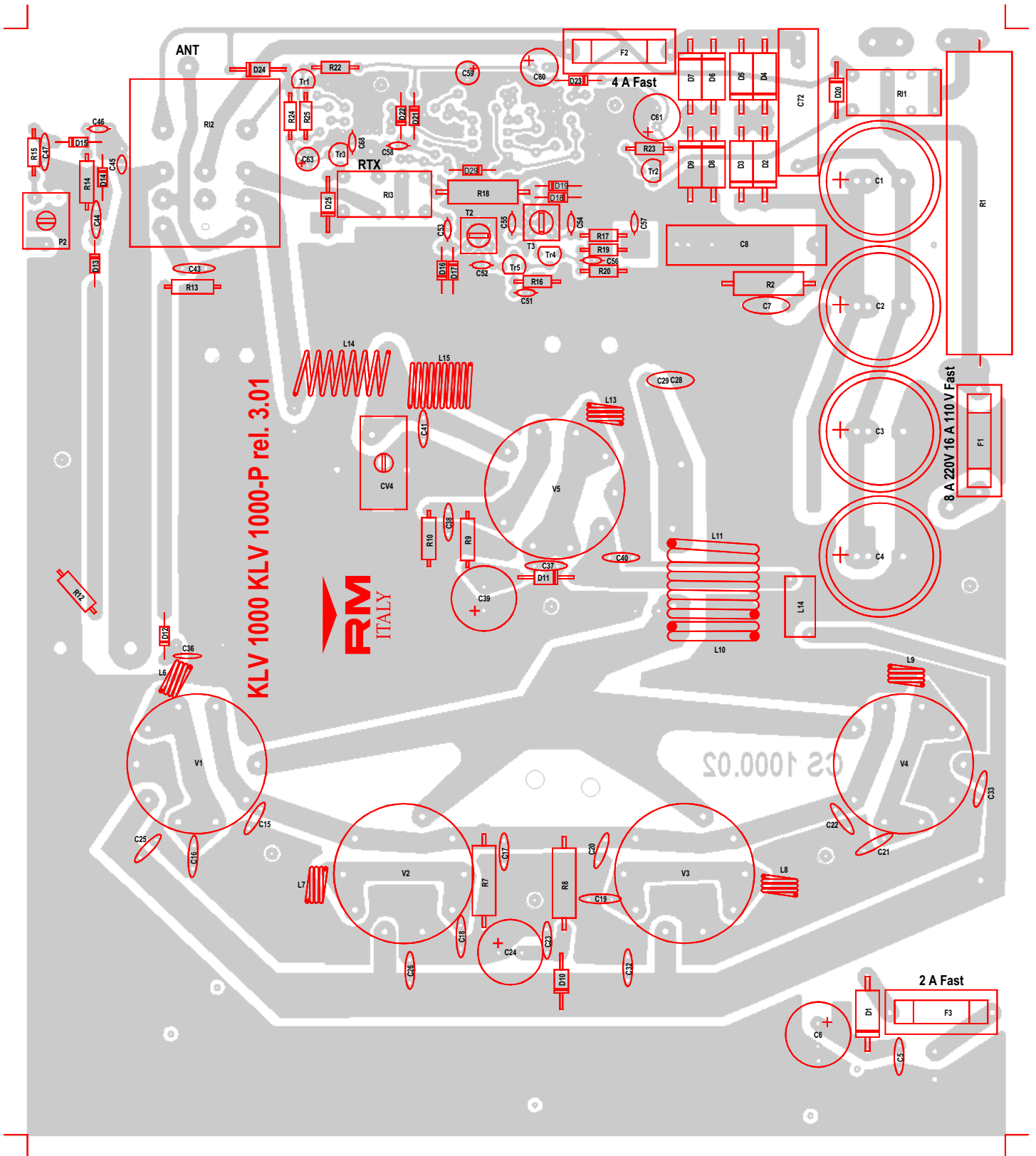

List of components

C ₁	= 100 µF	450 V		C ₅₁	= 10 nF	50V	
C ₂	= 100 µF	450 V		C ₅₂	= 27 pF	50 V	N750
C ₃	= 100 µF	450 V		C ₅₃	= 10 nF	50V	
C ₄	= 100 µF	450 V		C ₅₄	= 10 nF	50V	
C ₅	= 100 nF	50V		C ₅₅	= 33 pF	50 V	N750
C ₆	= 2200 µF	16 V		C ₅₆	= 10 nF	50V	
C ₇	= 2,2 nF	1500V		C ₅₇	= 100 nF	50V	
C ₈	= 22 nF	1000 V	polyester	C ₅₈	= 8,2 pF	50 V	N750
C ₉	= 2,2 nF	1500 V		C ₅₉	= 10 µF	16V	
C ₁₀	= 2,2 nF	1500 V		C ₆₀	= 47 µF	16V	
C ₁₁	= 2,2 nF	1500 V		C ₆₁	= 330 µF	16V	
C ₁₂	= 2,2 nF	1500 V		C ₆₂	= 10 nF	50V	
C ₁₃	= 2,2 nF	1500 V		C ₆₃	= 10 µF	16V	
C ₁₄	= 2,2 nF	1500 V		C ₆₈	= 27 pF	50 V	N750
C ₁₅	= 100 nF	50V		C ₇₂	= 470 nF	630 V~	
C ₁₆	= 150 pF	500 V	N750	C ₇₃	= 100 nF	50V	
C ₁₇	= 100 nF	50V		Cv ₁	= Variable condensator	30 pF	
C ₁₈	= 150 pF	500 V	N750	Cv ₂	= Variable condensator	50 pF	
C ₁₉	= 150 pF	500 V	N750	Cv ₃	= Variable condensator	350 pF	
C ₂₀	= 100 nF	50V		Cv ₄	= Trimmer	10 - 100 pF	
C ₂₁	= 150 pF	500 V	N750	R ₁	= 2,2 KΩ	15W	
C ₂₂	= 100 nF	50V		R ₂	= 470 KΩ	2W	
C ₂₃	= 100 nF	50V		R ₃	= 47 Ω	5W	
C ₂₄	= 470 µF	50 V		R ₄	= 47 Ω	5W	
C ₂₅	= 100 nF	50 V		R ₅	= 47 Ω	5W	
C ₂₆	= 100 nF	50 V		R ₆	= 47 Ω	5W	
C ₂₈	= 2,2 nF	1500 V		R ₇	= 1,0 KΩ	2W	
C ₂₉	= 2,2 nF	1500 V		R ₈	= 100 Ω	2W	
C ₃₀	= 22 pF	500 V	N750	R ₉	= 1,0 KΩ	½W	
C ₃₁	= 22 pF	500 V	N750	R ₁₀	= 1,0 KΩ	½W	
C ₃₂	= 100 nF	50 V		R ₁₁	= 47 KΩ	¼W	
C ₃₃	= 100 nF	50 V		R ₁₂	= 100 Ω	½W	
C ₃₄	= 220 pF	500 V	N750	R ₁₃	= 100 Ω	½W	
C ₃₅	= 220 pF	500 V	N750	R ₁₄	= 27 Ω	½W	
C ₃₆	= 100 nF	50 V		R ₁₅	= 47 KΩ	¼W	
C ₃₇	= 150 pF	500 V	N750	R ₁₆	= 180 Ω	¼W	
C ₃₈	= 100 nF	50 V		R ₁₇	= 470 Ω	¼W	
C ₃₉	= 470 µF	50 V		R ₁₈	= 15 Ω	2W	
C ₄₀	= 100 nF	50 V		R ₁₉	= 56 KΩ	¼W	
C ₄₁	= 100 pF	50 V	N750	R ₂₀	= 22 KΩ	¼W	
C ₄₃	= 470 pF	50 V	N750	R ₂₁	= 4,7 KΩ	¼W	
C ₄₄	= 100 nF	50 V		R ₂₂	= 2,2 KΩ	¼W	
C ₄₅	= 2,2 pF	50 V	N750	R ₂₃	= 2,2 KΩ	¼W	
C ₄₆	= 33 pF	50 V	N750	R ₂₄	= 12 KΩ	¼W	
C ₄₇	= 100 nF	50 V		R ₂₅	= 680 Ω	¼W	
C ₄₈	= 100 nF	50 V		R ₃₃	= 47 Ω	5W	
C ₄₉	= 68 pF	500 V	N750	P ₁	= Potentiometer	4,7 KΩ	
C ₅₀	= 68 pF	500 V	N750				

P₂ = Trimmer 220 KΩ
 P₃ = Potentiometer 4,7 KΩ
 D₁ = 1N5400
 D₂ = D₃ = D₄ = D₅ = BY 255
 D₆ = D₇ = D₈ = D₉ = BY 255
 D₁₀ = D₁₁ = D₂₀ = D₂₄ = D₂₅ = 1N4004
 D₁₂ = D₁₃ = D₁₄ = D₁₅ = D₁₆ = 1N4148
 D₁₇ = D₁₈ = D₁₉ = D₂₁ = D₂₂ = D₂₃ = 1N4148
 Tr₁ = Tr₂ = Tr₃ = BC 547
 Tr₄ = Tr₅ = BF 245
 V₁ = V₂ = V₃ = V₄ = V₅ = EL 509 - EL 519
 L₁ = L₁₈ = RF impedance block
 L₂ = L₃ = L₄ = L₅ = L₁₂ = 3 turns wound on resistor, wire φ 0.8 mm
 L₆ = L₇ = L₈ = L₉ = L₁₃ = 3 turns φ 6 mm wire φ 0.8 mm
 L₁₀ = 2 turns φ 15 mm wire φ 2,0 mm
 L₁₁ = 6 turns φ 15 mm wire φ 2,0 mm
 L₁₄ = 7 turns φ 8 mm wire φ 0,8 mm
 L₁₅ = 9 turns φ 8 mm wire φ 0,8 mm
 L₁₆ = 3 turns φ 34 mm wire φ 3,0 mm
 L₁₇ = VK 200
 Rl₁ = Rl₃ = Relè 12 V 3022
 Rl₂ = Relè 12 V 6043
 F₁ = 8 A
 F₂ = 4 A
 F₃ = 2 A
 Lamp₁ = Lamp₂ = Meters lamp
 Lamp₃ = 24 V
 S₁ = Switch (ON - OFF)
 S₂ = Switch (HI1 - HI2)
 S₃ = Switch (LOW - HI)
 S₄ = Protection Switch
 S₅ = Switch (DIR - CAL)
 S₆ = Switch 3A (St.By - ON)
 S₇ = Switch 3A (AM - SSB)
 S₈ = Switch 3A (Pre ON - OFF)
 T₁ = Transformator IN 220/240 V
 OUT 0-200-250-300V 0 - 12 V 0 - 6 V
 T₂ = T₃ = Transformers 30 MHz
 Fan = Fan 220 Vac