

AMPLIFICATORE LINEARE
LINEAR AMPLIFIER
AMPLIFICATEUR LINEAIRE
LINEARVERSTÄRKER
AMPLIFICADORES LINEAL

KL 243



Frequenza - Frequency - Fréquence - Frequenz - Frecuencia	42 - 47 MHz
Alimentazione - Supply - Alimentation - Versorgungsspannung - Alimentación	12 - 14 Vcc
Assorbimento - Input energy - Courant - Stromaufnahme - Consumo	8 - 11 A
Potenza d'ingresso - Input power - Puissance d'entrée - Eingangsleistung - Potencia de entrada	0,5-5 W FM 1-10 W SSB
Potenza d'uscita - Output power - Puissance de sortie - Ausgangsleistung - Potencia de salida	70 -100 W FM 140 - 200 W SSB
ROS ingrasso - Input SWR - TOS d'entrée -SWR betrieb bis -ROE de entrada	1.1 - 1.5
Funzionamento - Mode - Fonctionnement - Funktionen - Modos de emisión	FM SSB CW
fusibile - Fuse - Fusible - Sicherung - Fusible	12 A

Commutazione elettronica .

Protezione contro l'inversione di polarità.

Garanzia mesi 24 escluso transistor finale.

Il cavo di alimentazione deve essere inferiore ai 3 m. possibilmente collegato direttamente alla batteria e di sezione non inferiore a 2 mm².

Electronic switch.

Inversion polarity protection.

24 months warranty except final transistor.

The power cord has to be shorter than 3 m. with a section of at least 2 mm². If possible connect the power cord directly to the battery.

Commutateur électronique

Protege contre l'inversion de courant

Tet appareil a 24 mois de garantie, excepté le transistor final

Le câble électrique doit être inférieure à 3m. avec une section pas inférieure à 2 mm². Si possible branchez le câble directement à la batterie.

Elektronischer Schalter

Polaritätenschutz

24 Monate Garantie ausgenommen finale Transistoren

Das Stromkabel muss kürzer als 3 m. sein und eine Schnittfläche von mindestens 2 mm² aufweisen. Wenn möglich das Kabel direkt an der Batterie anschliessen.

Conmutación electrónica

Protección contra la inversion de polaridad.

Garantía: 24 meses, transistor final excluido.

El cable de alimentación debe ser inferior a 3 m., conectado si es posible directamente a la batería, y de sección no inferior a 2 mm².

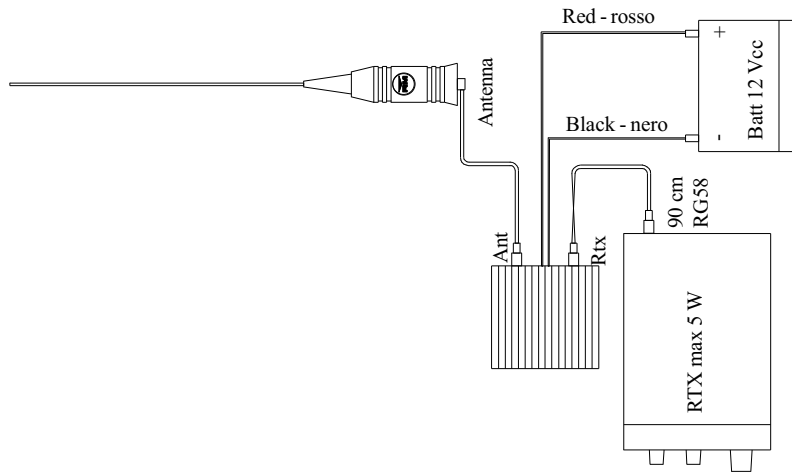
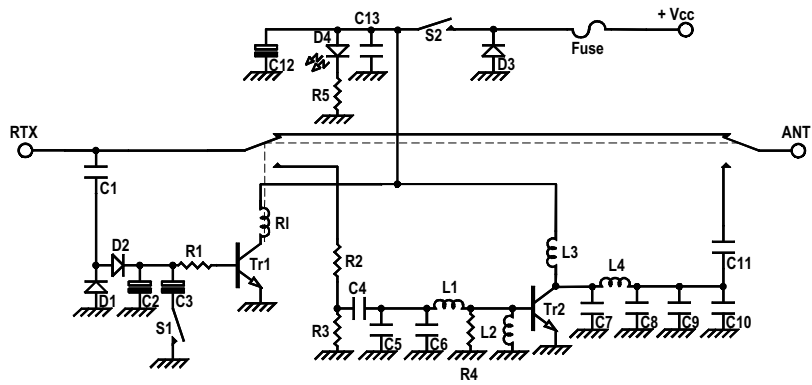

EC Certificate of conformity
(to EMC Directive 89/336/EEC)

This is to certify that:

The linear amplifier **KL 243**

complies with the provisions of the Directive of the Council of the European Communities on the approximation of the laws of the Member States relating to electromagnetic compatibility (EMC Directive 89/336/EEC).

This declaration of conformity of European Communities is the result of an examination carried out by the Quality Assurance Department of

RM Costruzioni elettroniche

in accordance with European Telecommunications Standards ETS 300 684 - 300 339, of December 1995.