

- ① Interruttore ON OFF - ON OFF switch - Interrupteur ON OFF - Schalter EIN/AUS
- ② Interruttore SSB-CW FM - SSB-CW FM switch - Interrupteur SSB-CW FM
- ③ Led indicatore di accensione - Switching on led indicator - Led indicator

d'allumage - Led einschaltungsanzeiger - Led indicador de encendido.

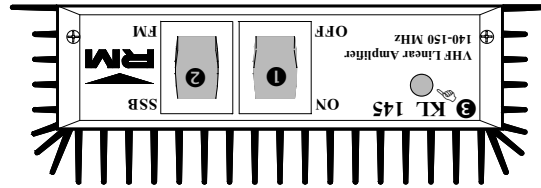

KL 145 - 145H

AMPLIFICATORE LINEARE
 LINEAR AMPLIFIER
 AMPLIFICATEUR LINEAIRE
 LINEARVÄRSTÄRKER
 AMPLIFICADORES LINEAL



EC Certificate of conformity
 (to EMC Directive 89/336/EEC)

This is to certify that:

The linear amplifier **KL145** and **KL 145H**

complies with the provisions of the Directive of the Council of the European Communities on the approximation of the laws of the Member States relating to electromagnetic compatibility (EMC Directive 89/336/EEC).

This declaration of conformity of European Communities is the result of an examination carried out by the Quality Assurance Department of

RM Costruzioni elettroniche

in accordance with European Telecommunications Standards ETS 300 684, of December 1995.

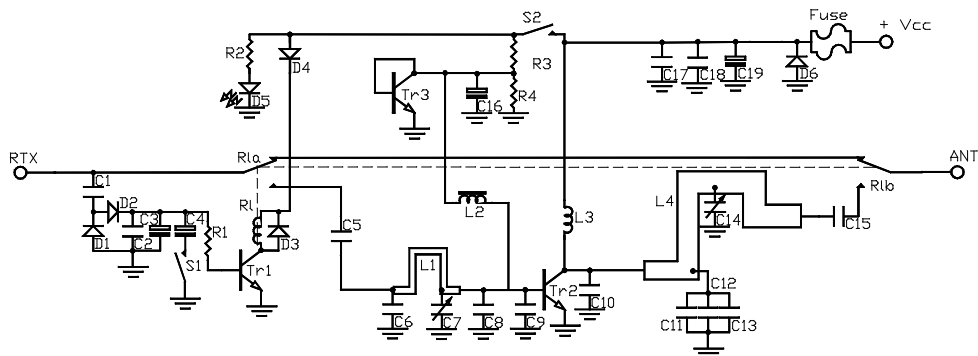

	KL	145	145H
Frequenza - Frequency - Fréquence - Freqenz - Frecuencia MHz		140 - 150	150 - 170
Alimentazione - Supply - Alimentation - Versorgungsspannung -			
	Alimentación:	12 - 14 Vcc	
Assorbimento - Input energy - Courant - Stromaufnahme - Consumo		14 A	
Potenza d'ingresso - Input power - Puissance d'entrée -			
	Eingangsleistung - Potencia de entrada	1-25 W FM	
		2-50 W SSB CW	
Potenza d'uscita - Output power - Puissance de sortie - Ausgangsleistung -			
	Potencia de salida	120 W max FM	
		240 W max SSB CW	
ROS ingrasso - Input SWR - TOS d'entrée -SWR betrieb bis -ROE de entrada		1.1 - 1.5	
Funzionamento - Mode - Fonctionnement - Funktionen - Modos de emisión		FM SSB CW	
fusibile - Fuse - Fusible - Sicherung - Fusible		2 x 8 A	

Commutazione elettronica. Protezione contro l'inversione di polarità.

Il cavo di alimentazione deve essere inferiore ai 3 m. possibilmente collegato direttamente alla batteria e di sezione non inferiore a 2,5 mm².

Garanzia mesi 24 escluso transistor finale.

Electronic switch. Inversion polarity protection.

The power cord has to be shorter that 3 m. with a section of at least 2,5 mm². If possible connect the power cord directly to the battery.

24 months warranty except final transistor.

Commutateur électronique. Protege contre l'inversion de courant.

Le câble électrique doit être inférieure à 3m. avec une section pas inférieure à 2,5 mm². Si possible branchez le câble directement à la batterie.

Tet appareil a 24 mois de garantie, excepté le transistor final.

Elektronischer Schalter. Polaritätenschutz.

Das Stromkabel muss kürzer als 3 m. sein und eine Schnittfläche von mindestens 2,5 mm² aufweisen. Wenn möglich das Kabel direkt an der Batterie anschliessen.

24 Monate Garantie ausgenommen finale Transistoren.

Commutación electrónica. Protección contra la inversion de polaridad.

El cable de alimentación debe ser inferior a 3 m., conectado si es posible directamente a la batería, y de sección no inferior a 2,5 mm².

Garantía: 24 meses, transistor final excluido.

