



ORDER NO.
644

INSTALLATION & OPERATION INSTRUCTIONS

FOOTWARMER AMATEUR RADIO AMPLIFIER

1.1 INTRODUCTION

The Hy-Gain Footwarmer Amplifier is a precision built amplifier of advanced design. It utilizes two tubes, two transistors in a tuned grid tuned plate circuit for amplification of AM, FM, CW and SSB signals.

The Footwarmer is designed for 117v AC 60 cycle base installation. It has a built-in automatic antenna change over relay, which operates without special external connections, making it perfect for operation with low power transceivers having no external amplifier control circuits.

The Footwarmer has been designed and constructed to suppress radiation that may cause television interference. TVI problem has been given full consideration in the design and the layout of the chassis. There are, however, some types of TVI that cannot be prevented within the amplifier. This is particularly true in weak signal areas. In such cases, a good commercial low pass filter is recommended.

1.2 TECHNICAL SPECIFICATIONS

Mechanical

Height (including feet) 5 9/16"
Width 14"
Depth 11 1/2"
Construction Lightweight aluminum chassis with rugged steel cover

Electrical

Frequency Range Amateur 10 meter band
Types of Emission AM, FM, CW, SSB, DSB
Power Output 200 watts AM with full upward modulation
Drive Required to Trigger Antenna Relay 1 watt
Max Drive (unmodulated carrier and FM) 5 watts
(amplitude modulated carrier) 3.5 watts
(amplitude modulated peak) 14 watts PEP
Input Impedance (unbalanced) 50 ohms nominal
Output Impedance (unbalanced) 50 ohms fixed
Antenna Switching Automatic provided by RF sensing circuit
Power Requirements 117v AC
Cable Connector Data Input & Output requires PL-259

SECTION II UNPACKING

2.1 UNPACKING

Carefully remove the Footwarmer Amplifier from the carton. Examine it closely for signs of shipping damage. If inspection shows damage the delivering carrier must be contacted immediately and a claim filed.

The responsibility for safe delivery rests with the carrier. The responsibility of obtaining reimbursement rests with

you. Prompt action will speed adjustment. Our warranty does not cover malfunction or damage which is a result of improper handling by a carrier.

2.2 WARRANTY REGISTRATION

Fill out the enclosed Warranty Card and mail immediately.

SECTION III INSTALLATION

3.1 LOCATION

The location of the mounting is not critical, but consideration must be given to provide adequate ventilation. The amplifier has a built-in fan that blows air out of the top. Therefore, care should be taken not to place papers, books, or other objects on top of the amplifier.

When the amplifier has been suitably mounted in a convenient position, connect a length of RG 58/U coaxial cable between the transceiver and the XCVR socket. Connect a 50 ohm antenna to the ANT socket (on the left, viewed from the back).

NOTE

The antenna system should be checked for VSWR of less than 2:1 before the Footwarmer is used. For best performance of your communication system, the VSWR should be as low as possible.

3.2 CONTROLS AND FUNCTIONS

- ON-OFF Switch..... Controls power to amplifier
- AM-FM & SSB Switch..... Adjusts delay constant of automatic antenna relay
- XMT-Standby Switch..... Controls the automatic antenna circuit
- Output Meter..... Visual indication of relative RF power output
- Tune-Operate Switch (Rear Panel)..... Provides for low power tune-up during initial tuning
- Drive Control (Rear Panel)..... Controls power output for optimum operation

The side control in the cover is used for tuning the amplifier. The amplifier is pretuned at 27.575 MHz and the tune control will allow tuning the amplifier to some other frequency.

NOTE

THE LOAD CONTROL IS NOT ACCESSIBLE FROM THE OUTSIDE. IT IS PRESET TO PROVIDE A CORRECT MATCH TO 50 OHM ANTENNA SYSTEM. THIS CONTROL SHOULD NOT BE ADJUSTED. IT IS FACTORY PRESET.

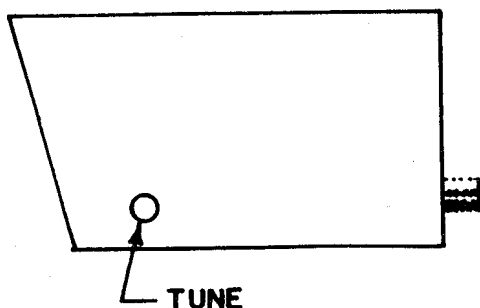

3.4 TUNING FOR AM USE: (Requires Wattmeter)

CAUTION

THIS SECTION SHOULD BE READ THOROUGHLY BEFORE OPERATING THE AMPLIFIER.

Place the function switch in the AM-FM position. Push the ON-OFF switch to ON. The red pilot light will come on. After allowing approximately 60 seconds for warm-up, push the XMT Standby switch to XMT. This will energize the automatic antenna relay control circuitry.

Set the Slide switch on the rear panel to the Tune position. Adjust the drive control for midway position. Apply 3.5 watts drive power by keying the exciter (transceiver) microphone and quickly adjust the tune control for maximum reading on the output meter. Remove the drive power after adjustment.

NOTE

Do not apply drive power for more than five seconds without adjusting the tune control or damage to the tubes can result.

Reapply drive power and adjust the drive control (on the rear panel) so that the amplifier produces approximately 100 watts output.

The input tuning coil is preset for the 26-35 MHz range. If operated outside this range it should be reset. To reset the input tuning coil (accessible from bottom), first place a VSWR bridge between the linear and the exciter. Apply drive power and reset the coil slug with a hex shaped non-metallic alignment tool for lowest SWR and maximum output in the "tune" position of the switch.

Set the Tune-Operate slide switch to the Operate position, reapply drive power and adjust the drive control for 150 watts output on the wattmeter. A readjustment of the input tuning coil may be necessary to produce minimum input VSWR.

NOTE

Always use a good peak reading watt meter such as the Hy-Gain 421A when trying to read Modulation peaks.

Readjust the tune control for maximum output and reset the drive control for 150 watts carrier output.

The amplifier is now adjusted to provide 150 watts carrier and 300 watts with full upward modulation. If the average output power decreases with modulation then either the transmitter (exciter) is incapable of upward modulation or the Amplifier has not been tuned up correctly and the above procedure should be re-checked. If this does not correct the situation, the drive control (on the rear panel) should be adjusted for a slightly lower power level necessary to produce upward modulation. It is far better to have reduced carrier power with upward modulation than a carrier power of a higher level with downward modulation. This will increase your communication range and provide a clearer signal with much less distortion.

The automatic antenna change-over operation in the amplifier is provided by a special transistorized input sensing circuit. Should you desire to hold the amplifier in a ready position, but not use it until needed, simply place the XMT-Standby switch in the Standby position. The sensing circuit will be disabled and the antenna connected to the exciter (transceiver) at all times.

3.5 TUNING FOR AM WITHOUT WATTMETER (26-35 MHz)

After proper installation and attachment of a nominal 50 ohm antenna, place the function switch in the AM-FM position and push the ON-OFF switch to ON.

The red pilot light will come on. After allowing approximately 60 seconds for warm-up, push the XMT Standby switch to XMT. This will energize the automatic antenna relay control circuitry.

Set the Slide switch on the rear panel to the Tune position. Adjust the drive control for midway position. Apply 3.5 watts drive power by keying the exciter (transceiver) microphone and quickly adjust the tune control for maximum reading on the output meter. Remove the drive power after adjustment.

NOTE

Do not apply drive power for more than five seconds without adjusting the tune control or damage to the tubes can result.

Reapply drive power and adjust the drive control for a meter reading of "6". Remove drive power.

Set the Tune-Operate switch to the Operate position, re-apply drive power and adjust the drive control for a meter reading of "7". Readjust the Tune Control for maximum reading on the meter. Reset the drive control for a meter reading of "7", if necessary.

The amplifier is now adjusted to provide approximately 150 watts carrier output with full upward modulation to 300 watts. If the meter reading decreases with modulation, either the exciter is incapable of upward modulation or the amplifier has not been tuned correctly and the procedure should be rechecked. If this does not correct the situation the drive control (on the rear panel) should be adjusted for a slightly lower power level necessary to produce upward modulation.

NOTE

Always use a good peak reading watt meter such as the Hy-Gain 421A when trying to read modulation peaks.

3.6 BEST AM OPERATION

For best AM operation the linear must be tuned according to above procedures. Many misconceptions regarding linear operation exist among linear users. Reviewing a few points regarding proper linear operation will help to provide better tune-up and communications for the user.

1. The linear amplifies the Radio Frequency (RF) signal.
2. If the output signal reproduced is identical to the input except stronger, the amplifier is said to be linear. If not, the amplifier is non-linear.
3. Non-linear operation produces spurious outputs and distortion of the signal.
4. All spurious signals use up power.
5. All power used to produce distortion and spurious signals is power not being used for communication.
6. The Amplifier provides a 300 watt RF envelope maximum power output.
7. Any attempt to operate AM at the 300 watt carrier level will produce downward modulation with distortion, and spurious signals.
8. Distortion and spurious signals (lost power) will occur in all linear amps if operation at maximum carrier power is attempted.
9. All linear amplifiers should be operated at about one half the maximum carrier output to allow for modulation expansion of the carrier.
10. Operation without leaving room for modulation expansion will not provide good communication. The carrier contributes nothing toward intelligibility, only good modulation can carry intelligence. Running higher carrier power and lower modulation is a detriment rather than an asset.

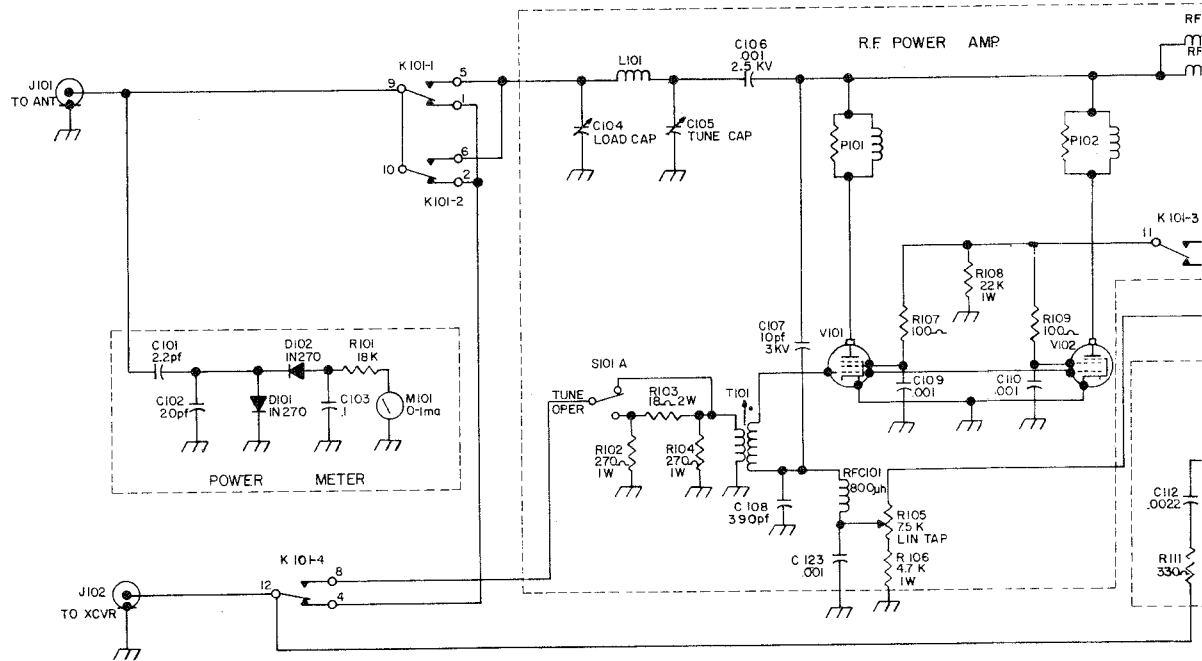

SECTION IV SERVICE INFORMATION

4.1 RETURNING EQUIPMENT FOR SERVICE

DO NOT ship equipment to the Manufacturer without prior authorization. We prefer to send special shipping labels which will avoid the delay of unexpected shipment.

If time is extremely important, wire or call for approval and we will rush labels to you. When a shipment is expected, even the time of sending the labels is less than that lost when an unexpected shipment is received.

It is VERY IMPORTANT that the shipment be well packed and fully insured. Damage claims must be settled between you and the carrier and will greatly delay any returns. Proper packing normally avoids this trouble.

ALL SHIPMENTS MUST BE SENT TO US PREPAID. We do not accept collect shipments. All returns should be made in our standard cartons only - so save your carton when unpacking the unit. When a shipment is returned it will be handled in one of three ways...

1 - Where all service is in warranty the shipment will be returned prepaid by a carrier of our choice.

2 - If there are any charges not covered by warranty we will hold the shipment and advise you of costs, which you can then send.

3 - Or, upon your written authorization, we will ship COD for any charges not covered by warranty, then the carrier will collect these charges and the transportation costs on arrival. Unclaimed or refused COD shipments will not be

reshipped until payment of service and transportation charges is received. Shipment will then be made collect for reshipment transportation charges. Unclaimed equipment automatically becomes the property of the Manufacturer 60 days after date of refusal or return and will be disposed of for payment of charge due.

NOTE

We WILL NOT ship by means of a carrier that will not fully insure the shipment. Some carriers have a \$200.00 limit. The exception to this is when there is no other means (APO-FPO-etc.) of shipment than parcel post, and then we will ship by this means with your written agreement that you assume any loss over that which the carrier will insure. COD shipments cannot be made to APO-FPO addresses.

4.2 REPLACEMENT PARTS ORDERING

All replacement parts orders must be prepaid or COD only.

Replacement part price quotes will be furnished on request for those who desire prepaid shipment or cannot accept COD shipments.

4.3 SHIPPING ADDRESS

All requests, inquiries, warranty claims or equipment returns should be made to:

Hy-Gain Electronics Corporation
8601 N.E. Highway 6
Lincoln, Nebraska 68507

Attn: Customer Service Manager

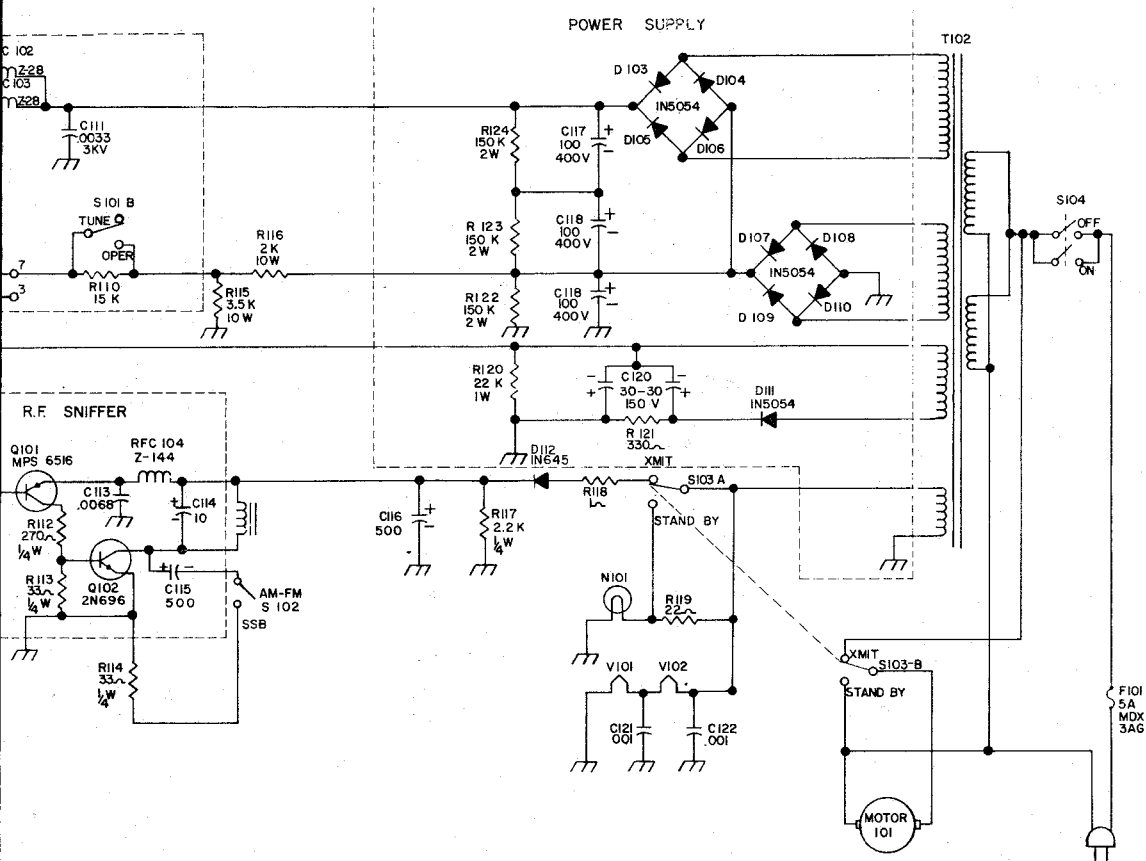

SECTION V WARRANTY

Hy-Gain Electronics Corporation warrants each new product manufactured to be free from defects in material and workmanship and agrees to remedy any such defect, or to furnish a new part, in exchange for any part of any unit which under normal installation, use, and service discloses such defect within ninety days from the date of purchase by original owner. The unit serial number must be registered by the original owner at the time of purchase to validate the warranty.

This warranty does not extend to any of our products which have been subjected to mis-use, neglect, accident, incorrect wiring not our own, improper installation or to use in violation of instructions furnished by us. Nor does it extend to units which have been repaired or altered outside of our factory nor to accessories used therewith not of our own manufacture, nor to any cases where the serial number has been removed, defaced, or changed.

Hy-Gain Electronics Corporation reserves the right to make

any changes deemed necessary or desirable without advance notice or incurring any obligation to make like changes in units previously manufactured or sold.

This warranty does not cover transportation or installation costs that may be incurred. Hy-Gain Electronics Corporation's sole liability is the remedy of any defect for ninety days. Hy-Gain Electronics Corporation is not responsible for personal injury or property damage resulting from improper or careless installation not intended by the manufacturer.

No person is authorized to assume for us any other liability in connection with the sale of our products.

All warranties are void and terminated one year after the last unit of its type and design has been manufactured by us.

PARTS LIST

Symbol	Description	Part No.	Symbol	Description	Part No.
C101	2.2 pf Disc Cap	721609	D101	1N270 Diode	765722
C102	20 pf Capacitor	725717	D102	1N270 Diode	765722
C103	.1 mfd	721574	D103	1N5054 Diode	765713
C104	Load Capacitor	720015	D104	" "	765713
C105	Tune Capacitor	721157	D105	" "	765713
C106	.001 mfd 2.5 KV	721660	D106	" "	765713
C107	10 pf 3 KV	721613	D107	" "	765713
C108	390 pf DSM	721700	D108	" "	765713
C109	.001 mfd	721158	D109	" "	765713
C110	.001 mfd	721158	D110	" "	765713
C111	.0033 3 KV	721159	D111	" "	765713
C112	.0022 mfd	721161	D112	1N645 Diode	761113
C113	.0068 mfd	721160			
C114	10 Ele Cap	721121	M101	0-1 MA Meter	795680
C115	500 Ele Cap	721120			
C116	500 Ele Cap	721120	MO101	110V Motor	740005
C117	100 mfd 400 VDC	721806			
C118	100 mfd 400 VDC	721806	K101	4 PDT Relay 12 VDC	730006
C119	100 mfd 400 VDC	721806			
C120	30-30 150 VDC Dual Cap	721796	J101	SO239 to Ant	657570
C121	.001 mfd	721158	J102	SO239 to Xcvr	657570
C122	.001 mfd	721158			
			T101	Input XFMR	720018
R101	18 K 1/2w 10%	721339	T102	Power XFMR	730211
R102	270 \sim 1W	720016			
R103	18 \sim 2 W	720017	L101	Pi-Network Coil	270014
R104	270 \sim 1W	720016			
R105	7.5 K 1/2 W Lin Tap	721451	RFC101	800 uh 2-P1	721902
R106	4.7 K 1 W	721367	RFC102	Z-28 Choke	721124
R107	100 \sim 1/2 W	720005	RFC103	Z-28 Choke	721124
R108	22 K 1 W	721373	RFC104	Z-144 Choke	728025
R109	100 \sim 1/2 W	720005			
R110	15 K 1/2 W	721340	S101	DPDT Slide Switch	700206
R111	330 \sim 1/2 W	721167	S102	SPST Rocker Switch	701147
R112	270 \sim 1/4 W	721112	S103	DPDT Rocker Switch	700010
R113	33 \sim 1/4 W	721103	S104	DPDT Rocker Switch	700010
R114	33 \sim 1/4 W	721103			
R115	3.5 K 10 W	721515	V101	Vacuum Tube	760004
R116	2 K 10 W	721527	V102	Vacuum Tube	760004
R117	2.2 K 1/4 W	721116			
R118	1 \sim 1/2 W	720020	Q101	MPS6516	761115
R119	22 \sim 1/2 W	725639	Q102	2N 696	761114
R120	22 K 1 W	721373			
R121	330 \sim 1/2 W	721167	N101	12 V Lamp	710007
R122	150 K 2 W	721404			
R123	150 K 2 W	721404	F101	5 A MDX 3AG	710003
R124	150 K 2 W	721404			
P101	Parasitic Choke	721950			
P102	Parasitic Choke	721950			