



SVETLANA TECHNICAL DATA

4CPW10,000R Pulse Modulator Tetrode

The Svetlana™ 4CPW10,000R is a liquid cooled ceramic metal tetrode designed for pulse modulator or regulator use with HF or microwave high power electron tubes. The Svetlana 4CPW10,000R has a directly-heated thoriated tungsten mesh filament for mechanical ruggedness. This modern mesh filament design is superior to the old hairpin design of the 1950's. The high voltage standoff of the Svetlana 4CPW10,000R is 25 KVDC and the peak current rating is 24 amperes.

The Svetlana 4CPW10,000R is manufactured in the Svetlana factory in St. Petersburg, Russia, and is designed to be a direct replacement for the 4CPW10,000 or Y442 manufactured in the United States, England and elsewhere.

Characteristics

Electrical

Filament:	<i>Thoriated tungsten mesh</i>	
Voltage	<i>7.5±0.37</i>	<i>V</i>
Current, at 7.5 Volts	<i>75</i>	<i>A</i>
Amplification factor (average)		
Grid to screen	<i>4.5</i>	
Direct interelectrode capacitances (grounded filament):		
<i>C_{in}</i>	<i>115</i>	<i>pF</i>
<i>C_{out}</i>	<i>20</i>	<i>pF</i>
<i>C_{gp}</i>	<i>0.7</i>	<i>pF</i>

Mechanical

Maximum overall dimensions:		
Length	<i>29.06 cm (11.44 in)</i>	
Diameter	<i>11.83 cm(4.66 in)</i>	
Net Weight	<i>3.4 kg (7.5 lb)</i>	
Operating Position	<i>Axis vertical, base up or down</i>	
Maximum operating temperature, ceramic/metal or anode core	<i>250° C</i>	
Cooling	<i>Water and forced air</i>	
Base Coaxial, designed for use with Svetlana SK300A		

Pulse Modulator or Switch Tube Service

Absolute Maximum Ratings

Plate voltage	<i>25</i>	<i>kV</i>
Screen voltage	<i>2.0</i>	<i>kV</i>
Grid voltage	<i>2.0</i>	<i>kV</i>
Peak plate current (average during pulse)	<i>24</i>	<i>A</i>
Plate dissipation	<i>10</i>	<i>kW</i>
Screen dissipation	<i>250</i>	<i>W</i>
Grid dissipation	<i>75</i>	<i>W</i>

Svetlana Outline drawing

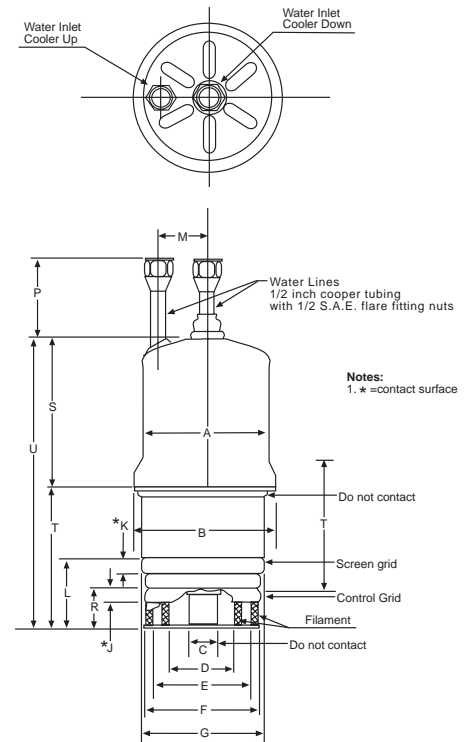

Dimensional Data

	Millimeters		Inches	
	Min.	Max.	Min.	Max.
A	103.8	105.6	4.094	4.156
B	116.6	118.3	4.594	4.656
C	15.2	19.3	.600	.760
D	48.1	49.2	1.896	1.936
E	79.5	80.6	3.133	3.173
F	96.3	97.4	3.792	3.832
G	101.0	102.2	3.980	4.020
J	4.7	—	.188	—
K	4.7	—	.188	—
L	44.8	46.4	1.764	1.826
M	38.1	44.5	1.500	1.750
P	58.7	71.5	2.312	2.812
R	25.0	26.7	.986	1.050
S	121.4	127.7	4.780	5.025
T	85.1	92.7	3.350	3.650
U	206.3	219.1	8.125	8.625



Svetlana 4CPW10,000R Pulse Modulator Tetrode

Typical Operation

DC plate voltage	20.0	kV
DC screen voltage	1250	V
DC grid voltage	-700	V
Peak plate current	20.0	A
Peak screen current*(average during pulse)	1.4	A
Peak grid current*(average during pulse)	0.26	A
Peak rf grid voltage*	140	V
Peak output voltage	18.5	kV
Peak input power	400	kW
Peak output power	370	kW

Minimum Cooling Requirements

Cooling of the base may be accomplished by directing approximately 30 CFM of air through the Svetlana SK300A air system socket and over the filament and grid seals. Anode cooling is accomplished by circulating water through the integral water jacket as listed in the table below for several dissipation levels.

Minimum Cooling Water Requirement

Plate Dissipation (kw)	Quantity (gpm)	Pressure Drop (psi)
6	4.0	2.2
8	5.1	3.1
10	6.3	4.3

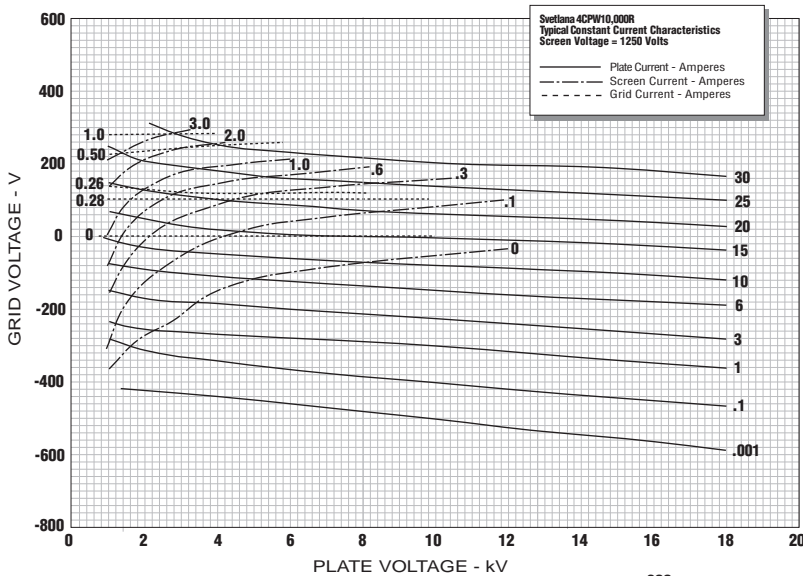

NOTES:

1. Since power dissipated by the filaments represented about 560 watts and grid plus screen dissipation can represent another 325 watts, an extra 900 watts has been added to plate dissipation in preparing this tabulation.
2. Maximum outlet-water temperature must never exceed 70°C and inlet-water pressure should be limited to 50 psi.

