

# Svetlana 3CX6000A7 / YU148 High-Mu Power Triode



**T**he Svetlana™ 3CX6000A7 / YU148 is a high-performance ceramic/metal power triode designed for use in zero-bias, RF amplifier service, and modulator service. A modern mesh filament is used, replacing the old-fashioned hairpin construction. The improved mesh filament design ensures better mechanical rigidity and long lasting concentricity of the filament, providing enhanced linearity, less noise, reduced warm-up variation and longer life. The low-inductance, mesh-filament basket also forms a natural extension of the cylindrical stem geometry into the active area, giving superior VHF performance.

The Svetlana 3CX6000A7 / YU148 is manufactured in the Svetlana Electron Devices complex in St. Petersburg, Russia. Svetlana has achieved the improved performance described above with exact replacement compatibility with the 3CX6000A7 / YU148 manufactured in the United States.



# Svetlana 3CX6000A7 / YU148

## General Characteristics

### Electrical

Filament	Thoriated-tungsten mesh
Voltage	7.0 ±0.35 V
Current @ 7.0V	78 A
Amplification factor (average)	200
Direct interelectrode capacitances (grounded grid)	
Input	42 pF
Output	24.5 pF
Feedback	0.28 pF

### Mechanical

Cooling	Forced air
Base	Coaxial
Socketing	Via spring collets
Operating position	Vertical, Base up or down
Maximum operating temperature	250° C
Maximum dimensions:	
Length	228.60 mm (9.000 in.)
Diameter	155.58 mm (6.125 in.)
Net weight	3.64 kg (8.01 lb)

### Cathode-Driven Class C RF Amplifier, CW or FM

Maximum Ratings			
DC Plate voltage	7000	V	
DC Plate current	3.5	A	
Plate dissipation	6000	W	
Grid dissipation	225	W	

### Typical operation

(Frequencies to 110MHz)

Plate voltage	4800	5700	6000	V
Grid voltage	0	0	-100	V
Plate current	2.3	2.5	2.56	A
Grid current*	0.32	0.33	0.48	A
Peak RF cathode voltage*	215	224	340	V
Calculated driving power*	500	600	800	W
Plate dissipation	3200	4100	3900	W
Useful output power	8000	10000	12000	W

\*Approximate values



# High-Mu Power Triode

Svetlana 3CX6000A7/YU148 Outline Drawing

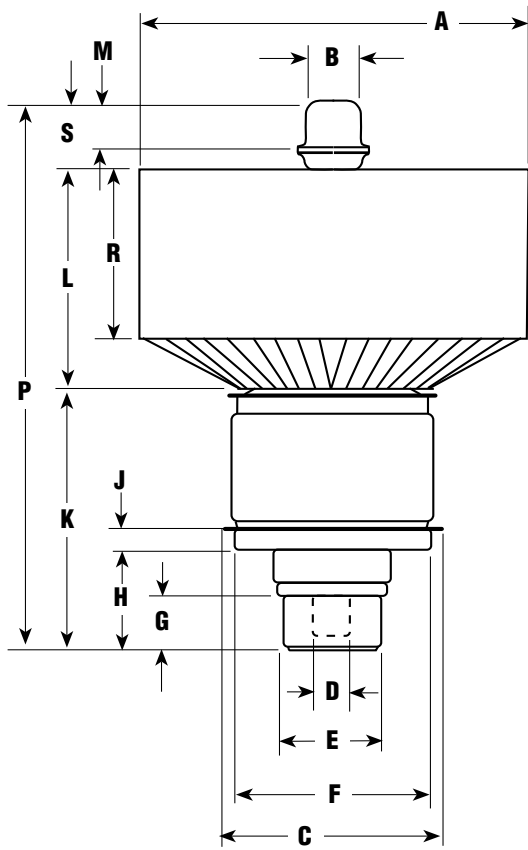

Dimensional Data				
Dim.	Millimeters		Inches	
	Min.	Max.	Min.	Max.
A	152.4	155.58	6.00	6.125
B	19.8	21.4	0.78	0.843
C	—	92.1	—	3.625
D	15.6	16.1	0.614	0.635
E	37.6	38.4	1.488	1.512
F	75.9	76.4	2.988	3.010
G	20.6	23.8	0.811	0.937
H	34.9	41.3	1.374	1.626
J	9.5	11.1	0.374	0.437
K	96.4	107.9	3.874	4.250
L	—	84.5	—	3.327
M	17.5	20.6	0.688	0.812
P	203.2	226.6	8.000	9.000
R	—	65.1	—	2.563
S	25.4	28.6	1.000	1.126

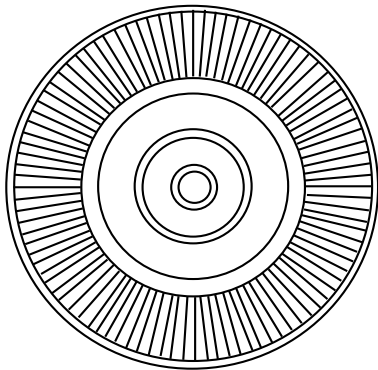

# Svetlana 3CX6000A7 / YU148

## Electrical Application

**Filament Operation** The rated filament voltage for the 3CX6000A7/YU148 is 7.00 volts. Filament voltage, as measured at the filament collets, should be maintained within 5% of this value to obtain maximum tube life.

**Input Circuit** A resonant tank circuit is recommended for grounded-grid operation. In a single-ended circuit the loaded “Q” should be at least 5. This technique increases linearity and output power.

## Mechanical Application

**Mounting** The 3CX6000A7/YU148 must be mounted with its axis vertical. The base of the tube may be up or down.

**Filament Connections** The Svetlana 3CX6000A7/YU148 filament connections require spring collets designed for a contact surface temperature of 250°C and with adequate symmetrical contact surface area for the filament and RF current.

**Cooling** Sufficient forced-air circulation must be provided to keep the temperature of the anode core and the temperatures of the ceramic/metal seals below 250°C. Airflow requirements to maintain these temperatures below 225°C with an inlet-air temperature of 50°C are tabulated. At frequencies above 40 MHz or at higher inlet-air temperatures, more airflow will be required.

Base-to-Anode Air Flow		
*	Sea Level	
Anode Dissipation Watts	Air Flow CFM	Pressure Drop Inches of Water
5000	142	0.22
6000	205	0.40

Anode-to-Base Air Flow <sup>1</sup>		
*	Sea Level	
Anode Dissipation Watts	Air Flow CFM	Pressure Drop Inches of Water
4500	250	1.0
5000	300	1.2

\* Because the power dissipated by the filament represents about 546 watts and because grid dissipation can, under some conditions, represent another 225 watts, allowance has been made in preparing this tabulation for an additional 771 watts.

<sup>1</sup> When air is supplied in the anode-to-base direction, a minimum of 5 cfm must be directed into the filament-stem structure between the inner and outer filament terminals to maintain the base seals below 250° C. A separate air system is not required with base-to-anode airflow.



# High-Mu Power Triode

