

Svetlana 3CX15,000A3 Medium-Mu Power Triode



The Svetlana™ 3CX15,000A3 is a high-performance ceramic/metal power triode designed for use in industrial heating, communications and AM broadcast applications. A modern mesh filament is used, replacing the old-fashioned hairpin construction. The improved mesh filament design ensures better mechanical rigidity and long lasting concentricity of the filament, providing enhanced linearity, less noise, reduced warm-up variation and longer life. The low-inductance, mesh-filament basket also forms a natural extension of the cylindrical stem geometry into the active area, giving superior VHF performance.

The Svetlana 3CX15,000A3 is manufactured in the Svetlana Electron Devices complex in St. Petersburg, Russia. Svetlana has achieved the improved performance described above with exact replacement compatibility with the 3CX15,000A3 manufactured in the United States.



Svetlana 3CX15,000A3

General Characteristics

Electrical

Filament	Thoriated-tungsten mesh
Voltage	6.3 ±0.3 V
Current @ 7.50V	160 A
Amplification factor (average)	20
Direct interelectrode capacitances (grounded grid):	
Input	55.0 pF
Output	34.0 pF
Feedback	1.4 pF
Direct interelectrode capacitances (grounded filament):	
Input	55.0 pF
Output	1.4 pF
Feedback	34.0 pF
Maximum frequency for full ratings (CW)	100 MHz

Mechanical

Cooling	Forced air
Base	Coaxial
Socketing	Svetlana SK1300, 1320 or equiv.
Air chimney	Eimac SK1306 or equiv.
Operating position	Vertical, Base up or down
Maximum operating temperature	250° C
Maximum dimensions:	
Length	222.25 mm (8.75 in.)
Diameter	179.07 mm (7.05 in.)
Net weight	5.45 kg (12 lb)

Cathode-Driven Radio Frequency Linear Amplifier, Class AB₂

Maximum Ratings	
DC plate voltage	8,000 V
DC plate current	6.0 A
Plate dissipation	15 kW
Grid dissipation	500 W

Typical operation

DC plate voltage	7000 V
Zero-signal DC plate current	1.5 A
Single-tone DC plate current	4.8 A
Zero-signal DC grid voltage*	-270 V
Max DC grid current	0.4 A
Peak RF grid voltage	540 V
Peak driving power	215 W
Single-tone plate output power	23 kW
Resonant load impedance	730ohms

*Approximate values

Medium-Mu Power Triode

RF Industrial Oscillator or Amplifier, Class C

Maximum ratings (per tube)

DC plate voltage	8000	V
DC plate current	6.0	A
Plate dissipation	15	kW
Grid dissipation	500	W

Typical operation

DC plate voltage	7000	V
DC grid voltage	-600	V
Maximum-signal DC plate current	6.0	A
Maximum-signal DC grid current	0.66	A
Peak AF grid voltage	1040	V
Driving power	660	W
Plate input power	42	kW
Plate output power	30	kW
Plate dissipation	12	kW
Resonant load impedance	600	ohms

3CX15,000A3 Outline Drawing

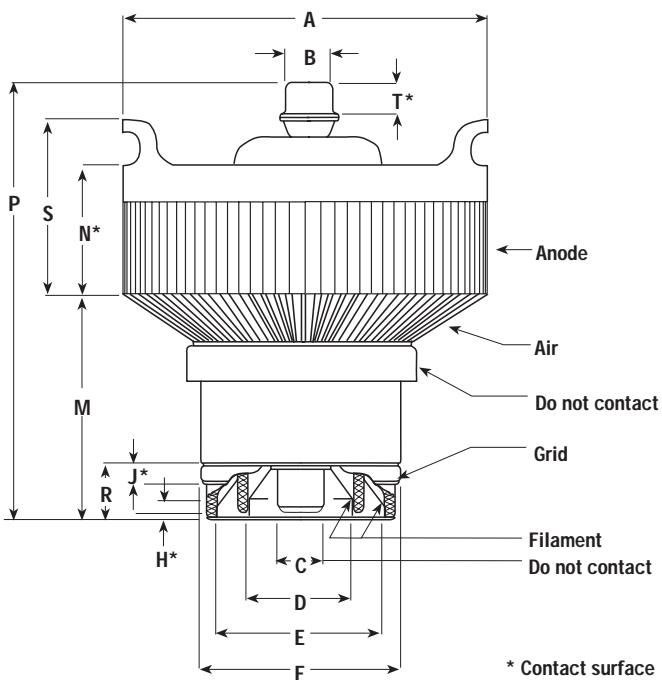

Dimensional Data

Dim.	Millimeters		Inches	
	Min.	Max.	Min.	Max.
A	175.97	179.07	6.928	7.050
B	21.72	22.73	0.855	0.895
C	18.29	19.30	0.720	0.760
D	48.16	49.17	1.896	1.936
E	79.58	80.59	3.133	3.173
F	96.32	97.33	3.792	3.832
H	4.78	—	0.188	—
J	4.78	—	0.188	—
M	100.33	109.22	3.950	4.300
N	61.26	70.82	2.412	2.788
P	209.55	222.25	8.250	8.750
R	25.04	26.67	0.986	1.050
S	86.66	96.22	3.412	3.788
T	9.53	—	0.375	—

Svetlana 3CX15,000A3

Electrical Application

Filament Operation The rated filament voltage for the 3CX15,000A3 is 6.30 volts. Filament voltage, as measured at the socket, should be maintained within 5% of this value to obtain maximum tube life.

Grid Operation A recommended maximum grid current is 1.0 Adc. This value should not be exceeded for more than very short periods such as during tuning. Over-current protection in the grid circuit should be provided. Ordinarily it will not be necessary to operate with more than 0.4 to 0.6 amperes grid current to obtain reasonable efficiency. In industrial heating service with varying loads, grid current should be monitored continuously with a DC current meter. The absolute maximum grid dissipation rating is 500 watts.

Plate Operation Absolute maximum plate voltage rating of 8 kV and maximum plate current of 6.0 amperes should not be applied simultaneously as rated plate dissipation may be exceeded. Plate overcurrent protection should be provided to remove plate voltage quickly in the event of an over-load or an arc-over at the load. In addition, current limiting power supply resistors should be used. These precautions are especially important in industrial service having wide variations in plate current loading.

Spark gaps from plate to ground should be used to prevent transient voltages from flashing across the tube envelope during any fault conditions.

High Frequency Operation The 3CX15,000A3 is usable to 140 MHz. At this frequency, absolute maximum plate voltage must be reduced to 7000 Vdc Class A, B, or C service. The Svetlana 3CX15,000A3 mesh filament construction gives enhanced performance at VHF frequencies.

Mechanical Application

Mounting The 3CX15,000A3 must be mounted with its axis vertical. The base of the tube may be up or down.

Cooling Sufficient forced-air circulation must be provided to keep the temperature of the anode core and the temperatures of the ceramic/metal seals below 250°C. Airflow requirements to maintain these temperatures below 225°C with an inlet-air temperature of 40°C are tabulated for base to anode direction

*	Sea Level		10,000 Feet	
	Air Flow CFM	Pressure Drop Inches of Water	Air Flow CFM	Pressure Drop Inches of Water
Anode Dissipation Watts				
5000	85	0.2	160	0.36
10,000	360	2.0	390	1.40
15,000	970	10.5	650	2.90

* An additional 1500 watts has been included in preparing this tabulation to compensate for grid and filament power.



