

SVETLANA TECHNICAL DATA

3CW20,000H3

Medium-Mu Industrial Power Triode



The Svetlana™ 3CW20,000H3 is a high-performance ceramic/metal power triode designed for use in oscillator, amplifier, or modulator service. The ceramic is glazed to facilitate cleaning when used in an industrial environment. A modern mesh filament is used, replacing the old-fashioned hairpin construction. The improved mesh filament design ensures better mechanical rigidity and long lasting concentricity of the filament, contributing to longer life. The mesh filament also provides improved RF efficiency at VHF operation. Flexible leads connect to the filament terminals and flanges are connected to the grid and plate. The flanges provide a convenient way to mount the tube.

The Svetlana 3CW20,000H3 is manufactured in the Svetlana Electron Devices complex in St. Petersburg, Russia. Svetlana has achieved the improved performance described above with exact replacement compatibility with the 3CW20,000H3 manufactured in the United States.

Characteristics

Electrical	
Filament:	Thoriated-tungsten mesh
Voltage	7.5 ± 0.37 V
Current @ 7.5V	100 ± 10.0 A
Amplification factor (average)	20
Direct interelectrode capacitances, with filament grounded:	
Input	53.0 pF
Output	1.3 pF
Feedback	34 pF
Maximum frequency for full ratings (CW)	90 MHz

Mechanical	
Cooling	Water and forced air
Base	Flying leads/flange
Socketing	None. Mounting flanges
Operating position	Vertical, base up or down
Maximum operating temperature	250° C
Maximum dimensions:	
Length	26.54 cm (10.45 in.)
Diameter	17.15 cm (6.75 in.)
Net weight	5.46 kg (12 lb.)

RF Power Amplifier or Oscillator, Class C, (Filtered DC Plate Power Supply)		
Maximum Ratings		
DC plate voltage	12,000	V
DC plate current	4.0	A
Plate dissipation	20	kW
Grid dissipation	250	W
DC grid voltage	-1000	V
DC grid current	0.6	A
Plate input power	40	kW

Svetlana Outline drawing

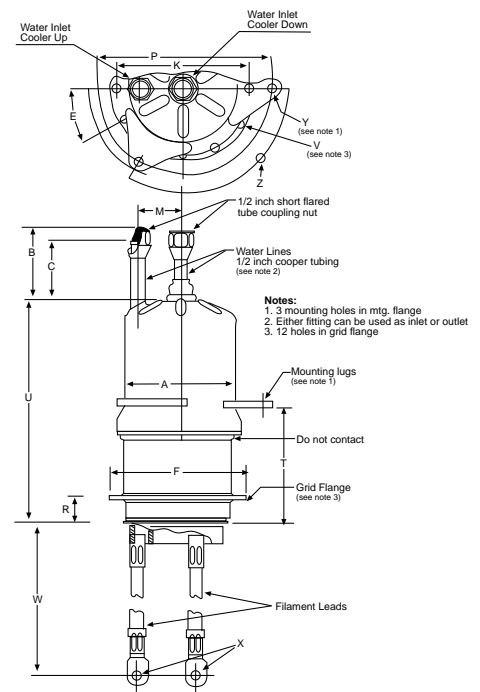

	Millimeters			Inches		
	Min.	Max.	Nom.	Min.	Max.	Nom.
A	103.99	105.56	—	4.094	4.156	—
B	56.72	71.42	—	2.312	2.812	—
C	49.20	55.55	—	1.937	2.187	—
E	—	—	30°	—	—	30°
F	127.76	129.29	—	5.030	5.090	—
K	112.40	112.90	—	4.425	4.445	—
M	38.10	44.45	—	1.500	1.750	—
P	151.31	153.04	—	5.957	6.025	—
R	17.78	21.84	—	.700	.860	—
T	110.49	113.03	—	4.350	4.450	—
U	200.74	213.44	—	7.903	8.403	—
V	—	—	6.35	—	—	.250
W	215.90	228.60	—	8.500	9.000	—
X	—	—	9.91	—	—	.390
Y	—	—	6.73	—	—	.265
Z	—	—	120°	—	—	120°



Svetlana 3CW20,000H3 Medium-Mu Industrial Power Triode



Typical Operation (under load)

(Frequencies to 30MHz)

DC plate voltage	7,000	10,000	V
DC plate current	4.0	4.0	A
DC grid voltage	-670	-800	V
DC grid current	275	315	mA
Peak RF grid voltage	340	340	V
Driving power	260	350	W
Grid dissipation	78	46	W
Plate input power	28,000	40,000	W
Plate dissipation	9,000	12,000	W
Plate output power	19,000	28,000	W
Approximate load impedance	720	1270	Ohms

Minimum Water Cooling Requirements*

Anode Dissipation Watts	Water Flow GPM	Pressure Drop PSI
10,000	6.3	4.9
15,000	9.0	9.2
20,000	12.0	15.0

* A minimum of 40 CFM of air must be directed onto the center filament contact ring.

