

# Svetlana 3CW20,000A7 High-Mu Power Triode



**T**he Svetlana™ 3CW20,000A7 is a high-performance ceramic/metal, water cooled power triode designed for use in zero-bias, class B RF or audio amplifiers. A modern mesh filament is used, replacing the old-fashioned hairpin construction. The improved mesh filament design ensures better mechanical rigidity and long lasting concentricity of the filament, providing enhanced linearity, less noise, reduced warm-up variation and longer life. The low-inductance, mesh-filament basket also forms a natural extension of the cylindrical stem geometry into the active area, giving superior VHF performance to 200MHz.

The Svetlana 3CW20,000A7 is manufactured in the Svetlana Electron Devices complex in St. Petersburg, Russia. Svetlana has achieved the improved performance described above with exact replacement compatibility with the 3CW20,000A7 manufactured in the United States.

## Svetlana 3CW20,000A7 Outline drawing

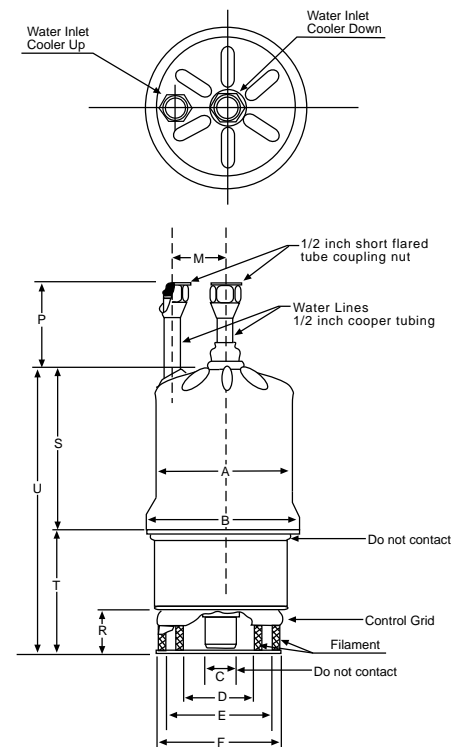

### General Characteristics

#### Electrical

Filament	Thoriated-tungsten mesh
Voltage	7.50 ±0.37V
Current @ 7.50V	100A
Amplification factor (average)	200
Direct interelectrode capacitances (grounded grid):	
Input	59.0pF
Output	36.0pF
Feedback	0.2pF
Direct interelectrode capacitances (grounded filament):	
Input	59.0pF
Output	0.2pF
Feedback	36.0pF
Maximum frequency for full ratings (CW)	200 MHz

#### Mechanical

Cooling	Water and forced air
Base	Coaxial
Socketing	Svetlana SK1300, SK1320 or equiv.
Operating position	Vertical, Base up or down
Maximum operating temperature	250° C
Maximum dimensions:	
Length	284.99 mm (11.22 in.)
Diameter	119.40 mm (4.7in.)
Net weight	5.45 kg (12 lb)

### Dimensional Data

	Millimeters		Inches	
	Min.	Max.	Min.	Max.
A	103.99	105.56	4.094	4.156
B	116.69	119.40	4.594	4.700
C	18.29	19.30	0.720	0.760
D	48.16	49.17	1.896	1.936
E	79.58	80.59	3.133	3.173
F	96.32	97.33	3.792	3.832
N	49.20	55.55	1.937	2.187
P	58.73	71.43	2.312	2.812
R	25.04	26.67	0.986	1.050
S	121.41	127.64	4.780	5.025
T	79.45	37.07	3.128	3.428
U	200.74	213.44	7.903	8.403



# Svetlana 3CW20,000A7 High-Mu Power Triode



## Cathode-Driven Radio Frequency Linear Amplifier, Class B

Maximum Ratings			
DC plate voltage	7,000		V
DC plate current	5.0		A
Plate dissipation	20		kW
Grid dissipation	500		W
Typical Operation			
DC plate voltage	7000	7000	V
Zero-signal DC plate current*	0.60	0.60	A
Single-tone DC plate current	3.72	5.00	A
Grid bias	0	0	V
Single-tone DC grid current*	0.71	1.00	A
Peak driving power	885	1540	W
Single-tone plate output power	17.7	24.2	kW
Resonant load impedance	1020	745	Ohms
Driving impedance	35	32	Ohms

\*Approximate values

## Cathode-Driven Class C RF Amplifier, CW or FM

Maximum Ratings			
DC plate voltage	7,000		V
DC plate current	4.0		A
Plate dissipation	20		kW
Grid dissipation	500		W
Typical Operation			
DC plate voltage	5000	7000	V
DC grid voltage	-210	-210	V
DC plate current	4.0	4.0	A
DC grid current*	0.84	0.775	A
Peak RF grid voltage*	510	555	V
Driving power	420	530	W
Plate output power	14.0	21.3	kW

## Audio Frequency Amplifier or Modulator, Class B Grid Driven

Maximum ratings (per tube)			
DC plate voltage	7000		V
DC plate current	5.0		A
Plate dissipation	12		kW
Grid dissipation	500		W

## Typical Operation (two tubes sinusoidal waveform)

DC plate voltage	5000	7000	Vdc
DC grid voltage	0	0	V
Zero-signal DC plate current*	1.2	1.2	A
Maximum-signal DC plate current	10	10	A
Maximum-signal DC grid current*	1.2	2.1	A
Peak AF grid voltage**	240	310	V
Peak driving power	290	560	W
Plate output power	31.0	47.7	kW
Load resistance (plate-to-plate)	1030	1520	Ohms

\*Approximate values \*\*Per tube

