

8792/V1 Power Tube

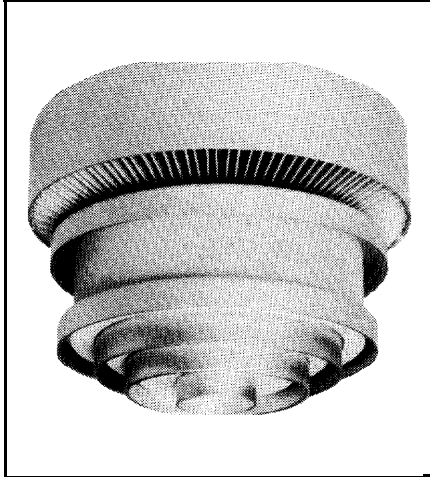

VHF-TV Amplifier Tube

- CERMOLOX®
- Full Input to 400 MHz
- Sturdy, Reliable
- Matrix Oxide Cathode
- 1350 Peak Sync Output in VHF-TV Service

The BURLE 8792/V1 is designed specifically to meet the stringent requirements of modern VHF-TV equipments.

Its high gain, CERMOLOX tube construction and full input rating to 400 MHz also make it ideally suited for high frequency applications such as VHF-TV grid-modulated service and VHF or UHF Class B linear service where it will deliver 1350 watts peak sync or 300 watts carrier output respectively.

The low inductance, coaxial construction enables the use of simple, economical circuit techniques in all HF, VHF and UHF applications.

Its matrix oxide cathode enhances system reliability while the efficient, forced-air cooled radiator reduces system air requirements and permits more reliable, lower temperature operation.

This bulletin gives application information unique to the BURLE 8792/V1. General information, covering the installation and operation of this tube type, is given in the "Application Guide for BURLE Power Tubes," TP-105. Close attention to the instructions contained therein will assure longer tube life, safer operation, less equipment downtime, and fewer tube handling accidents.

General Data

Electrical

Heater-Cathode:

Type	Unipotential, Oxide Coated, Matrix Type
Voltage¹ (AC or DC)	5.5 typ. V 5.8 max. V
Current (@ 5.5 V)	17.3 A
Minimum heating time	180 s

Mu Factor² (Grid No.1 to grid No.2) 6.5

Direct Interelectrode Capacitances:

Grid No.1 to plate ³	0.2 max. pF
Grid No.1 to cathode-heater	38 pF
Plate to cathode-heater ³	0.2 max. pF
Grid No.1 to grid No.2	52 pF
Grid No.2 to plate	16 pF
Grid No.2 to cathode-heater ³	1.4 pF

Mechanical

Operating Position	Any
Maximum Length	84.8 mm (3.34 in)
Greatest Diameter	95.3 mm (3.75 in)
Terminal Connection	See Dimensional Outline
Socket	See Page 2
Radiator	Integral Part of Tube
Weight (Approx.)	0.9 kg (2 lbs)

Thermal

Seal Temperature⁴	250 max. °C (Plate, grid No.1, grid, No.2 cathode-heater and heater)
Plate Core Temperature ⁴	250 max. °C

Linear RF Power Amplifier

VHF Television Service, Class AB

Synchronizing-level conditions per tube unless otherwise specified.

Maximum CCS Ratings, Absolute-Maximum Values

DC Plate Voltage	3500	V
DC Grid-No.2 Voltage	1000	V
DC Plate Current	1.25	A
Plate Dissipation	1500	W
Grid-No.2 Input	50	W

Typical Operation

In a cathode-drive circuit with video RF drive at 200 MHz and a 1.0 dB bandwidth of 6.5 MHz min.

DC Plate Voltage	2500	V
DC Grid-No.2 Voltage	600	V
DC Grid-No. 1 Voltage	-55	V
DC Plate Current:		
Zero signal	0.5	A
Synchronizing level	1.25	A
Pedestal level	0.9	A
DC Grid-No.2 Current:		
Synchronizing level	50	mA
DC Grid-No.1 Current:		
Synchronizing level	0	mA
Drive Power Output:		
Synchronizing level	63	W
Pedestal level	38	W
Useful Power Output:		
Synchronizing level	1350	W
Pedestal level	750	W

Linear RF Power Amplifier'

Class AB or Class B Telephony

Carrier conditions for use with a maximum modulation factor of 1.0.

Maximum CCS Ratings, Absolute-Maximum Values

DC Plate Voltage'	3500	V
DC Grid-No.1 Voltage'	1000	V
DC Plate Current	700	mA
Grid-No.2 Input	50	W
Plate Dissipation	1500	W

Calculated CCS Operation as a Class AB₁ Amplifier

In a cathode drive circuit at 400 MHz with an output circuit bandwidth of 3.5 MHz⁵.

DC Plate Voltage	2600	V
DC Grid-No.2 Voltage'	500	V
DC Grid-No.1 Voltage ⁶	-65	V
DC Plate Current	550	mA
DC Grid-No.1 Current	0	A
DC Grid-No.2 Current	-10	mA
Driver Power (Approx.)	25	W
Output Circuit Eff. (Approx.)	90	%
Useful Power Output	300	W

1. See TP-105.
2. For: Plate Voltage = 2500 V.
Grid-No.2 Voltage = 600 V.
Plate Current = 600 mA.
3. With special shield adapter.
4. See Dimensional Outline for temperature measurement points.
5. Computed between half-power points using two times tube capacity.
6. Adjust for zero-signal DC plate current of 0.2 A.

Sockets may be obtained from:

Erie Technological Products, Inc.
644 West 12th Street
Erie, PA 16512

Jettron Products, Inc.
65 Route 10, P.O. Box 337
East Hanover, NJ 07938

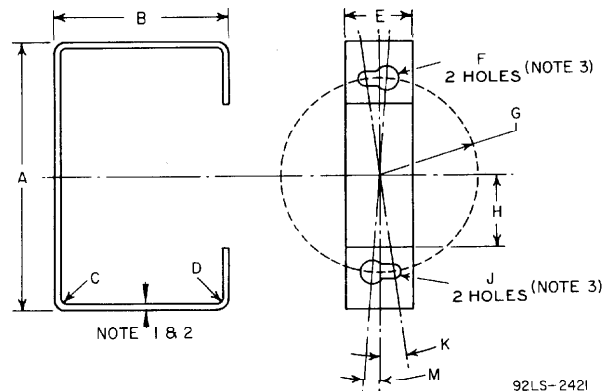

Figure 1 - Tube Extractor - Suggested Design

Dim.	Value	
A	71.0	(2.8)
B	46.0	(1.8)
C	1.5	(0.06) Radius
D	1.5	(0.06) Radius
E	18.0	(0.7)
F	6.350 ± 0.127	(0.250 ± 0.005) Dia.
G	25.781 ± 0.127	(1.015 ± 0.005) Radius
H	19.0	(0.75)
J	3.556 ± 0.127	(0.140 ± 0.005) Dia.
K	0.145	(8.3°) Radians
M	0.078	(4.5°) Radians

Note 1 - Material 1/16" thick cold rolled steel.

Note 2 - Round all edges.

Note 3 - Slot between holes.

Warning - Personal Safety Hazards

Electrical Shock - Operating voltages applied to this device present a shock hazard.

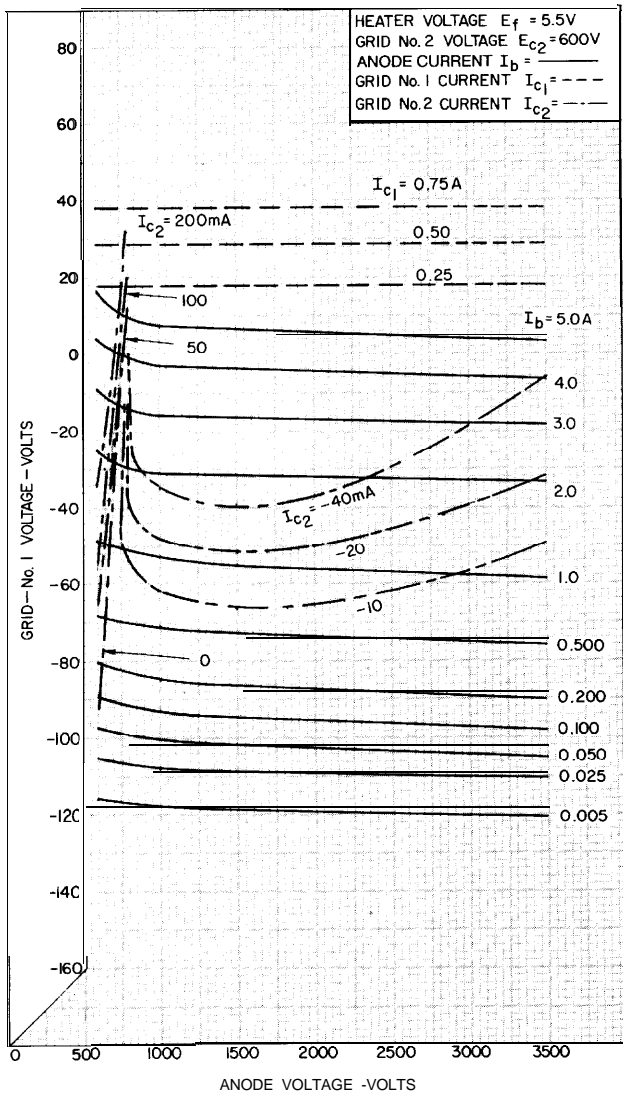

92LM-2437

Figure 2 - Typical Constant Current Characteristics
 ($E_{c2} = 600 V$)

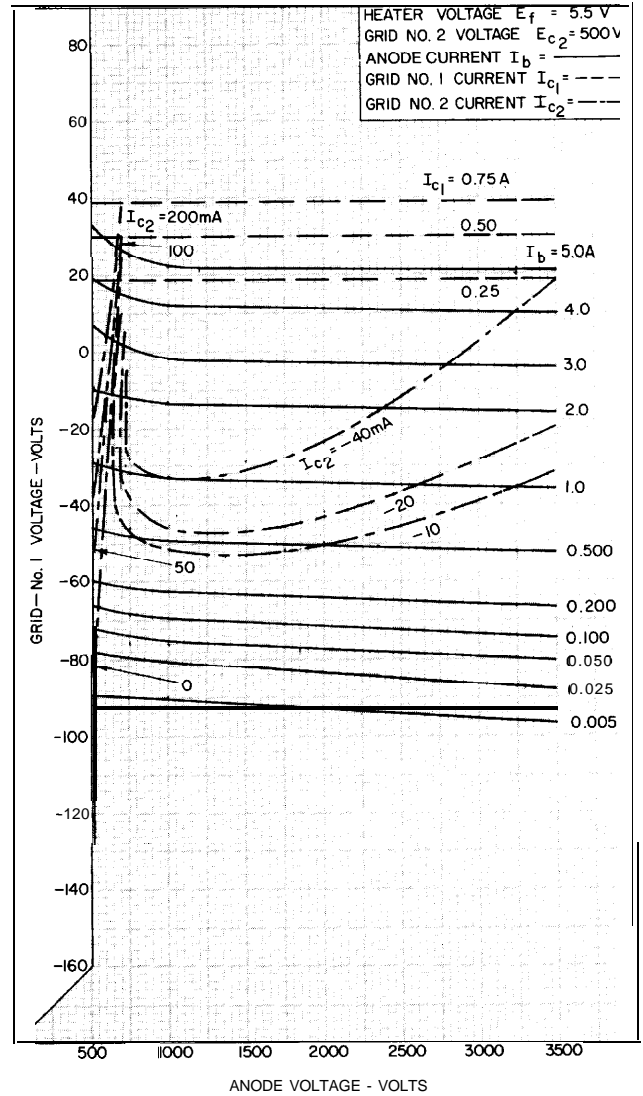

92LM-2432

Figure 3 - Typical Constant Current Characteristics
 ($E_{c2} = 500 V$)

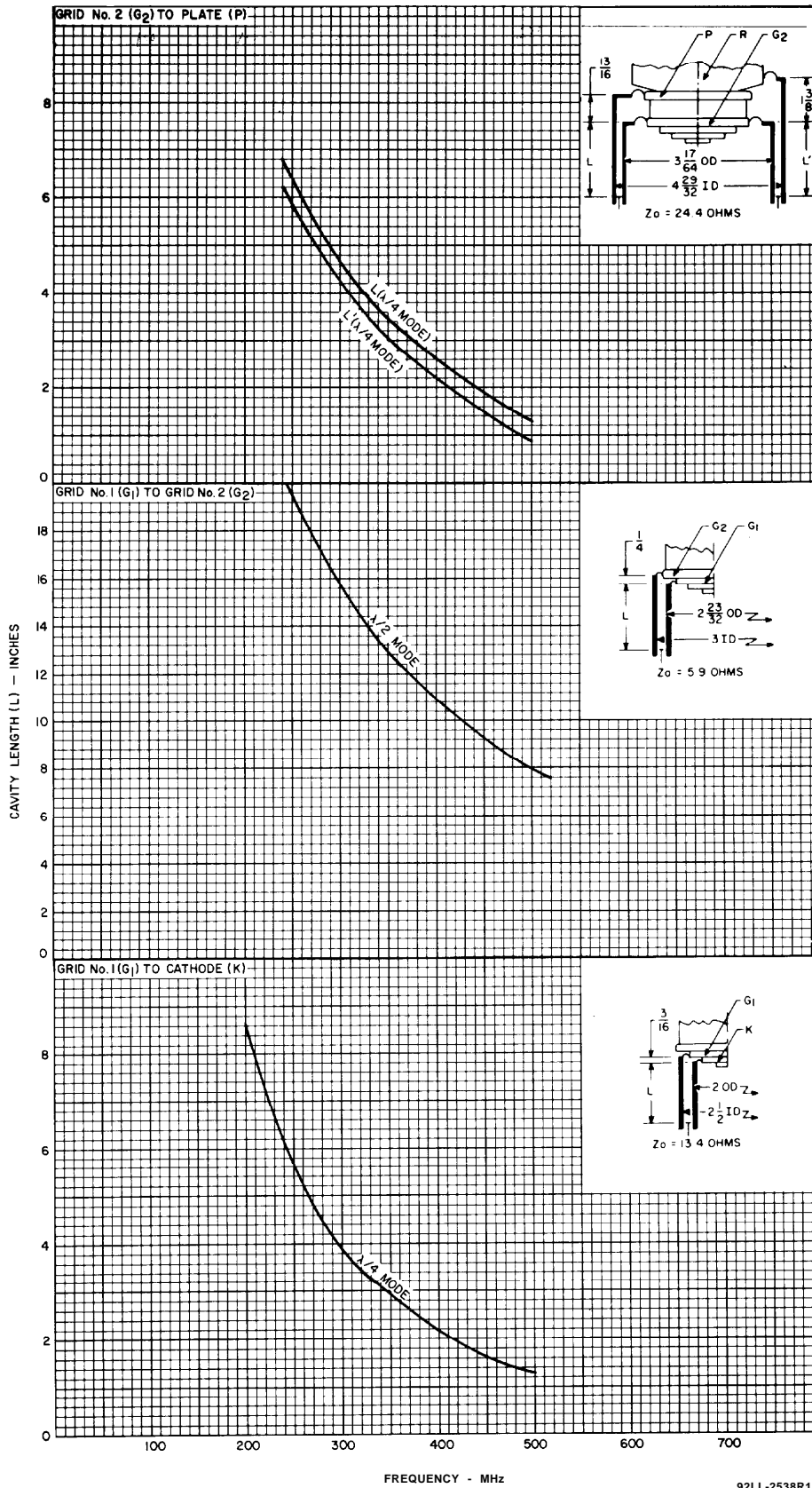

92LL-2538R1

Figure 4 - Electrode Cavity Tuning Characteristics

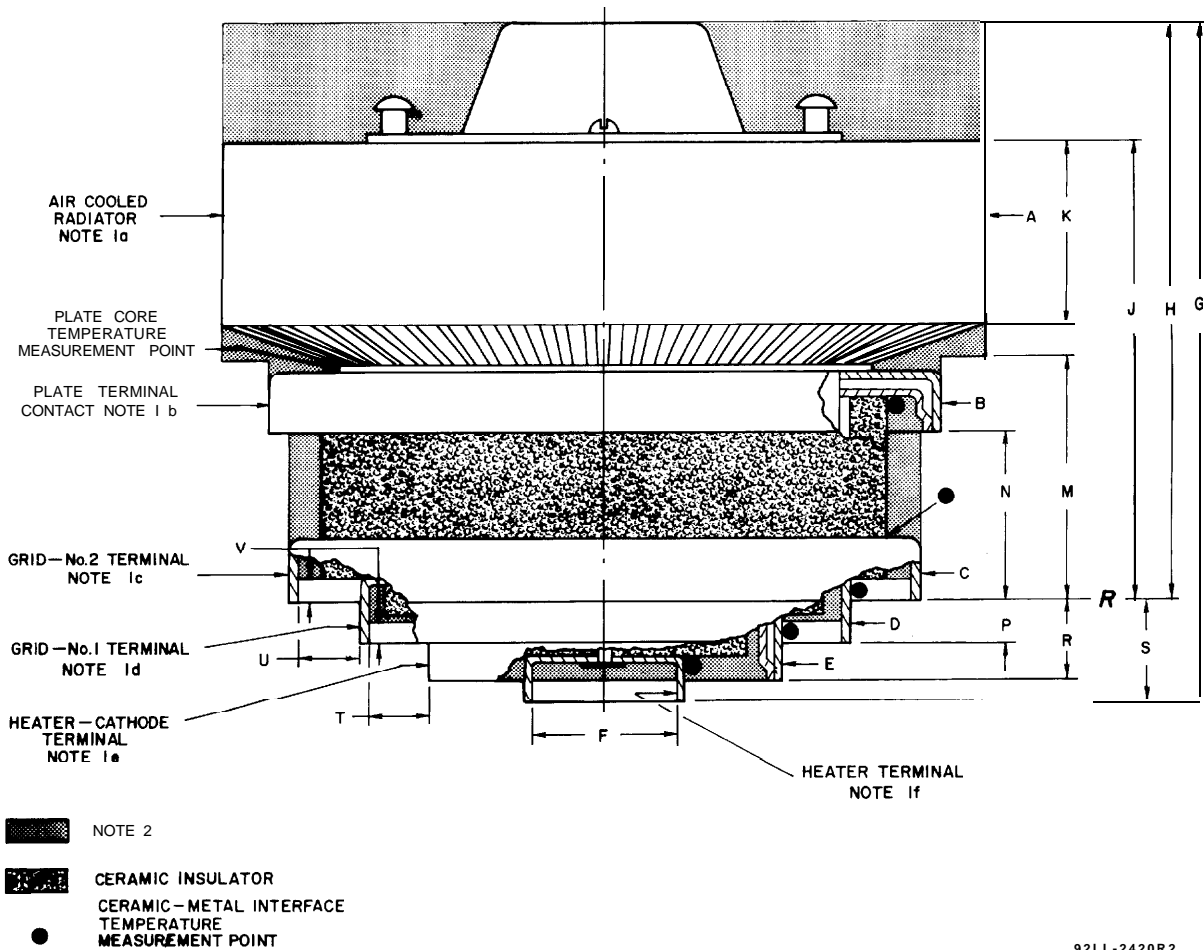

92LL-2420R2

Figure 5 - Dimensional Outline

Tabulated Dimensions*

Dim.	Value		
A	94.49 ± 0.76	(3.72 ± 0.03)	Dia.
B	81.54	(3.210)	Dia. Min.
C	76.45	(3.010)	Dia. Min.
D	58.60	(2.307)	Dia. Min.
E	43.41	(1.710)	Dia. Min.
F	18.41	(0.725)	Dia. Max.
G	82.3 ± 2.5	(3.24 ± 0.10)	
H	70.61 ± 1.78	(2.78 ± 0.07)	
J	55.63 ± 1.02	(2.19 ± 0.04)	
K	21.59 -	(0.85)	Min.
M	29.464 + 0.127	(1.160 + 0.005)	
	-0.000	(-0.000)	
N	20.83 ± 0.76	(0.82 ± 0.03)	
P	5.08 ± 0.63	(0.200 ± 0.025)	
R	9.40 ± 0.76	(0.37 ± 0.03)	
S	11.68 ± 0.76	(0.46 ± 0.03)	
T	5.08 -	(0.200)	Min.
U	6.35	(0.250)	Min.
v	2.66	(0.105)	Min.

Note 1 - The contact distance* indicated is the minimum uniform length as measured from the edge of the terminal.

Note	Element	Contact Distance
1a	Radiator	21.59 (0.850)
1b	Plate Terminal	5.59 (0.220)
1c	Grid No.2 Terminal	5.59 (0.220)
1d	Grid No.1 Terminal	4.45 (0.175)
1e	Heater-Cathode Terminal	2.92 (0.115)
1f	Heater Terminal	3.43 (0.135)

Note 2 - Keep all stippled regions clear. In general do not allow contacts to protrude into these annular regions. If special connectors are required which may intrude on these regions, contact BURLE INDUSTRIES, INC., Tube Products Division Marketing.

* Dimensions in millimeters. Dimensions in parentheses are in inches.

Mounting

See the preferred mounting arrangement below. See TP-105 for a description of the fixed method of mounting. The adjustable method is not recommended for the 8792/V1. Special sockets are available (see page 2).

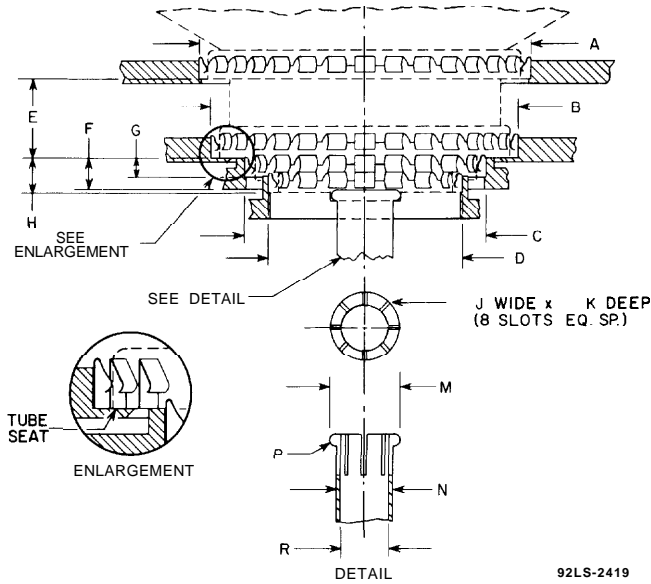

Tabulated Dimensions*

Dim.	Value	
A	87.00	(3.425) Dia.
B	81.53	(3.210) Dia.
C	63.63	(2.505) Dia.
D	48.56	(1.912) Dia.
E	20.83	(0.820)
F	8.38	(0.330)
G	5.08	(0.200)
H	9.40	(0.370)
J	0.64	(0.025)
K	12.70	(0.500)
M	18.42	(0.725) Dia.
N	15.09	(0.594) Dia.
P	1.57	(0.062) Radius
R	12.70	(0.500) Dia.

Note - Finger stock is No.97-360A made by Instrument Specialities Co., P.O. Box A, Delaware Water Gap, PA 18327.

* Dimensions in millimeters. Dimensions in parentheses are in inches.

Figure 6 - Preferred Mounting Arrangement and Layout of Associated Contacts

Forced-Air Cooling

Air Flow

Through Radiator - Adequate air flow to limit the plate-core temperature to 250° C should be delivered by a blower through the radiator before and during application of filament, plate, grid-No.2, and grid-No.1 voltages. In typical operation at 1500 watts, plate dissipation, and 225° C plate seal temperature, 29 cfm at 0.35 inches of water at 28° C ambient air temperatures should be sufficient.

To Plate, Grid-No.2, Grid-No.1, Cathode-Filament, and Filament Terminals - A sufficient quantity of air should be allowed to flow past each of these terminals so that their temperature does not exceed the specified maximum value of 250° C.

During Standby Operation - Cooling air is required when only filament voltage is applied to the tube.

During Shutdown Operation - Air flow should continue for a few minutes after all electrode power is removed.

For further information on forced-air cooling see TP-118, Application Guide for Forced Air Cooling of BURLE Power Tubes.

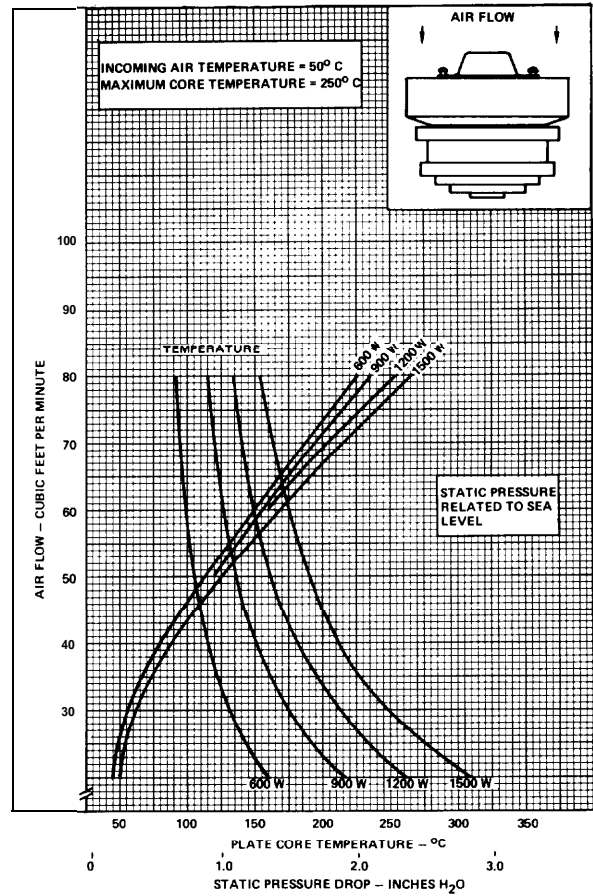

92LM-6491

Figure 7 - Typical Cooling Characteristics