

# 8792 Power Tube

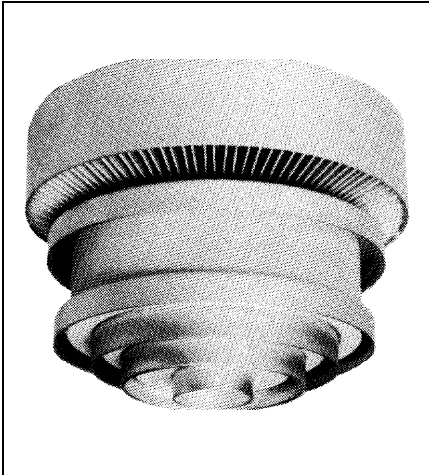

## Linear Beam Power Amplifier Tube

- 1000 Watts Peak Sync Output in VHF Translator Service
- 265 Watt Average-Noise-Power Output with White Noise Loading
- 300 Watt Power Output in UHF-Linear Telephony Service
- 1200 Watts PEP Output in SSB Suppressed-Carrier Service
- CERMOLOX®
- Full Input to 400 MHz

The BURLE 8792 is designed specifically to meet the high linearity and low noise requirements of modern data transmission and communication systems. Its sturdy construction makes it ideal for use in portable or mobile equipments.

The design linearity has been evaluated using Method 2206 of MIL-STD-1311. This method employs white noise with a Gaussian amplitude distribution to check the inherent distortion in power amplifiers over a broad operating spectrum. The 8792 tested better than the -40 dB specified for Government high-performance equipments for data transmission. This test checks the linearity for all methods of modulation both continuous (amplitude, frequency and phase) and also pulse (position, amplitude and duration).

The 8792 is also rated for SSB - suppressed carrier service where it can deliver up to 1200 watts of peak envelope power at a third order intermodulation distortion of -37 dB when tested with "Two Tone Modulation" (Method 2204 of MIL-STD-1311). It can also supply in excess of 300 watts of useful power output in linear telephony applications.

The sturdy, low-inductance, coaxial construction of the 8792 enables the use of simple, economical circuit techniques in all HF, VHF, and UHF applications.

Its large, matrix-oxide cathode enhances system reliability and life, while the efficient forced-air-cooled radiator reduces system air requirements and permits reliable, low-temperature operation.

This bulletin gives application information unique to the BURLE 8792. General information, covering the installation and operation of this tube type, is given in the "Application Guide for BURLE Power Tubes", TP-105. Close attention to the instruc-

tions contained therein will assure longer tube life, safer operation, less equipment downtime, and fewer tube handling accidents.

### General Data

#### Electrical

Heater-Cathode:

Type .....	Unipotential, Oxide Coated, Matrix Type
Voltage <sup>1</sup> (AC or DC) .....	5.5 typ. V 5.8 max. V
Current (@ 5.5 V) .....	17.3 A
Minimum heating time .....	180 s
Mu Factor .....	7
(Grid No.1 to grid No.2)	

Direct Interelectrode Capacitances:

Grid No.1 to plate <sup>2</sup> .....	0.2 max. pF
Grid No.1 to cathode-heater .....	38 pF
Plate to cathode-heater <sup>2</sup> .....	0.03 max. pF
Grid No.1 to grid No.2 .....	52 pF
Grid No.2 to plate .....	16 pF
Grid No.2 to cathode-heater <sup>2</sup> .....	2.0 max. pF

#### Mechanical

Operating Position .....	Any
Maximum Length .....	84.8 mm (3.34 in)
Greatest Diameter .....	95.3 mm (3.75 in)
Terminal Connection .....	See Dimensional Outline
Socket .....	See Mounting Arrangement
Radiator .....	Integral Part of Tube
Weight (Approx.) .....	0.9 kg (2 lbs)

#### Thermal

Seal Temperature <sup>3</sup> .....	250 max. °C
(Plate, grid No.1, grid No.2 cathode-heater, and heater)	
Plate Core Temperature <sup>3</sup> .....	250 max. °C

## Linear RF Power Amplifier<sup>1</sup> Single-Sideband, Suppressed-Carrier Service

### Maximum CCS Ratings, Absolute-Maximum Values

Up to 400 MHz		
DC Plate Voltages <sup>1</sup>	3500	V
DC Grid-No.2 Voltage <sup>1</sup>	1000	V
DC Plate Current at Peak of Envelope <sup>4</sup>	1.25	A
Grid-No.2 Input <sup>1</sup>	50	W
Plate Dissipation	1.8	kW

### Maximum Circuit Values

Grid-No.1 Circuit Resistance:		
With fixed bias	5000	ohms
With cathode bias	Not Recommended	
Grid-No.2 Circuit Impedance	See note 1	
Plate Circuit Impedance	See note 1	

## Typical Class AB, CCS Operation with "Two-Tone" Modulation

In a grid-drive circuit at 30 MHz			
DC Plate Voltage	2500	2500	V
DC Grid-No.2 Voltage	600	600	V
DC Grid-No.1 Voltage <sup>5</sup>	-65	-61	V
Zero-Signal DC Plate Current	0.5	0.6	A
Effective RF Load Resistance	1050	1050	ohms
DC Plate Current at Peak of Envelope	1.0	1.1	A
Average DC Plate Current	.075	0.85	A
DC Grid-No.2 Current at Peak of Envelope	-0.020	-0.022	A
Average DC Grid-No.2 Current	-0.014	-0.017	A
Peak RF Grid-No.1 Voltage	50	47	V
Output Circuit Efficiency (Approx.)	90	90	%
Useful Power Output (Approx.):			
Average	530	600	W
Peak envelope	1060	1200	W
Distortion Products Level <sup>6</sup> :			
Third order	35 <sup>7</sup>	37 <sup>7</sup>	dB
Fifth order	45 <sup>7</sup>	47 <sup>7</sup>	dB
Unbypassed Cathode Resistor	0	0	ohm

## Typical Class AB, CCS Operation with White Noise Loading as Specified in Method 2206 of MIL-STD-1311

At 4.0 MHz			
DC Plate Voltage	2500	2500	V
DC Grid-No.2 Voltage	600	600	V
DC Grid-No. 1 Voltage	-74	-70	V
Zero Signal DC Plate Current	500	600	mA
RF Load Resistance	1500	1000	ohms
Average DC Plate Current	560	695	mA
Average DC Grid-No.2 Current	-10	-11	mA
Driver Power Output <sup>8</sup>	4.5	8.5	W
Output Circuit Efficiency	90	90	%
Noise Power Ratio (NPR)	-40	-40	dB
Unbypassed Cathode Resistor	0	5	ohms
Useful Noise Power Output (NP <sub>0</sub> )	200	265	W

## Linear RF Power Amplifier<sup>1</sup> Class AB or Class B Telephony

Carrier conditions for use with a maximum modulation factor of 1.0.

### Maximum CCS Ratings, Absolute-Maximum Values

DC Plate Voltage <sup>1</sup>	3500	V
DC Grid-No.2 Voltage <sup>1</sup>	1000	V
DC Plate Current	700	mA
Grid-No.2 Input	50	W
Plate Dissipation	1800	W

### Calculated CCS Operation as a Class AB<sub>1</sub> Amplifier

In a cathode drive circuit at 400 MHz with an output circuit bandwidth of 3.5 MHz<sup>9</sup>.

DC Plate Voltage	2600	A
DC Grid-No.2 Voltage <sup>1</sup>	500	V
DC Grid-No.1 Voltage <sup>10</sup>	-65	V
DC Plate Current	550	mA
DC Grid-No.1 Current	0	A
DC Grid-No.2 Current	-10	mA
Drive Power (Approx.)	25	W
Output Circuit Eff. (Approx.)	90	%
Useful Power Output	300	W

## Linear RF Power Amplifier VHF Translator Service, Class AB

Synchronizing-level conditions per tube unless otherwise specified.

### Maximum CCS Ratings, Absolute-Maximum Values

DC Plate Voltage	3500	V
DC Grid-No.2 Voltage	1000	V
DC Plate Current	1.25	A
Plate Dissipation	1800	W
Grid-No.2 Input	50	W

### Typical Operation

In a cathode-drive circuit with video RF drive at 200 MHz and a 1.0 dB bandwidth of 6.5 MHz min.

DC Plate Voltage	2500	V
DC Grid-No.2 Voltage	600	V
DC Grid-No.1 Voltage	-55	V
DC Plate Current:		
Zero signal	0.6	A
Synchronizing level	1.25	A
Pedestal level	0.9	A
DC Grid-No.2 Current:		
Synchronizing level	-50	mA
DC Grid-No.1 Current:		
Synchronizing level	0	mA
Drive Power Output:		
Synchronizing level	63	W
Pedestal level	38	W
Useful Power Output:		
Synchronizing level	1000	W
Pedestal level	600	W
Inter Mod Distortion	-54	dB

Measured with 3 Tone input signal under CCIR conditions. Visual carrier adjusted to -8 dB below 1 kW level. Aural carrier at -7 dB and the color subcarrier at -17 dB.

### Warning - Personal Safety Hazards

**Electrical Shock** - Operating voltages applied to this device present a shock hazard.

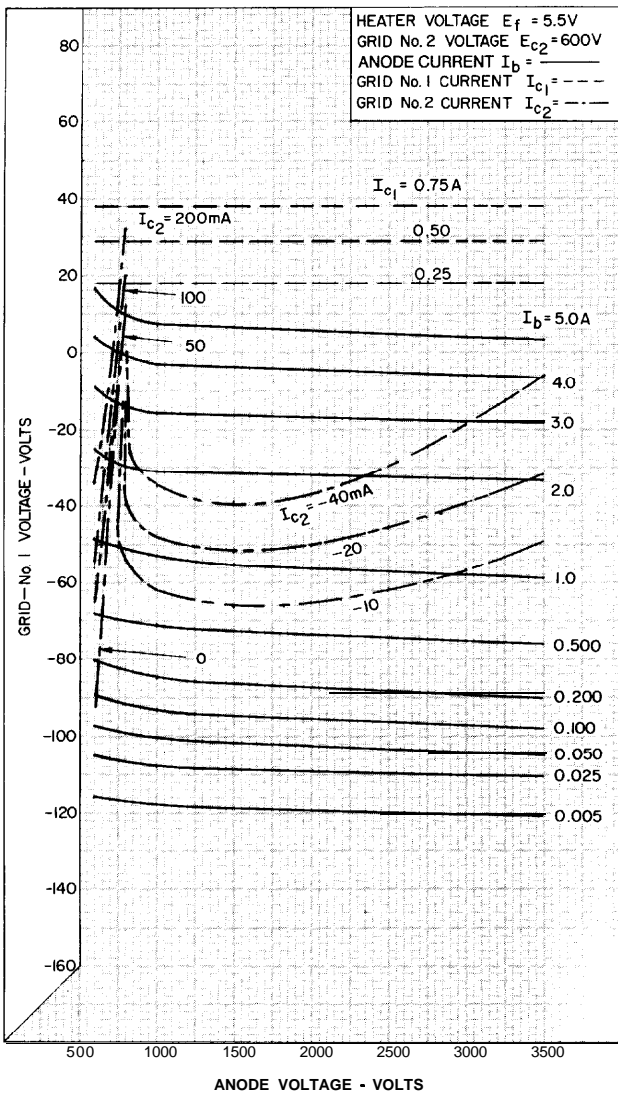

Figure 1 - Typical Constant Current Characteristics ( $E_{c2} = 600V$ )

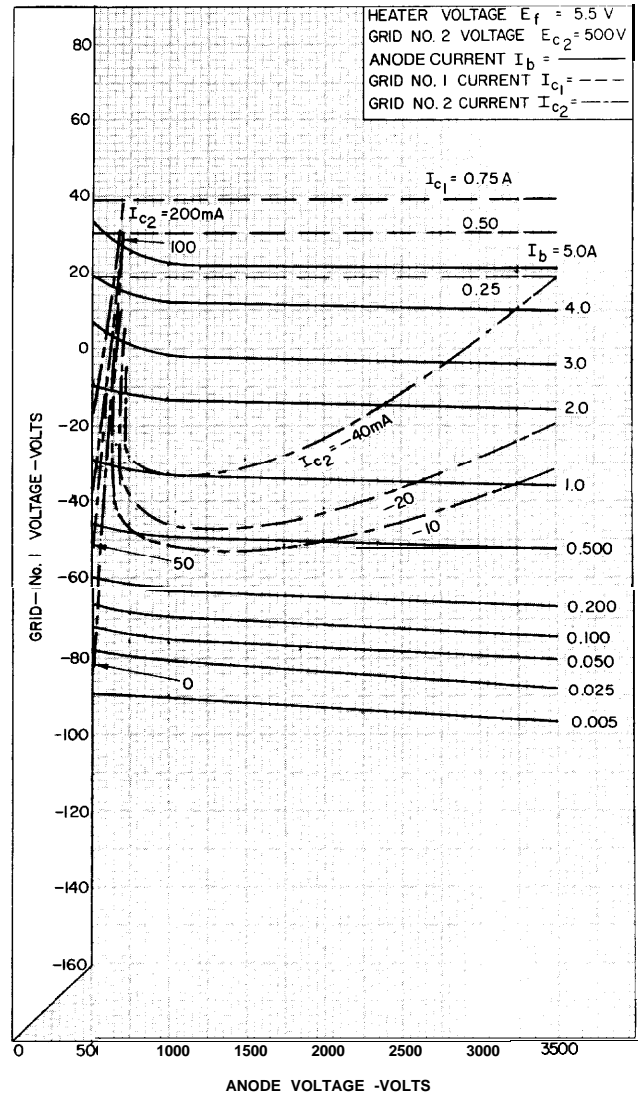
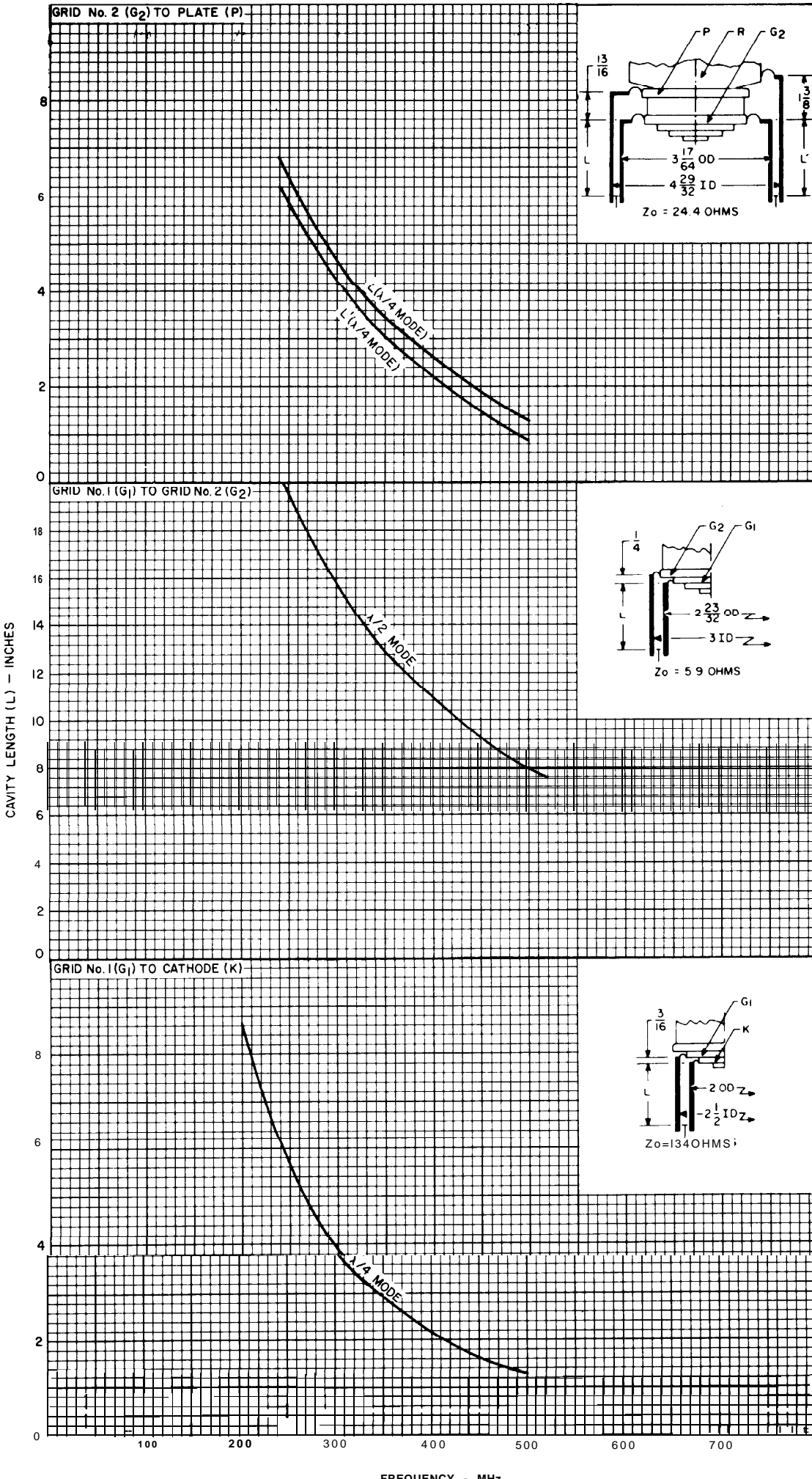
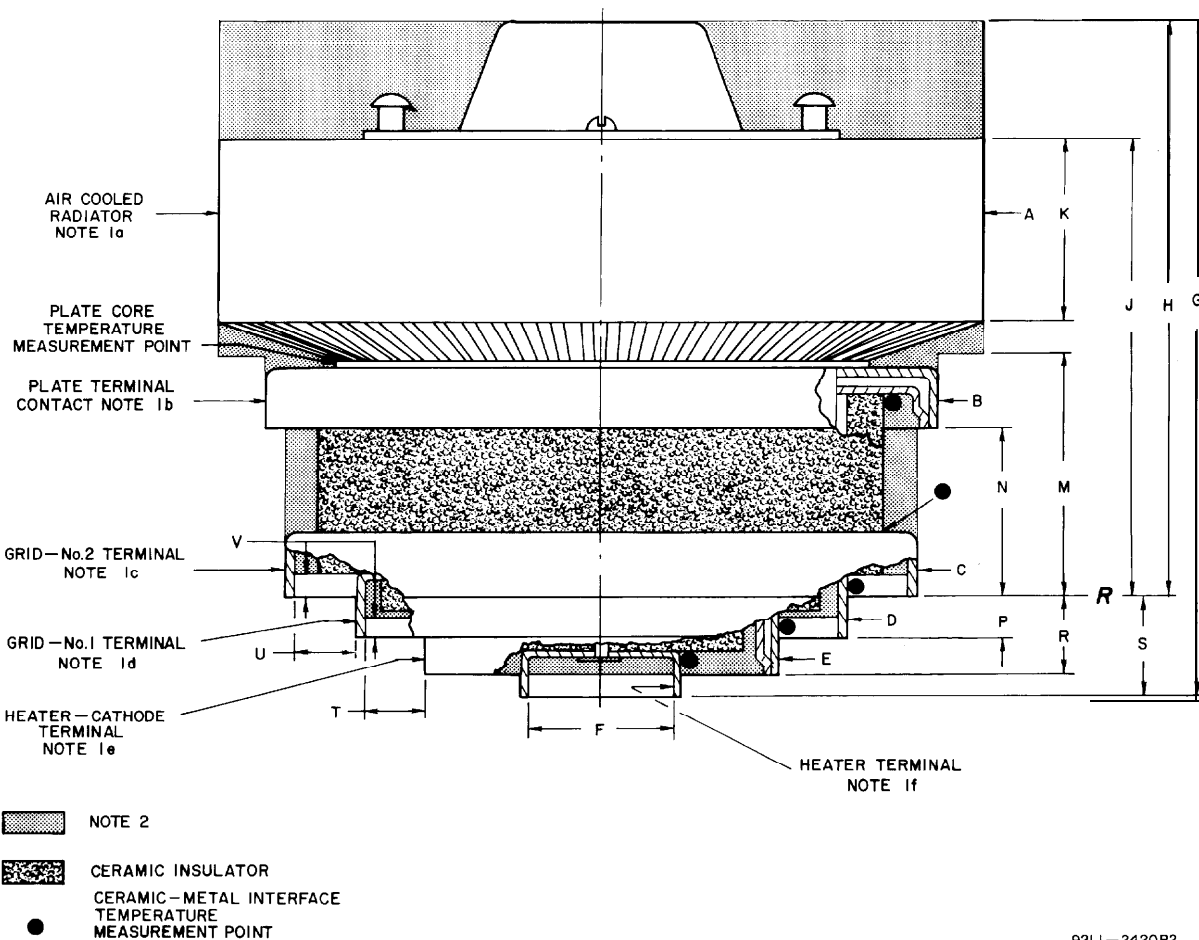

Figure 2 - Typical Constant Current Characteristics ( $E_{c2} = 500 V$ )

1. See TP-105.
2. With special shield adapter.
3. See Dimensional Outline for Temperature Measurement points.
4. During short periods of circuit adjustment under "Single Tone" conditions, the average plate current may be as high as 1250 mA.
5. Adjust to specified zero-signal DC plate current.
6. Referenced to two equal tones (Method 2204, MIL-STD-1311).
7. Measured during open loop operation (no feedback or neutralization employed to enhance performance).
8. Measured across a 50 ohm grid-swamping resistor.
9. Computed between half-power points using two times tube output capacity.
10. Adjust for zero-signal DC plate current of 200 mA.





**Figure 4 - Dimensional Outline**

**Tabulated Dimensions\***

Dim.	Value			
A	94.49 ± .76	(3.72 ± .03)	Dia.	
B	81.54	(3.210)	Dia.	Min.
C	76.45	(3.010)	Dia.	Min.
D	58.60	(2.307)	Dia.	Min.
E	43.41	(1.710)	Dia.	Min.
F	18.41	(0.725)	Dia.	Max.
G	82.3 ± 2.5	(3.24 ± .10)		
H	70.61 ± 1.78	(2.78 ± .07)		
J	55.63 ± 1.02	(2.19 ± .04)		
K	21.59	(0.85)		Min.
M	29.464 + .127 - .000	(1.160 +.005) (-.000)		
N	20.83 ± .76	(0.82 ± .03)		
P	5.08 ± .63	(0.200 ± .025)		
R	9.40 ± .76	(0.37 ± .03)		
S	11.68 ± .76	(0.46 ± .03)		
T	5.08	(0.200)		Min.
U	6.35	(0.250)		Min.
V	2.66	(0.105)		Min.

**Note 1** - The contact distance\* indicated is the minimum uniform length as measured from the edge of the term

	Contact Distance
1.a Radiator	21.59 (0.850)
1.b Plate Terminal	5.59 (0.220)
1.c Grid-No.2 Terminal	5.59 (0.220)
1.d Grid-No.1 Terminal	4.45 (0.175)
1.e Heater-Cathode Terminal	2.92 (0.115)
1.f Heater Terminal	3.43 (0.135)

**Note 2** - Keep all stippled regions clear. In general do not allow contacts to protrude into these annular regions. If special connectors are required which may intrude on these regions, contact BURLE Power Tube Application Engineering, Lancaster, PA for guidance.

\* Dimensions in millimeters, dimensions in parentheses are in inches.

## Mounting

See the preferred mounting arrangement below. See TP-105 for a description of the fixed method of mounting. The adjustable method is not recommended for the 8792. Special sockets are available.

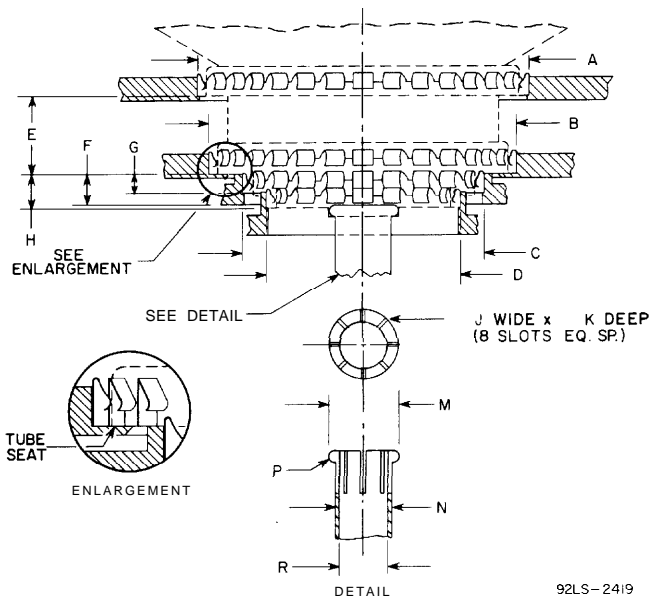

**Figure 5 - Preferred Mounting Arrangement and Layout of Associated Contacts**

### Tabulated Dimensions\*

Dim.	Value	
A	87.00 (3.425)	Dia.
B	81.53 (3.210)	Dia.
C	63.63 (2.505)	Dia.
D	48.56 (1.912)	Dia.
E	20.83 (0.820)	
F	8.38 (0.330)	
G	5.08 (0.200)	
H	9.40 (0.370)	
J	0.64 (0.025)	
K	12.70 (0.500)	
M	18.42 (0.725)	Dia.
N	15.09 (0.594)	Dia.
P	1.57 (0.062)	Radius
R	12.70 (0.500)	Dia.

**Note:** Finger stock is No.97-360A made by Instrument Specialities Co., Little Falls, NY 97424.

Sockets may be obtained from: Jettron Products Incorporated, 65 Route 10, P.O. Box 337, East Hanover, NJ 07938

\* Dimensions in millimeters, dimensions in parentheses are in inches.

## Forced-Air Cooling

### Air Flow:

Through Radiator -- Adequate air flow to limit the plate-core temperature to 250° C should be delivered by a blower through the radiator before and during the application of filament, plate, grid-No.2, and grid-No.1 voltages. In typical operation at 1500 watts, plate dissipation, and 225° C plate seal temperature, 35 cfm at 0.5 inches of water at 28° C ambient air temperatures should be sufficient.

To Plate, Grid-No.2, Grid-No.1, Cathode-Filament, and Filament Terminals --A sufficient quantity of air should be allowed to flow past each of these terminals so that their temperature does not exceed the specified maximum value of 250° C.

During Standby Operation-- Cooling air is required when only filament voltage is applied to the tube.

During Shutdown Operation --Air flow should continue for a few minutes after all electrode power is removed.

For further information on forced-air cooling, see TP-118, Application Guide for Forced-Air Cooling of BURLE Power Tubes.

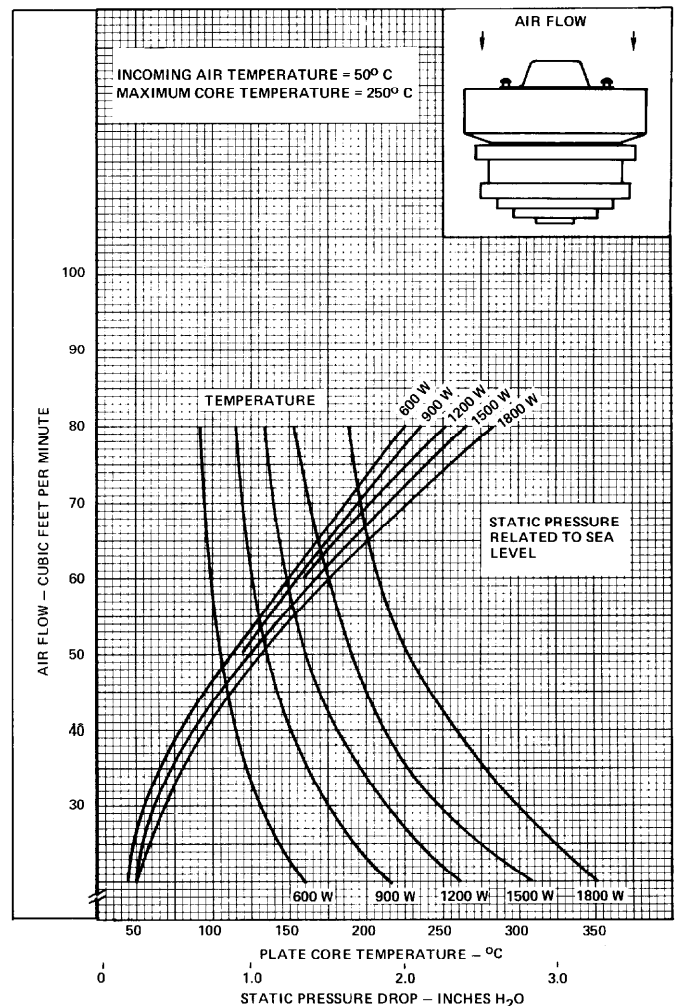

**Figure 6 - Typical Cooling Characteristics**

92LM-2439R3