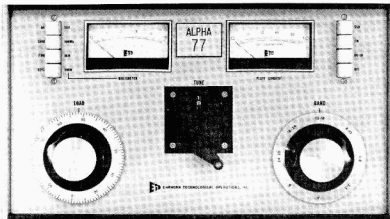


INSTRUCTION AND TECHNICAL MANUAL

MODEL PA-77 LINEAR POWER AMPLIFIER



EHRHORN TECHNOLOGICAL OPERATIONS, INC.  
BROOKSVILLE, FLORIDA 33512

November 1, 1972

TABLE OF CONTENTS

TABLE OF CONTENTS . . . . .	i
STANDARD WARRANTY . . . . .	ii
SECTION 1 - GENERAL DESCRIPTION AND SPECIFICATIONS. . . . .	1
SECTION 2 - INSTALLATION . . . . .	2
REAR PANEL INTERCONNECTIONS . . . . .	4
SECTION 3 - OPERATION . . . . .	5
CONTROL FUNCTIONS . . . . .	5
TUNE-UP PROCEDURE . . . . .	6
FINAL OPERATIONAL ADJUSTMENTS, MONITORING	8
PROTECTIVE DEVICES, OPERATING PRECAUTIONS	9
SECTION 4 - MAINTENANCE AND TROUBLESHOOTING . . . . .	12
SECTION 5 - THEORY OF OPERATION . . . . .	14
SECTION 6 - ILLUSTRATIONS . . . . .	19
TOP VIEW . . . . .	19
BOTTOM VIEW . . . . .	20
REMOVAL OF POWER SUPPLY . . . . .	21
CIRCUIT DIAGRAM (SCHEMATIC) . . . . .	22

S T A N D A R D   W A R R A N T Y

EHRHORN TECHNOLOGICAL OPERATIONS, INC. (ETO) warrants each new product manufactured by it to be free from defective material or workmanship and agrees to remedy any such defect or to furnish a new part in exchange for any part of any unit of its manufacture which under normal installation, use, and service discloses such defect, provided the unit is delivered by the owner to us or to our authorized dealer or distributor from whom purchased, intact, for our examination, with all transportation charges prepaid, within ninety days from the date of sale to original purchaser, provided that (1) such examination discloses in our judgment that it is thus defective and that (2) a properly completed warranty registration form has been mailed to ETO within five (5) days after date of sale to original purchaser.

NOTE: Do not under any circumstances return equipment to ETO without receiving explicit authorization for such return from us in advance. Shipment of equipment in other than approved factory packing may void this warranty. Should a malfunction be suspected, contact your selling dealer or the ETO service department with full details of the difficulty before attempting repairs or return for service.

This warranty does not extend to any of our products which have been subjected to misuse, neglect, accident, incorrect wiring not our own, improper installation, or to use in violation of specifications and instructions furnished by us, nor to units which have been repaired or altered outside our factory, nor in cases where the serial number thereof has been removed, altered, or defaced, nor to units used with accessories not manufactured or recommended by us, nor to the high power transmitting tube(s).

Transmitting tubes are warranted by their manufacturer and the warranty is administered by ETO.

This warranty is in lieu of all other warranties expressed or implied and no representative or person is authorized to assume for ETO any other liability in connection with the sale of our products.

ETO reserves the right to make such changes or improvements to its products which it may deem desirable, without obligating itself to make such changes or improvements available for its previously manufactured products.

EHRHORN TECHNOLOGICAL OPERATIONS, INC.      BROOKSVILLE, FLORIDA

## SECTION 2

### INSTALLATION

1. Unpacking: Open the marked end of both outer and inner cartons and carefully remove the plastic-wrapped amplifier. If difficulty is experienced, it may be necessary to also open the opposite end of both cartons so that the unit may be pushed out.

SAVE ALL PACKING MATERIAL FOR RE-USE; ANY SHIPMENT OF THE ALPHA 77 IN OTHER THAN FACTORY-DESIGNED PACKING MAY VOID THE WARRANTY.

Carefully inspect for shipping damage. Remove the single screw securing the top cover and slide the cover open. REMOVE THE FOAM BLOCK WEDGED BETWEEN THE PLATE COIL AND THE AIR EXHAUST ASSEMBLY. To insure that the 8877 amplifier tube is properly seated in its socket, grasp the stainless steel anode clamp ring securing the bottom of the red silicone rubber air exhaust hood and press firmly downward. The hood should be smooth and free of wrinkles. Make certain that the vacuum variable capacitor (in the lower, right-hand corner of the rf compartment) is securely fastened and operates smoothly when the "TUNE" crank is rotated.

In the event of damage, notify the transportation company immediately. Complete and mail the warranty registration form to ETO within 5 days; no warranty claim(s) can be considered otherwise.

Close and fasten the top cover, confirming that its rear lip contacts and actuates the a-c interlock near the cool air intake.

2. Physical Installation: The ALPHA 77 must be located so that intake of cool air and exhaust of hot air behind the rear panel is not impeded in any way, and so that hot air exhaust will not significantly recirculate into the cool air intake. Under no circumstances should the back of the amplifier be less than six inches from any wall, draperies, or other obstructions. A two-inch copper "bend" or elbow, either 22 $\frac{1}{2}$ <sup>o</sup> or 45<sup>o</sup> "DWV" type as available from plumbing supply houses, may be used to deflect the exhaust air flow if necessary.

Room heating may be virtually eliminated as a by-product of amplifier operation, and cooling system noise even further cut, if exhaust air is ducted outdoors using a suitable duct not less than three inches in inside diameter. Significant back pressure must not be generated; electric dryer vent fittings with magnetic-latching outside flaps, for example, are intolerable, as they will prevent adequate air flow and may result in serious damage to the tube and the amplifier. Normal blower speed should be increased slightly when exhaust air is ducted more than a few inches; check with your dealer or the E.T.O. factory for advice.

## SECTION 2

### INSTALLATION

1. Unpacking: Open the marked end of both outer and inner cartons and carefully remove the plastic-wrapped amplifier. If difficulty is experienced, it may be necessary to also open the opposite end of both cartons so that the unit may be pushed out.

SAVE ALL PACKING MATERIAL FOR RE-USE; ANY SHIPMENT OF THE ALPHA 77 IN OTHER THAN FACTORY-DESIGNED PACKING MAY VOID THE WARRANTY.

Carefully inspect for shipping damage. Remove the single screw securing the top cover and slide the cover open. REMOVE THE FOAM BLOCK WEDGED BETWEEN THE PLATE COIL AND THE AIR EXHAUST ASSEMBLY. To insure that the 8877 amplifier tube is properly seated in its socket, grasp the stainless steel anode clamp ring securing the bottom of the red silicone rubber air exhaust hood and press firmly downward. The hood should be smooth and free of wrinkles. Make certain that the vacuum variable capacitor (in the lower, right-hand corner of the rf compartment) is securely fastened and operates smoothly when the "TUNE" crank is rotated.

In the event of damage, notify the transportation company immediately. Complete and mail the warranty registration form to ETO within 5 days; no warranty claim(s) can be considered otherwise.

Close and fasten the top cover, confirming that its rear lip contacts and actuates the a-c interlock near the cool air intake.

2. Physical Installation: The ALPHA 77 must be located so that intake of cool air and exhaust of hot air behind the rear panel is not impeded in any way, and so that hot air exhaust will not significantly recirculate into the cool air intake. Under no circumstances should the back of the amplifier be less than six inches from any wall, draperies, or other obstructions. A two-inch copper "bend" or elbow, either 22 $\frac{1}{2}$ <sup>o</sup> or 45<sup>o</sup> "DWV" type as available from plumbing supply houses, may be used to deflect the exhaust air flow if necessary.

Room heating may be virtually eliminated as a by-product of amplifier operation, and cooling system noise even further cut, if exhaust air is ducted outdoors using a suitable duct not less than three inches in inside diameter. Significant back pressure must not be generated; electric dryer vent fittings with magnetic-latching outside flaps, for example, are intolerable, as they will prevent adequate air flow and may result in serious damage to the tube and the amplifier. Normal blower speed should be increased slightly when exhaust air is ducted more than a few inches; check with your dealer or the E.T.O. factory for advice.



3. Electrical Installation: (See illustration on next page)

A-C Power - The ALPHA 77 is designed for operation from a 220 to 250 volt, 50 to 60 Hz, three wire single phase source. With proper adaptation it may also be operated from 120/208 volt three phase power, or from two wire 110-125 or 220-250 volt power. IF TWO WIRE OR THREE PHASE PRIMARY POWER MUST BE UTILIZED, CONTACT THE ETO FACTORY FOR SPECIFIC INSTRUCTIONS!

For normal 220-250 volt 3 wire operation, service wiring should be no smaller than three wire #12 AWG copper in order to insure good regulation; line protection by standard (not slow blow) 20 ampere fuses or circuit breaker is desirable. When installing a suitable power plug on the cable supplied, be certain that the green wire connects to power neutral.

RF OUT - DO NOT OPERATE THE AMPLIFIER AT ANY TIME WITHOUT A PROPERLY IMPEDANCE-MATCHED LOAD CONNECTED TO THIS RECEPTACLE. Use a standard PL-259 "UHF type" plug and RG-8/U coaxial cable, or equivalent, to connect to the antenna or dummy load.

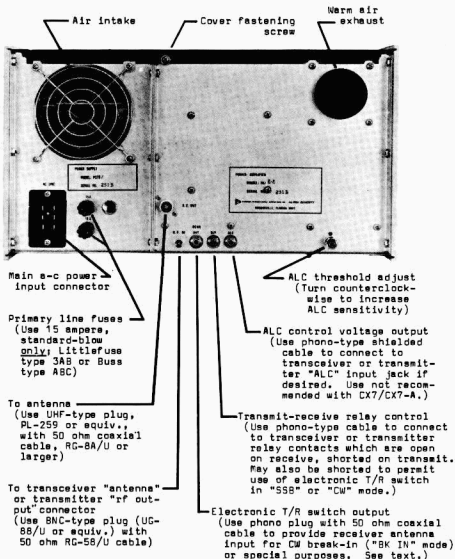
RLY - An external short across this line, usually by means of transmit-receive relay contacts in the exciter (or transceiver), places the ALPHA 77's internal transmit-receive relays in the transmit condition. In the receive condition, then, the antenna is fed back to the RF IN jack as required by most popular transceivers and transmitter-receiver combinations.

RF IN - The RF output of the exciter or transceiver is connected to this jack using a standard "BNC" type plug and RG-58/U coaxial cable, or equivalent. With the ALPHA 77 OFF, or in CW or SSB with the external relay line not shorted (normal receive condition), the antenna connected to the amplifier is fed back through the internal relays to the RF IN jack to provide normal receiver or transceiver received-signal input from the antenna.

RCVR ANT - The output of a built-in electronic T/R switch is available at this jack to provide receiver signal input for full break-in keyed CW operation, provided that (1) the internal T/R changeover relays of the ALPHA 77 are in the transmit condition, (2) operation is in or near the amateur 3.5, 7, 14, 21, or 28 MHz bands, and (3) the ALPHA 77 is properly adjusted (tuned and loaded) for operation on the band to be received. When the ALPHA 77's BK-IN button is pushed the internal T/R relays are automatically locked in the transmit condition to permit use of this feature and receiver antenna input is available only at the RCVR ANT jack. This feature is most useful only when used with an exciter or transceiver which is itself capable of true instantaneous CW break-in operation (the Signal/One CX7, for example). When the exciter or transceiver employs manual or "VOX" delay T/R switching on CW (KWM-2, Heath SB-series, Drake T-4 or TR-series, etc.), it will be most convenient to simply employ conventional T/R control with the ALPHA 77 as described under "RLY" above.

ALC - Provides control voltage for use with suitably-equipped exciters/transceivers such as Collins, Heath. Not recommended with Signal/One CX7. Threshold-adjust adjustment on rear panel.

## ALPHA 77 REAR PANEL

INTERCONNECTIONS WITH TRANSCEIVERS, TRANSMITTERS, AND RECEIVERS

SECTION 3

OPERATION

1. Control Functions:

- a. MODE CONTROL PUSH BUTTONS -- The four buttons to the right of the PLATE CURRENT meter control power on-off and operational mode of the ALPHA 77.

OFF - Fully depressing this button switches off all a-c power. The button illuminates red whenever (1) all four buttons are out, (2) the plate overcurrent relay has actuated, popping out the previously-selected mode button, or (3) the top cover interlock switch is open and one of the mode buttons pressed. When all four buttons are out (accomplished by lightly pressing any one of them which is not already depressed), the cooling blower operates but all other a-c power is removed.

BK-IN - Sets up amplifier operating conditions exactly like CW button (see next paragraph below) except that internal T/R changeover relays are locked in the transmit condition so that receiver antenna input is available at RCVR ANT jack for full break-in CW operation without the necessity for providing an external short on the RLY line. Receiver input is not available at the RF IN jack in this mode.

CW - Applies proper plate and bias voltages for operation at up to approximately 1.5 kilowatts input PEP or carrier (CW, FSK, SSTV, SSB, etc.) continuous duty. Transmit-receive (T/R) switching operation is "normal," with an external contact closure on the RLY line required for transmit and receiver antenna input provided to the RF IN jack on receive.

SSB - Applies proper plate and bias voltages for continuous duty SSB voice operation at inputs up to 3 kilowatts PEP, 1.5 kilowatts average. T/R control functions same as described above under CW.

- b. METER PUSH BUTTONS -- These four buttons switch the multimeter to indicate high voltage (HV - 5000 VDC full scale), grid current (GRID - 500 full scale), forward RF power (FWD - 5 KW full scale), or reflected RF power (REFL - 500 watts full scale). HV and GRID indications are referenced to the 0-5 black meter scale, FWD and REFL refer to the red RF WATTS scale.
- c. LOAD -- Controls plate loading, which is minimum (corresponding to maximum loading capacitance) when set at or near zero dial reading and maximum at the high-numbered end of the scale. Clockwise rotation always increases plate loading.
- d. TUNE -- Counter dial controls the vacuum variable plate tuning capacitor. Maximum capacitance occurs at full counterclockwise rotation, corresponding to near-zero counter readings.



e. BAND -- The approximate amplifier plate tuning/loading range available is indicated in MHz on the skirt of the knob. Thus the 20 meter (14 MHz) amateur band is covered in the 12-18 band.

2. Tune-Up Procedure:

a. GENERAL -- Correct loading adjustment and drive level is extremely important to insure that any power amplifier will handle its rated power without damage or excessive distortion. Unless an in-line oscilloscope is used continuously to insure proper amplifier operation, it is absolutely essential that plate tuning and loading be initially adjusted at a carefully controlled level of excitation (as indicated by d-c grid current) and that operating drive level thereafter be closely monitored to insure that it does not exceed the maximum which can be handled safely and linearly by the amplifier under that particular set of adjustments.

b. METER READINGS -- When operating with a transmitted signal of steady, unvarying amplitude - such as key-down carrier on CW or FSK - amplifier operating conditions are accurately shown by the monitoring meters. With a rapidly-varying SSB signal, however, the instantaneous current and power levels which actually occur are much greater in magnitude than the values indicated by the meters, since the mechanical inertia of a meter prevents its following a rapidly changing signal. In general the actual peaks of grid and plate current are at least two to three times as great as indicated by the meters.

It is therefore essential that the tuning instructions given below be followed faithfully to insure low distortion operation without danger of damaging the ALPHA 77. The use of a monitoring RF oscilloscope will of course permit some further refinement of adjustments under actual operating conditions.

c. INITIAL TUNE-UP --

(1) Press OFF and HV push buttons; connect a-c power cord.

(2) Set BAND, TUNE, and LOAD controls to the appropriate preliminary settings shown below for the band in use.

<u>BAND</u> (MHz)	<u>TUNE</u>	<u>LOAD</u>	<u>(TEST FREQ.)</u>
3-5	100	55	3.8
5-8	170	60	7.2
8-12	170	70	-
12-18	175	55	14.2
18-24	180	65	21.3
24-30	210	75	28.6

\*NOTE: "TEST FREQ." is that at which these settings should be very nearly accurate when feeding a 50 ohm, matched resistive load.

- (3) Insure that a suitable matched load for the frequency to be used is connected to the amplifier's RF OUT jack.
- (4) Leaving the ALPHA 77 off, tune exciter for normal operation in accordance with its manufacturer's instructions. Then, with exciter delivering rated carrier output (thru the "off" amplifier) to the load ...
- (5) Press first the amplifier's FWD multimeter button and then REFL, noting the respective meter deflections. Reduce exciter output to zero and return it to standby condition. If the REFL deflection exceeds the FWD indication, load SWR is excessive (more than 2:1) and must be corrected before proceeding with tune-up of the ALPHA 77.
- (6) Press HV and CW buttons; both buttons should light up and the multimeter should indicate approximately 2.4 KV. Press SSB and confirm approximately 3.7 to 4.0 KV HV indication. Press CW again and allow 80 to 120 seconds, as required, for the ALPHA 77's warm-up delay relay to close.

NOTE: Until the delay relay closes, and whenever the grid overcurrent relay has tripped, the amplifier's internal T/R changeover relays are locked in the "receive" condition; any applied drive power will simply be fed through to the load. It is important that drive power not be present at the moment of T/R relay closure, or damage to the vacuum relays will result from "hot switching." RF output from high power exciters or transceivers must also be reduced to a level suitable for driving the ALPHA 77 before the T/R relays close and drive is applied to the amplifier.

To avoid damage, the amplifier's external relay control line (to RLY jack) should be manually disabled (with a switch or by unplugging it) whenever the exciter is operated "straight through" while waiting for the ALPHA 77's delay relay to close.

- (7) Press GRID button. With exciter in the unmodulated carrier mode ("Tune," "CW," or "Lock Key," depending on its model), slowly increase carrier output until the ALPHA 77 GRID multimeter indication is "1" (100 ma) on the black scale. Rotate TUNE crank to the plate current dip, which should be found within a turn or two of the preliminary settings. Reduce exciter output control to maintain 100 ma GRID current indication, and repeat this exciter output adjustment after every change in tuning and/or loading which results in an indication above 150 ma or below 80 ma.

NOTE: Momentary grid current indicating in excess of about 350 ma will actuate the grid overcurrent relay, automatically latching the ALPHA 77 in the "receive" condition; drive power will feed through to the load but the amplifier cannot be driven to grid or plate current until the overcurrent relay is reset by turning the amplifier OFF for 2 to 3 seconds. After re-pushing the desired mode button a brief period will usually be required for the time delay relay to close again.

- (8) If no clear plate current dip is found near the indicated preliminary setting, press the FWD button and tune for a maximum in indicated RF output power. (This may be necessary if the character of your load differs substantially from 50 ohms resistive or if the operating frequency is far removed from the "TEST FREQ." shown in the chart.) Press GRID button and continue.
- (9) With exciter adjusted to provide 1.5 (150 ma) amplifier GRID current reading at the plate current dip, note the plate current. If less than 0.650 amperes (about 2/3 of full scale on the plate current meter), increase loading by slight clockwise rotation of the LOAD knob (toward a higher dial reading on the knob skirt), then re-dip plate current with the TUNE crank.
- (10) Repeat step (9) until 0.650 amperes plate current at the TUNE dip is achieved with 150 ma GRID reading. If at any time plate current at the dip (with 150 ma GRID) is more than 0.650 amperes, reduce loading by slight reduction in the LOAD knob reading and repeat as in (9) until the desired plate and grid currents occur together.
- (11) Press HV button and confirm that voltage under 0.650 amperes plate current load is approximately 2000. NOTE: Since this tune-up procedure results in plate input substantially in excess of one kilowatt, it cannot be legally performed into an antenna by amateur service stations. Stay legal and avoid unnecessary tune-up interference by using a dummy load for initial tune-up. Inexpensive units such as the Heathkit "Cantenna" are entirely suitable for such use.
- (12) The ALPHA 77 is now properly adjusted for high power SSB, CW, FSK, SSTV, and other services. See the instructions which follow for further details on each individual mode and on amateur service operation. Turn off exciter.

### 3. Final Operational Adjustments and Monitoring:

- a. HIGH POWER SSB -- ALL SERVICES -- After completing preliminary tune-up as above, press SSB button. With exciter in SSB mode, using either a two-tone test signal or normal speech into the microphone, slowly increase exciter output while watching the ALPHA 77 plate current meter.
  - (1) For legal amateur operation at 1 KW d-c input, adjust excitation level so that occasional highest plate meter peaks reach approximately 0.200 to 0.250 amperes, typically corresponding to peak envelope power (PEP) inputs in excess of 2 KW.
  - (2) For SSB operation at maximum rated input, adjust excitation for highest plate current peaks of approximately 0.4 amps, typically corresponding to PEP inputs exceeding 3 KW.



NOTE: GRID OVERCURRENT RELAY KICK-OUT DURING SSB OPERATION is a clear and definite indication of excessive drive power, at least on peaks, for the degree of amplifier loading employed. This problem will not generally occur when employing exciters or transceivers in the 100 watt class, such as Collins S-Line and Heath SB-Line units. Nor will it occur with higher-power drivers employing properly-adjusted rf envelope clipping. The CX7/CX7-A, and other exciters or transceivers employing auxiliary rf clippers such as the Comdel and DX Engineering units, should be set for moderate clipping -- at least 8-12 db -- while the SSB rf output level is adjusted as in (2) above. Thereafter the output control should never be set above this pre-set point, although it may be reduced, and the clipping varied up or down, at will. Heavier plate loading in step (10) above will also permit operation at greater excitation and plate power input levels than specified, under certain conditions. Contact the ETO factory for information on specific applications.

- b. CW, FSK, SSTV, OR NBFM OPERATION -- AMATEUR SERVICE -- For maximum efficiency at one kilowatt carrier or "key down" input, perform initial tune-up in section 2.c above for an amplifier plate current of 0.400 to 0.450 amperes at the dip, maintaining indicated grid current at 100 to 150 ma as before. Operate at this level in the CW mode; switching to SSB, it is possible to run approximately 2 kilowatts PEP input without re-adjustment or excessive distortion (corresponding plate current meter peaks should not exceed 0.200 amperes).
- c. CW, FSK, SSTV, OR NBFM OPERATION --MAXIMUM RATED POWER -- Maintain approximately 0.650 to 0.700 ampere plate current and 150 ma grid current, using CW mode only, for continuous service. For intermittent service (50% duty cycle, 5 minutes maximum on, 5 minutes off) the SSB mode may be used, loading for 0.500 ampere plate current and not more than 100 ma grid current.
- d. AM LINEAR (DSB OR SSB, WITH CARRIER) OPERATION -- While the ALPHA 77 is capable of providing as much as 15 decibels power gain (30 X) with a 100% amplitude modulated signal, proper tuning and drive adjustment is rather more critical than in other types of operation. If such operation is contemplated, contact the ETO factory for specific instructions.

#### 4. Protective Devices and Operating Precautions:

- a. PRIMARY FUSES -- The primary a-c line input to the ALPHA 77 is provided with 15 ampere, 250 volt, standard-blow fuses, either Littlefuse type 3AB or Buss type ABC. Do not under any circumstances replace these fuses with slow-blow, glass-body, or higher-capacity types!

The fuses specified will reliably handle any input power level which is not damaging to the ALPHA 77. A blown fuse indicates (1) excessive and unsafe average power input, (2) component failure, or (3) a power surge, such as due to lightning.



- b. PLATE OVERCURRENT BREAKER -- If amplifier plate current substantially exceeds safe operating levels (approximately 1.0 ampere for brief "key down" periods or 1.3 amperes peak) the plate current protective system will trip, as indicated by "kicking-out" of the previously-depressed mode pushbutton. The OFF pushbutton is illuminated red and power is removed from all circuits except the cooling blower, which continues to operate. After removing excitation and correcting the cause of overload, the ALPHA 77 may be returned to service by simply pressing the desired mode button and waiting for the time delay to close. (See paragraph d. below.)
- c. GRID OVERCURRENT BREAKER -- As described previously (pages 7 and 9) this relay trips when grid current exceeds about 350 ma. Since no useful purpose is ever served by operating at peak d-c grid current in excess of 200 ma (as would be indicated on the grid current meter if it were physically capable of following instantaneous current variations during voice operation), tripping of this highly-reliable grid relay should be taken as a strong indication of improper operating conditions!

Tripping of the grid overcurrent relay is indicated by latching of the amplifier in the "receive" condition and, in late production amplifiers, by extinguishing of the meter illuminating lamps. The most probable causes are substantially excessive drive power, too-light plate loading (or both), or an incorrect or defective load. (See discussion at top of page 9.) To reset the grid relay, press OFF, wait 2-3 seconds, then press desired mode button and wait for the time delay to close.

- d. WARM-UP TIME DELAY -- The rugged, high-gain, high-linearity Eimac 8877/3CX1500A7 amplifier tube employed in the ALPHA 77 requires approximately 90 seconds' filament warm-up prior to application of r-f drive. Until the internal electronic time delay circuit operates, the ALPHA 77's T/R changeover relays are locked in the "receive" condition (see page 7, para. 6). In late production amplifiers the meter-illuminating lamps do not light until the time delay closes, thus providing a "ready" indication.

When amplifier power is off for any length of time, the time delay begins to reset. Upon re-application of power the time required for the delay relay to close depends upon preceding length of "off" time, and will vary from a few seconds to the full nominal 90 seconds.

- e. AMPLIFIER-READY INDICATION -- During the warm-up time delay period and whenever the grid overcurrent relay is tripped, the ALPHA 77's internal vacuum T/R relays are locked in the "receive" position regardless of mode switch or external relay control line conditions. If excitation is applied, it will be fed directly through to the load without causing grid or plate current to flow (see important note on page 7, para. 6). In late production ALPHA 77's the meter lamps are extinguished during warm-up delay or grid-overcurrent-tripped conditions, and light up when normal operating conditions exist.

- f. DRIVE POWER VERSUS LOADING ADJUSTMENT -- Safe, low-distortion operation of any linear power amplifier demands that plate loading be sufficiently heavy for the drive power level employed, and that resultant operating conditions not exceed maximum safe (or linear) capabilities of the tube and equipment.

The ALPHA 77 incorporates a large margin of safety in all important parameters when operated at or near rated conditions. It is, if anything, less critical of adjustment than other amplifiers of similar power level, with one exception: the ALPHA 77's grid overcurrent relay system will not permit the amplifier to be grossly overdriven into the flat-topping and severe distortion conditions possible with amplifiers not so equipped. It does not under any circumstances limit the power capability of the amplifier, but simply requires that adjustments be reasonably proper for high power operation.

ETO factory personnel will be happy to provide advice and information relative to special applications, or to practical operating-conditions problems not covered in this manual.

SECTION 4

MAINTENANCE AND TROUBLESHOOTING

Most apparent problems with the ALPHA 77 result from users' failure to read and thoroughly digest the contents of this manual, rather than from actual equipment problems.

It is important that the interior of the ALPHA 77, and particularly the high voltage d-c areas of power supply and r-f compartment, be cleaned frequently enough (with a soft brush and vacuum cleaner) to prevent visible accumulation of dust and dirt. If excessive dirt is a problem, contact the factory for air filter recommendations.

The following chart suggests the most probable causes for several common symptoms of apparent operational trouble:

<u>SYMPTOM</u>	<u>PROBABLE CAUSE(S)</u>
1. Amplifier completely inoperative; no pushbutton illumination or high voltage indication; meters dark.	a) Blown primary fuse F1 or F2. b) Improper primary a-c supply connections at power plug. c) Internal plugs P2, P3, or P4 not properly mated.
2. All four right-hand push buttons "out," <u>OFF</u> button illuminated red.	a) Desired button not pressed firmly by operator. b) Plate overcurrent relay actuated.
3. <u>BK-IN</u> , <u>CW</u> , or <u>SSB</u> button depressed and illuminated, but <u>OFF</u> button also illuminated; no high voltage.	a) Top cover a-c power interlock switch not closed; lid loose.
4. Depressed pushbutton illuminated on mode switch but no high voltage, meters and meter buttons dark.	a) One primary fuse blown or one side of a-c line open. b) Incorrect a-c plug wiring.
5. No grid or plate current with normal drive from exciter; amplifier lights up normally and HV normal.	a) No external contact closure on <u>RLY</u> line in <u>CW</u> or <u>SSB</u> mode. b) Time delay relay not closed. c) Grid overcurrent relay actuated. d) Input relay K4 damaged.

<p>6. Low plate current, low or no grid current, excessive drive power required. <u>CAUTION! Damage to PA-77 will result from attempted operation!</u></p>	<p>a) Defective bias switch transistors Q4 and Q5, or associated components, especially diodes D17 or D18.  b) Amplifier on wrong band.  c) Input tuned circuit mis-tuned.</p>
<p>7. Plate current of 20 to 150 madc flows with exciter turned off.</p>	<p>a) Bias switch transistor Q4 or Q5 defective.  b) Leakage (partial short) on cathode line or partial tube grid-cathode short.</p>
<p>8. Plate current meter deflects backwards; HV meter indicates lower than normal no-load voltage without drive.</p>	<p>a) Grid-filament short in tube.  b) Short on cathode line to gnd.</p>
<p>9. Grid or plate overcurrent relay actuates on voice peaks.</p>	<p>a) Excessive drive power.  b) Inadequate loading or plate de-tuned from resonance.  c) Defective antenna or feedline, possibly arcing on peaks.</p>
<p>10. Blower intermittently switches to high speed during operation.</p>	<p>a) Abnormally low speed blower operation. Reduce value of R58 -- contact factory.  b) Amplifier not tuned properly.  c) Air leak due to improperly secured bottom cover.</p>
<p>11. Evidence of excessive tube heating or blower stays on high speed.</p>	<p>a) Blockage of normal airflow.  b) Excessive plate dissipation due to mis-tuning or overdrive.  c) Excessive recirculation of hot exhaust air back to air intake.</p>



## SECTION 5

### THEORY OF OPERATION

1. 8877/3CX1500A7 RF AMPLIFIER CIRCUIT: Referring to the ALPHA 77 schematic diagram, the r-f section of the equipment is to the left, with the 8877 power amplifier itself at the top and the auxiliary circuitry (most of which is physically located on the T/R printed circuit board) below.

With transmit/receive (T/R) changeover relays K4 and K5 in the receive condition shown, r-f from the exciter (or transceiver) arriving at RF IN jack J6 passes via the normally closed contacts of K5 to the rf wattmeter coupler assembly (toroid L13 and associated components) directly to the RF OUT connector J8. Similarly, received signals arriving at J8 from the antenna feed directly through the amplifier to J6, permitting conventional connections for all popular transceivers and transmitter-receiver combinations.

When the T/R relays K4 and K5 are switched to the transmit condition, K5a disconnects J8 and the rf wattmeter from J6 and connects them to the amplifier output. K4a connects the input signal from J6 via blocking capacitor C8 to the cathode of the 8877 tube, which operates as a grounded-grid amplifier. When slide switch S1 is moved toward the tube, a pre-tuned resonant tank circuit with "Q" of approximately two (tapped coil L1 and padder capacitors C1 thru C6) is switched in to maximize amplifier linearity and efficiency. The input tank circuit is factory pre-tuned for the center of each amateur band; for operation at substantially different frequencies the appropriate padder (C1 thru C6) may be re-adjusted for minimum input SWR, or the input tank may be disconnected, with only modest reduction in linearity and efficiency, by positioning the slider of S1 away from the tube.

A pi-L plate tank circuit provides excellent suppression of harmonics in the amplifier output, as well as relatively constant operating "Q" (nominally 15) and impedance matching capability across the entire frequency range. Use of vacuum tuning capacitor C17, with its very low minimum capacitance, small size, and high voltage rating, enhances efficiency on the highest frequency bands by maintaining normal "Q" there; the vacuum capacitor also provides a non-critical tuning characteristic, precise re-settability, and a high degree of freedom from flash-over. A heavy, silver-plated copper coil is used at L4 for efficiency. In the interest of physical compactness without excessive inter-coil stray coupling, husky toroidal inductors are used at L5 (in the 3-5 MHz band, where core losses are insignificant) and at L6, the L-network inductor (where r-f current, and hence core losses, are low because of the very low operating "Q" of the L-network).

Because C19 is switched in only on 8-12 MHz and lower frequency bands, loading adjustment is relatively uniform and non-critical on all bands; C18 provides needed additional capacitance for the 3-5 MHz range.

L8 feeds d-c plate voltage to the 8877 and L9, in combination with C13 and C44, provides additional r-f decoupling. R48 provides

fault current limiting to protect circuit components in the event of momentary high voltage flashover.

The r-f wattmeter circuit is conventional, with C45 providing the reflected power null adjustment and resistors R52 and R51 selected to yield full-scale power of 500 watts reflected and 5000 watts forward.

2. ELECTRONIC BIAS SWITCH: Positive bias is applied to the cathode of the 8877 tube to cut off plate current completely when no r-f excitation is present (thus eliminating heat generation and power waste due to idling plate current, as well as preventing tube idling noise from interfering with proper operation of the electronic T/R switch, as described later). Choke L2 provides r-f isolation for the bias supply and feeds approximately +55 volts d-c, from the power supply via R13, to the 8877 cathode. With no r-f excitation transistor switch Q4-Q5 remains "off," and the full 55 volts is applied to the 8877, completely cutting off plate current.

In order to establish proper operating bias, r-f excitation signal from the output of K4a is sampled via C52/R34, rectified by D17/D18, and the resultant d-c used to switch Q4-Q5 "on." As little as 100-200 milliwatts of drive power is sufficient to fully switch on Q5, which is a type specifically selected because of its very low collector-to-emitter saturation voltage -- about 0.5 volt maximum. C16 is large enough to hold the bias switch "on" while drive is applied, even though the r-f envelope varies at an audio rate.

The cathode-to-grid (grid current) circuit is completed to ground (grid) via R20, across which is developed a d-c voltage proportional to grid current but less than 0.5 volts under all normal operating conditions. Thus, when drive is present and Q4-Q5 switched "on," the operating bias consists of the regulating drop across zener diode D13 (8 to 12 volts, depending on the production series) plus less than one volt drop across Q5 and R20.

The d-c voltage drop across R20 serves two purposes: (1) it is fed to multimeter M2 via R22 to provide a meter indication of d-c grid current, and (2) it drives the grid overcurrent relay driver, Q2.

3. GRID OVERCURRENT RELAY: At low values of grid current Q2 remains cut off. When the drop across R20 due to grid current flow is such as to provide a grid meter indication of approximately 350 to 400 ma, however, Q2 is driven sufficiently into conduction to close relay K8 which is immediately latched shut by its own normally open contacts via R55. C30 provides sufficient time constant to prevent relay actuation by occasional, isolated high-current spikes, and to prevent relay "chattering" upon actuation. Q2-K8 operate from the +18 volt d-c buss regulated by zener D9; once K8 is actuated and latched it may be reset by switching a-c power off long enough for the +18 volt buss to fall below K8's hold-in voltage -- about 5 vdc.

Actuation of K8 opens the coil return of time delay relay K9, thus locking the T/R relays in the "receive" condition until K8 is reset.



4. WARM-UP TIME DELAY: Upon application of primary power to the ALPHA 77, voltage on the +18 volt buss regulated by D9 rises from zero to +18 volts in less than one second, and timing capacitor C24 begins charging through R57. MOSFET Q9 operates as a source follower with the coil of K9 as its load; when the voltage across C24 reaches approximately +9 volts, the voltage across relay coil K9 is sufficient to close its contacts K9a, which latch the relay closed via D15 and R56. When K9a closes, voltage from the +55 volt d-c buss is fed to the T/R relay circuit via R12-C27, as well as (in late production units) to the meter lamps I9 thru I12.
5. ALC RECTIFIER: R-f drive voltage is sampled via capacitive divider C56-C57 and applied to rectifier D19, which is back-biased by d-c voltage from ALC threshold-adjust potentiometer R26. When sampled r-f voltage peaks exceed the diode bias level, the signal is rectified and the negative-going ALC control voltage which results is fed to ALC jack J12. R35-C58 decouple the bias source from the r-f detector, while R54-C59 filter carrier-frequency components from the ALC control signal.
6. T/R RELAY SEQUENCING: Components D32 through D35, C26, C27, and R12 serve to insure that output vacuum T/R relay K5 closes before input relay K4, thus protecting plate circuit r-f components of the amplifier, including K5's contacts, from "hot switching" and momentary unloaded operation. Such a situation may occur when exciter relay sequencing is poor, permitting r-f excitation to be delivered to the amplifier simultaneously with closure of the relay control line.

When +55 vdc is initially applied to the T/R relay system, either by closure of the external relay control line through J7, pushing of the BK-IN button, or "kicking-in" of time delay relay K9, C27 begins charging through D35 and K5, momentarily applying nearly the full 55 volts to K5's coil. Simultaneously C26 begins charging through D32 and R12, generating a voltage drop across R12 which briefly delays closing of K4. As a result, although K4 is smaller and inherently faster than K5, these intentional R-C timing circuits insure that K4 will close several milliseconds after K5.

7. ELECTRONIC T/R SWITCH: In combination with the electronic bias switch, this feature permits the ALPHA 77's T/R relays to be locked in the "transmit" position for full break-in CW, providing receiver input signal at J5 during key-up intervals. With the 8877 tube cut off during periods of no excitation (key up) and K5 closed, received signals from the antenna pass "backwards" through the amplifier pi-L output circuit; in the process the network provides selectivity and a step-up of impedance and voltage.

Because of the extremely high input impedance of transistor Q1, a self-protected, insulated gate MOSFET, a very small coupling capacitance C38 (less than 1 pf) is sufficient to couple the signal to Q1's input gate. Q1 operates as a high-gm source follower to provide near unity voltage gain, low noise, and a low impedance output (J5) to the receiver. Total input capacitance of Q1 is on the order of 10 pf, and is resonated out on each amateur band by the appropriate combination of L10, L11, L12, L14, and L15.

Resistors R11, R47, R4, and R7 -- as well as the "Q's" of the resonating inductors previously mentioned -- are selected to provide relatively uniform overall gain (approximately 0 db to +10 db) across the frequency bands covered, as well as positive stability under all conditions of amplifier and receiver-input tuning.

Under transmitting conditions, back-to-back limiter diodes D20 and D21, combined with the very high series impedance of C38, hold the input voltage to Q1 to approximately 0.7 volts peak, thus protecting both Q1 and the receiver input from damage due to excessive input voltage. Diodes D30 and D31 serve to protect Q1 from damage resulting from potential differences between the chassis of the amplifier and the receiver, particularly at the moment the receiver antenna cable is plugged into J5.

8. BLOWER: Whenever the amplifier is in any condition other than OFF, 120 vac is applied to the blower B1 via R58 (shunted by normally-open thermostat S7). R58 is factory adjusted so that the blower normally operates at much less than full speed, delivering sufficient cooling air for all normal amateur and commercial applications under most conditions. The low speed and extremely high quality of the blower combine to yield a very low operating noise level, further enhanced by the ducting of exhaust air out the rear of the ALPHA 77.

Under conditions of sustained excessive plate dissipation resulting in higher-than-normal exhaust air temperature, thermostat S7 -- located on the exhaust air duct -- closes, switching the blower to full speed until air temperature returns to normal. Any cycling to full speed of the blower under normal operating conditions is an indication of either air-flow blockage or inadequate idling blower speed, and should be corrected promptly. (R58 is mounted vertically, underneath the warm air exhaust duct. To increase blower idling speed, loosen the slider-clamping screw and move the slider slightly downward, then retighten. CAUTION! Always remove the a-c power plug before working inside the ALPHA 77!)

9. POWER CONTROL: Pressing mode buttons BK-IN, CW, or SSB applies operating voltage to main a-c power relay K1 via R3, S9 (the top cover must be closed and the interlock actuated), and S5f-D25, S5d-D24, or S5b-D23, respectively. The series diodes D23-D25, along with R3 and diode D16 across the inductance of relay coil K1, serve to convert the applied a-c voltage to approximately 28 vdc for hum-free operation of the relay. Upon closure of K1, primary voltage is applied to the primary windings of power transformer T1 through step-start resistors R1 and R2. These resistors limit initial inrush current to 12 amperes maximum, regardless of other circumstances in the power supply. Under normal conditions the current drawn by T1 will drop very rapidly as high voltage filter capacitor C36 charges toward full voltage; simultaneously, the drop across R1 and R2 decreases and all transformer voltages approach normal. As the +28 vdc buss approaches normal voltage, relay K2 closes, shorting out R1 and R2; the entire starting sequence requires only a fraction of a second.



10. LOW VOLTAGE D-C SUPPLIES: Diodes D1 and D4, respectively, half-wave rectify a-c outputs from the transformer of 44 volts rms and 22 volts rms, which are filtered by capacitors C39 and C37. The d-c output from D1-C39 is approximately +55 volts, and is utilized for bias and control functions in the r-f section, as previously described in detail. The D4-C37 output of about +28 volts is used to power control relays and lamps in the power supply and control sections.
11. HIGH VOLTAGE SUPPLY: High voltage a-c from T1 is rectified by a full wave bridge circuit, D5 through D8, and filtered by a large-capacitance, oil-filled capacitor, C36. Bleeder R5-R6 serves primarily the safety function of discharging the filter capacitor when power is removed; should the operator open the top cover of the amplifier before C36 is fully discharged through the bleeder, crowbar switch S6 shorts C36 directly to prevent possible personal injury.

In the BK-IN and CW modes relay K3 remains de-energized so that its high-voltage contacts (K3a) connect the lower-voltage transformer tap, approximately 1700-1800 volts a-c rms, to the HV rectifier, yielding approximately 2400 volts d-c output, no load. When the SSB button is pressed, switch section S5a completes the coil circuit of K3, switching the rectifier to the higher-voltage transformer tap. In SSB, with approximately 2600-2800 volts a-c applied, rectifier output at no load is about 3800-4000 volts d-c.

12. HIGH VOLTAGE OVERCURRENT BREAKER: The negative side of the HV supply passes via current-sensing relay K6, plate current meter M1, and choke L2, directly to the cathode of the 8877 tube. Shunt resistor R42 is selected so that K6 closes at approximately 1.3 amperes of plate current. When this occurs, relay contacts K6a apply 120 volts a-c to solenoid K7, which releases the latching mechanism of mode switch S5, removing power from the amplifier. Since the OFF section of S5 also remains "out," the blower (controlled by the "out" contact of S5h) continues to operate. Also, when S5h is "out" but power relay K1 remains open as after a plate overcurrent trip-out, lamp I4 illuminates the OFF button red, as a warning.
13. MULTIMETER: Multimeter M2 is switched by S4 to indicate high voltage (HV), grid current (GRID), and r-f power, forward (FWD) or reflected (REFL). Generation of the latter three functions has been previously described. HV metering is forthright, employing a 5 megohm meter multiplier, of 1% accuracy, directly from the +HV power supply point. Resistor R9, connected between multiplier R8 and ground, simply serves to complete the circuit and prevent full high voltage from appearing at the meter switch when metering other than HV.
14. MISCELLANEOUS: Diode D2 serves as a return path for possible HV faults to ground, insuring activation of K6-K7 and protecting M1 and the bias supply. L17-C47-C48 provides thorough r-f and l-f decoupling of the -HV line in the interest of stability. Lamps I9 through I12 illuminate M1 and M2 whenever K9 is closed (time delay completed and grid overcurrent relay not tripped). Pushbutton lamps are controlled by their respective switches and powered by the +28v buss (meter) and 120 vac (mode).

## SECTION 6

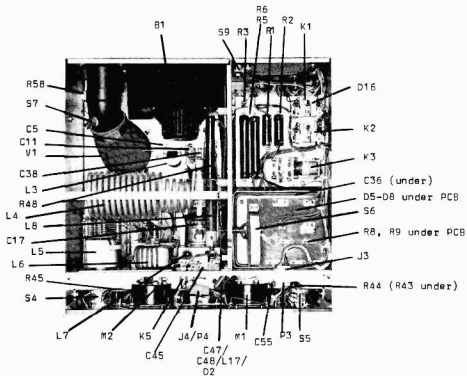
ILLUSTRATIONSFigure 6-1; TOP VIEW

Figure 6-2: BOTTOM VIEW

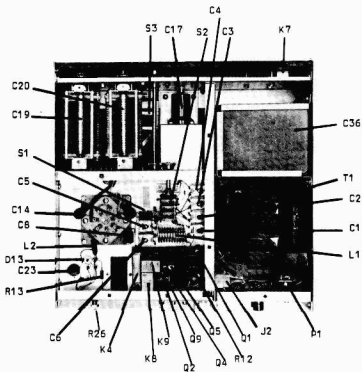


Figure 6-3:  
REMOVAL OF POWER SUPPLY

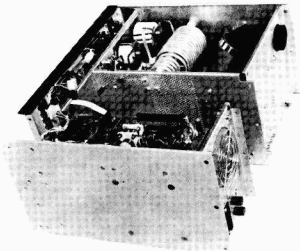
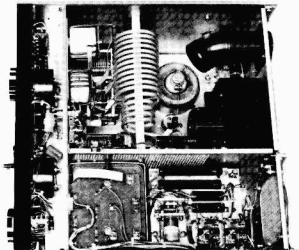
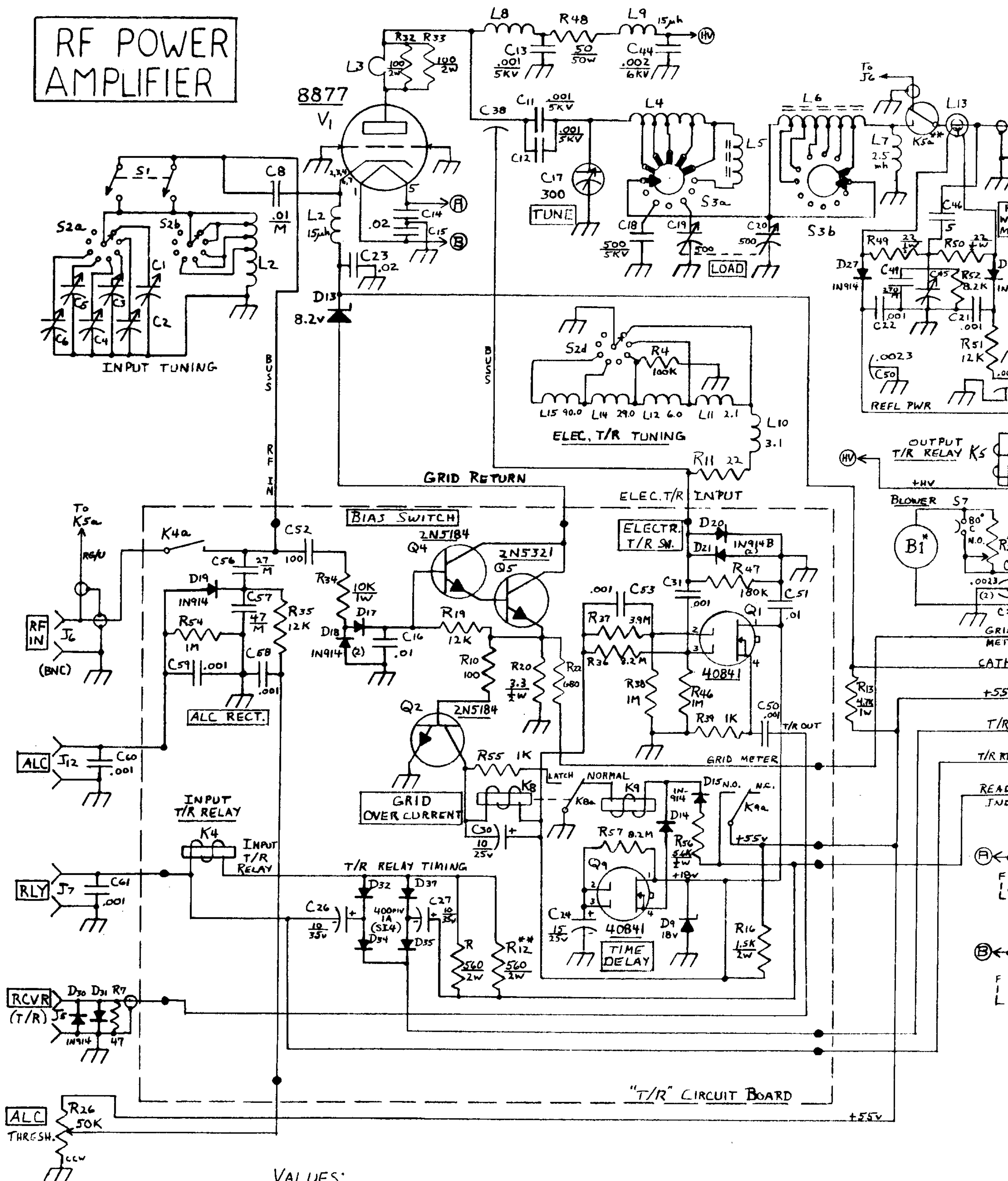


Figure 6-4:  
TOP VIEW WITH  
WARM AIR EXHAUST  
HOOD REMOVED





# RF POWER AMPLIFIER

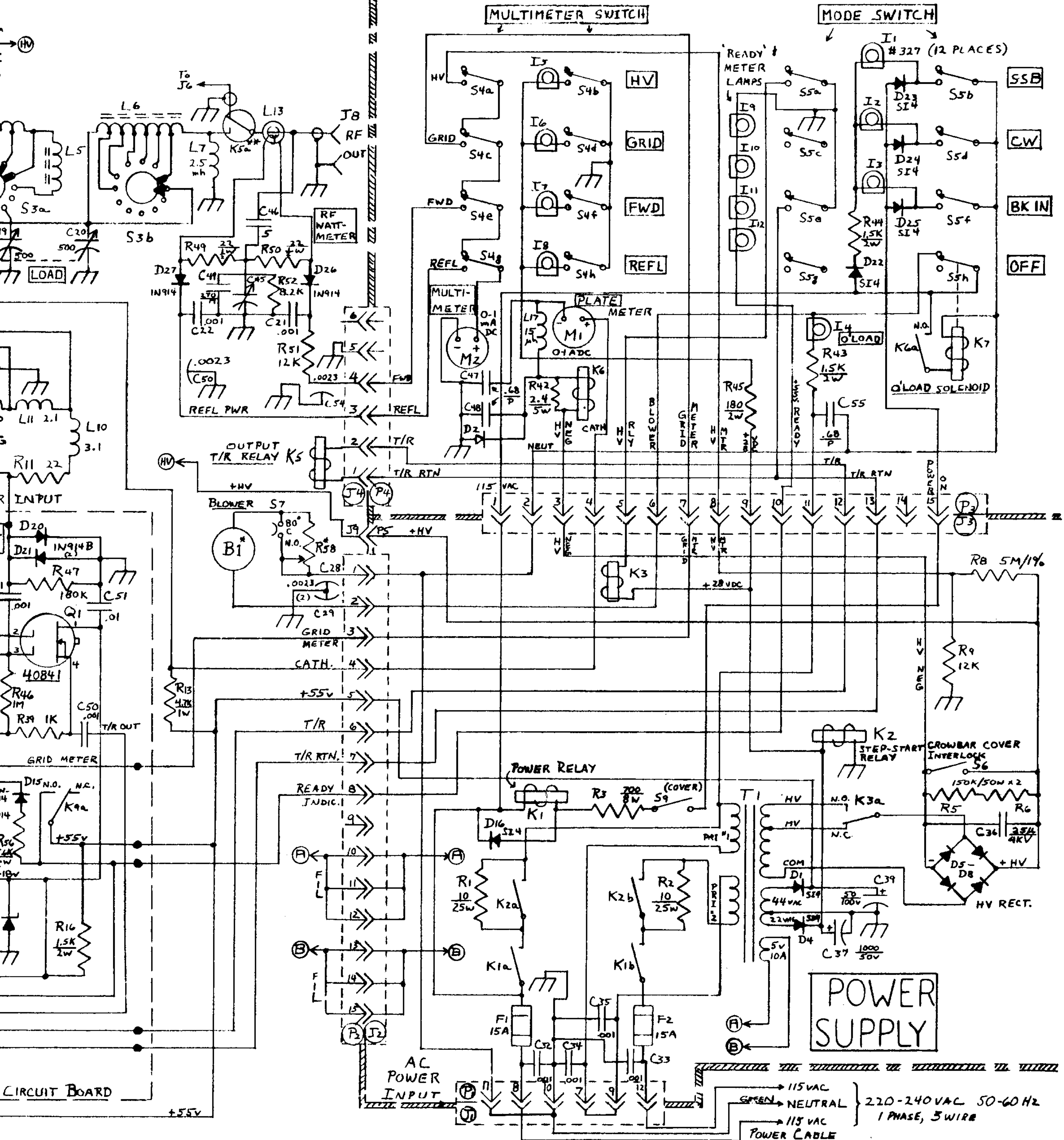


## VALUES:

1. ALL R's OHMS, EXCEPT K= Kilohms, M= MEGOHMS.
2. ALL WHOLE NUMBER C's pf, EXCEPT  $\mu = \mu\text{fd}$ .
- " DECIMAL C's  $\mu\text{fd}$ .
- 3 ALL L's  $\mu\text{H}$  UNLESS NOTED.

BANDSWITCH SHOWN IN FULLY CLOCKWISE (24-30 MHz) POSITION

# CONTROL PANEL



## EHRHORN TECHNOLOGICAL OPERATIONS, INC.

ENGINEER	DRWG NO.	SIZE
DESIGNER	PA-77 SCHEMATIC	
DRAFTING	TITLE:	
APPROVED 10/72 <i>[Signature]</i>	ALPHA 77	
<del>REVISIONS</del> REVISED:	CIRCUIT DIAGRAM	
SCALE:	SHEET OF	PAGE 22

EGOHMS.  
mfd.

(30 MHz) POSITION



# **K4XL's** **BAMA**

This manual is provided **FREE OF CHARGE** from the "BoatAnchor Manual Archive" as a service to the Boatanchor community.

It was uploaded by someone who wanted to help you repair and maintain your equipment.

If you paid anyone other than BAMA for this manual, you paid someone who is making a profit from the free labor of others without asking their permission.

You may pass on copies of this manual to anyone who needs it. But do it without charge.

Thousands of files are available without charge from BAMA. Visit us at <http://bama.sbc.edu>