

OPERATING AND TECHNICAL MANUAL

HIGH FREQUENCY LINEAR POWER AMPLIFIERS

MODELS PA-76, PA-76P, and PA-76C



EHRHORN TECHNOLOGICAL OPERATIONS, INC.

Revised May 1, 1977

TABLE OF CONTENTS

SECTION 1 - General Description and Specifications . . .	1
SECTION 2 - INSTALLATION	2
High Voltage Tap Selection	3
Interconnections With Other Equipment . . .	4
SECTION 3 - OPERATION	5
Initial Tune-Up	6
Operation At 1 KW and 2 KW Input	7
ALPHA 76P and ALPHA 76C Operating Differences	8
Operating Notes	9
Troubleshooting Hints	10
SECTION 4 - THEORY OF OPERATION	11
SECTION 5 - ILLUSTRATIONS	13
Transformer Installation or Removal	13
Rear View	13
Top View Showing Major Component Locations .	14
Schematic Diagram	15
Front Panel View	Front Cover
SECTION 6 - STANDARD ELECTRICAL PARTS	16
ETO/"ALPHA" PRODUCTS WARRANTY	Back Cover

EHRHORN TECHNOLOGICAL OPERATIONS, INC.
CANON CITY, COLORADO 81212
5/77 U.S.A.

SECTION 1

GENERAL DESCRIPTION

The ALPHA 76 (model PA-76) is a self-contained high frequency linear power amplifier capable of continuous operation at d-c plate power inputs of 2.5 kilowatts PEP for SSB voice and one kilowatt average or continuous carrier with no time limit (NTL). The ALPHA 76 is tunable over the range 1.8-2.0 MHz plus 3-30 MHz, optimized for convenience in the six amateur bands of 10 through 160 meters.

SPECIFICATIONS (Model PA-76)

Frequency Coverage: 1.8-2.0 and 3-30 MHz (including 10-160 meters).

Plate Power Input: 2.5 KW PEP/SSB, 1 KW average or key down, CCS.

RF Power Output: Typically 1.5 KW PEP/SSB, 650 watts carrier, CCS.

Drive Power: Nominal 100 watts PEP, 60 watts carrier.

Input & Output Impedances: Nominal 50 ohms resistive, unbalanced; VSWR 2:1 or less.

Distortion: Third order IM more than 30 db below 1 KW PEP output.

Harmonics: More than 50 db below mean fundamental frequency output.

Tube Complement: Two Eimac 8874 ceramic-metal grounded-grid triodes.

Cooling: Full-cabinet, ducted forced air; centrifugal blower.

ALC: Adjustable threshold, negative-going standard as shipped.

Protection: Primary fuses, plate overcurrent relay, AC and HV interlocks.

Primary Power: 240V/10A or 120V/20A, nominal, 50-60 Hz.

Size and Weight: 7.5"h. x 17"w. x 14.75"d. Shipping wt., 75 lb.

Optional Modifications Available:

- Option "L" -- Lightweight Hipersil[®] power transformer reduces net and shipping weights by approximately 20 lb.
- Option "R" -- HI/LO (or "SSB/CW-TUNE") tap change relay, front panel controlled.
- Model 76P -- Identical with PA-76 above except tube complement is three 8874's, increasing plate power input rating to 3+ KW PEP and typical rf output to 2 KW PEP. Does not affect long term average or continuous power ratings.
- Model 76C -- "Commercial" model identical with PA-76 except tube complement is three 8874's, power transformer is special 2.4 KVA Hipersil[®], and option "R" is standard. PEP ratings, d-c input 3 KW, typical rf output 2 KW; continuous carrier or long-term average ratings, d-c input 1.6 KW, rf output 1 KW CCS (RATT, AØ, etc.)

SECTION 2

INSTALLATION

1. Unpacking: Carefully remove amplifier and transformer from cartons; SAVE ALL PACKING MATERIAL FOR RE-USE - SHIPMENT OF THE ALPHA 76 IN OTHER THAN FACTORY PACKING MAY RESULT IN DAMAGE NOT COVERED UNDER WARRANTY.

Inspect closely for evidence of shipping damage; if any is found, notify delivering carrier and seller at once. Complete warranty registration form and mail to ETO.

2. Transformer Installation: The top cover and the right-hand end panel assembly of the amplifier are easily removed for transformer installation. Remove the six flat head Phillips screws from the top and two pan head screws from the rear flange of the top cover, and lift it off.

To remove the right-hand side panel assembly, remove the two flat head screws at the right edge of the front panel, two at the edge of the rear panel, and three pan head screws at the edge of the bottom plate. Pull the end panel assembly straight away from the main chassis assembly.

Orient the transformer so that the two multi-pin, molded plugs on the transformer harness point toward the front of the amplifier; move the corresponding mating connectors in the amplifier itself temporarily out of the way (it may be necessary to tape or tie one or both of them out of the way while installing the transformer). Carefully slide the transformer into position so that the $\frac{1}{4}$ -20 tapped mounting holes in its base line up with corresponding holes in the amplifier base plate. Install the $\frac{1}{4}$ -20 bolts and washers provided through the bottom plate, and tighten securely.

Check both pairs of connectors visually for proper mating orientation (avoid excessive harness bending or twisting, as it may cause damage to wires or connector pins) and mate them firmly, pushing until the integral latches engage.

3. Electrical Installation: If the amplifier is to be used with the type of a-c mains arrangement for which it has been factory-wired (220-250V, 50-60 Hz, 1 phase, unless otherwise specified) the end panel and top cover may be replaced. If change-over to 110-125V power is necessary, make the following changes first:

Change-Over to 110-125V Operation - (The amplifier will operate normally on 110-125V, 50-60 Hz power if the primary supply circuit is of adequate capacity to deliver the required current with reasonable regulation (approximately 20 amps peak, 5-10 amps average at full power, except PA-76C up to 15 amps average). To change from 220-250V to 110-125V operation:

- (a) Locate R4 (2000 ohm/12 watt resistor mounted just above the RELAY jack on the rear panel); install a short jumper of #22 or larger wire across its lugs, shorting it out.
- (b) Locate the 9 pin transformer plug P2. The transformer lead wire originally in the pin 3 position of P2 must be moved to the pin 2 position in the molded shell; also, the lead originally in the pin 6 position must be moved to the pin 5 hole. CAUTION! DO NOT ATTEMPT TO REMOVE THE CRIMPED-ON PINS FROM THE PLUG WITHOUT AN APPROPRIATE EXTRACTION TOOL AS DAMAGE TO

PINS OR CONNECTOR IS ALMOST CERTAIN TO RESULT. On request, ETO will supply at no charge extra push-in pins with short leads attached. Once the amplifier is changed over for 110-125 volt operation, it is strongly urged that a conspicuous label or tag be attached to the power cable to avoid accidental connection to 220-250 volt lines later on.

Power Cable Connection - The green wire of the amplifier power cable is a chassis safety ground, and must always (and only) be connected to the safety ground of the a-c mains -- NEVER to one of the "hot" power wires. The black and white wires are interchangeable and should be connected to the two "hot" conductors of the service.

4. High Voltage Tap Selection: If your amplifier does not contain the high voltage tap change relay with a front panel HI/LO switch, it was shipped from the factory with the internal HV tap connected for full power SSB operation. This connection is also suitable for keyed CW and for intermittent duty FSK or SSTV operation at up to one kilowatt d-c input. For continuous or otherwise heavy-duty carrier operation, slightly higher efficiency and cooler operation may be achieved by moving the internal tap to the medium voltage (MV) position, as follows:
- (a) DISCONNECT A-C POWER; remove amplifier top cover; short crowbar.
 - (b) On HV & control circuit board located at right, front of the chassis, note short loop of blue HV wire terminated in a female quick-connect (QC) lug. For normal high voltage SSB operation this blue wire is mated with another blue HV wire from the main wiring harness ... via the rear-most double male QC lug on the circuit board. To connect instead the medium voltage tap, remove only the female QC lug connected to the short blue jumper wire and push it fully on to the front-most male QC lug (which is already also connected to a green HV wire from the harness). No-load plate voltage will thereby be reduced from 2.4 KV (HI) to approximately 1.6 KV (LO).

It is desirable that you familiarize yourself with amplifier operation, and perform initial tune-up, using the "LO" tap. A chart of TUNE and LOAD control settings determined under these conditions will then permit presetting the controls very closely when changing frequency thereafter, requiring only minor touch-up in operation.

NOTE: Use of the optional HV tap change relay permits convenient (and on-the-air legal) tune-up at one kilowatt input; switching then to the HI position prepares the amplifier instantly for full power SSB operation at 2+ KW. PEP input -- without further adjustment.

5. Physical Location: The ALPHA 76 must be located so that intake of cool air through the rear panel, and exhaust of hot air through the top cover perforations, is not impeded in any way. A minimum of 4 to 6 inches of clearance should be allowed behind and above the amplifier cabinet for air circulation. Be careful not to block the top-cover exhaust openings with log books or equipment.

6. RF And Control Connections: Interconnection of the ALPHA 76 for operation with any popular transceiver or exciter is extremely simple. Connect the rear panel jacks as follows:

RF INPUT - Use a standard "RCA" type plug and RG-58C/U or similar small 50 ohm coaxial cable to connect to transceiver or exciter "rf output" or "antenna" connector. Keep cable short if possible.

RF OUTPUT - Use a standard PL-259 ("UHF" type) plug and RG-8A/U or similar 50 ohm coaxial cable to connect to antenna system.

RELAY - Use a standard "phono-type" patch cable to connect this jack to contacts which are "open" on receive and "shorted" on transmit ("N.O." -- normally open). Such contacts are usually available on the rear panel of the exciter or transceiver in the form of a matching "phono" connector. A few transceivers, such as Atlas and Drake units, may require special connectors for tying into their internal transmit-receive relay contacts.

NOTE: When the amplifier is OFF or in the RECEIVE condition with no short across the RELAY line, the RF OUTPUT connector is internally connected directly to the RF INPUT connector, providing normal "transceive-type" antenna input to the receiver.

ALC - For use with conventional transceivers having negative-going ALC systems, simply patch this jack to the mating ALC jack on the transceiver (or exciter), using standard "phono" cable. Certain solid-state transceivers utilize positive-going ALC which requires slight modification of the amplifier's ALC circuit, or use of an adapter, if ALC feedback is to be employed. Normally it is quite satisfactory to simply use the transceiver's internal ALC system with Atlas, Triton, and similar radios.

SECTION 3

OPERATION

1. Control Functions:

BAND - Selects tuning range of amplifier, indicating the nominal center of the range in MHz.

TUNE - Controls amplifier resonant frequency. In general, higher frequency bands (28 & 21 MHz, etc.) tune nearer to the "0" end of the vernier dial scale, while lower-frequency bands (3.5 and 1.8 MHz) tune more in the 50 to 100 range.

LOAD - Controls degree of amplifier loading. Higher bands (28 & 21 MHz) load properly toward the 70-100 end of the vernier dial scale, lower bands more in the 0-50 range. In general, adjusting toward a higher number results in a heavier loading of the amplifier.

ON/OFF - Controls main a-c power to amplifier. Also serves as "reset" control after power turn-off by overcurrent relay.

HI/LO - (Optional on PA-76 and PA-76P, standard on PA-76C) Selects "high" or "medium" HV tap for SSB or CW/TUNE/FSK/SSTV operation, respectively.

PUSH BUTTONS -

STBY: Disables amplifier changeover relay, thereby permitting "straight-through" operation of exciter/transceiver while amplifier remains ready for use. Meter monitors amplifier high voltage (HV: 3 KV full scale).

OPERATE-HV (2nd button): Permits normal operation of amplifier while meter monitors HV.

GRID: Normal operation, meter monitors grid current (150 milliamperes full scale).

PLATE: Normal operation, meter monitors plate current (1.5 amperes full scale).

FWD: Normal operation, meter monitors rf forward power (2000 watts full scale).

REFL: Normal operation, meter monitors rf reflected power (200 watts full scale) for determining load VSWR.

ALC (rear panel adjustment) - Sets drive power level at which ALC voltage begins to rise from zero; sets "ALC threshold."

2. Tune-Up Procedure:

(a) GENERAL - The end goal of tune-up is to adjust the amplifier for maximum power output at the intended/desired level of drive power and d-c plate input. If a steady carrier at a fixed power level is applied to the RF INPUT and the ALPHA 76 TUNE and LOAD controls are properly adjusted to yield the maximum available rf power output, the amplifier is automatically set up properly for the best combination of efficiency and linearity possible at that drive level.

If the drive power is increased beyond the tune-up level after the final TUNE/LOAD adjustments, flattopping and undesirable distortion (on SSB) will result, along with grid current greatly in excess of normal.

If drive power is reduced below the tune-up level without further adjustment of TUNE and LOAD controls, amplifier efficiency will be reduced. Both of these statements are applicable to any linear amplifier of the types used for high power amateur and similar service.

It is therefore essential that the amplifier be adjusted for maximum rf output at the drive and d-c input powers which are to be employed in normal operation, WITH ONE IMPORTANT EXCEPTION: if the plate voltage is changed without changing also the TUNE and LOAD adjustments, the resulting power level which will yield optimum performance at the new plate voltage will vary in proportion to the square of the plate voltage change. For example, if the ALPHA 76 is tuned up for maximum output with 1400 VDC plate voltage and with the drive level set so that the resultant maximum output is about 700 watts (equivalent to a d-c input of roughly 1000 watts), THEN if the plate voltage is increased to 2000 VDC the amplifier will automatically perform optimally at about $700 \times (2000/1400)^2 = 1400$ watts rf output, corresponding to approximately 2000 watts d-c input.

In general, the final operating adjustment after basic tune-up should be to adjust excitation (drive) from the exciter or transceiver so that the GRID current meter indication just reaches about 50 macd (1/3 scale) key-down or on voice peaks.

(b) INITIAL TUNE-UP - Select medium plate voltage by either placing the panel switch controlling the (optional) HV tap change relay into its LO (down) position or selecting the internal MV tap before installing the amplifier cover during installation. Make certain that the top cover is properly fastened in place.

(1) Press STBY button and momentarily lift the ON toggle. The panel meter should immediately illuminate red or amber and indicate 1.5 KV (mid-scale) + 100 V. The blower should start immediately and exhaust air should be readily detectable flowing from the top cover vents.

(2) When the tube warm-up delay is completed in 45 to 90 seconds, the meter will change from amber to pale green, indicating "ready" to transmit. Set controls to the preliminary points indicated in Table I below, depending on the desired operating frequency.

TABLE I -- PRELIMINARY SETTINGS FOR INITIAL TUNE-UP

<u>FREQ., MHZ</u>	<u>BAND</u>	<u>TUNE</u>	<u>LOAD</u>	<u>FREQ.</u>	<u>BAND</u>	<u>TUNE</u>	<u>LOAD</u>
1.8	1.8	84	30	7.1	7	50	45
2.0	1.8	75	25	14.15	14	21	70
3.6	3.5	53	38	21.20	21	10	82
3.9	3.5	42	48	28.70	28	08	85

(3) Press PLATE button and switch exciter to CW or TUNE; the panel meter should turn amber to indicate 'transmit.'

- (4) Very slowly increase exciter carrier output until the amplifier panel meter indicates plate current of 0.5 amps (1/3 scale). Press FWD button and carefully adjust LOAD control for maximum meter indication. Then adjust TUNE for maximum meter reading, and repeat the process of alternately adjusting first LOAD, then TUNE, until no further increase in FWD power is obtainable.
 - (5) Press PLATE button and note meter indication; the desired reading for one kilowatt d-c input is approximately 0.7 amp (since 0.7 amp X 1400 volts = 980 watts input).
 - (6) If the plate current in step (5) was less than 0.7 amp, increase exciter carrier output slightly and repeat the LOAD/TUNE adjustment process of steps (4) and (5) again. If the plate current in step (5) is greater than 0.7 amp, decrease exciter output slightly and repeat the LOAD/TUNE process of steps (4) and (5) again.
 - (7) Continue making slight corrections in drive power, and then adjusting LOAD and TUNE alternately for maximum FWD power output until, after the final adjustment, the PLATE current meter indication is very close to 0.7 amp.
 - (8) The ALPHA 76 is now correctly adjusted for operation at one kilowatt d-c input using the medium plate voltage tap.
- (c) OPERATION AT 1 KW INPUT (KEY-DOWN OR PEP) - Tune up as in (b) just above. Leave amplifier in medium ('LO') plate voltage condition. Check exciter rf output (mike gain, cw level, or rf output control, as applicable) to insure that key-down amplifier GRID current reading is about 50-75 ma (1/3 to 1/2 scale). On SSB set mike gain or exciter rf output level so that GRID current reading on speech peaks does not exceed 40-50 ma (less than 1/3 scale).
- (d) OPERATION ON SSB AT 2+ KW PEP INPUT - Tune up exactly as in (b) above. Remove excitation. Switch (optional) HV tap-change relay to 'HI' position if available; otherwise remove all power from amplifier, open top cover, and change over to high voltage tap position as described on page 3, paragraph 4 (blue-to-blue wires). Replace cover, reconnect a-c power, and switch ALPHA 76 ON.

When meter lights green, switch exciter to SSB and speak normally into the mike while adjusting mike gain (or rf output) control so that highest meter swings with the PLATE button depressed reach approximately 0.45 amp (just under 1/3 of full scale), OR until highest GRID current swings reach 50 ma (1/3 scale), whichever occurs first.

Maximum (U.S.) amateur power input of one kilowatt average corresponds to highest PLATE meter swings of about 0.45 amp, as described above, provided that plate voltage (HV) drops to approximately 2.2 KV on speech peaks. Depending on individual voice and exciter characteristics, it may be desirable to initially adjust for loading slightly lighter (or heavier) than described above so that SSB speech peaks of 0.45 amps PLATE and 30-50 ma GRID current occur simultaneously.

(e) TUNE-UP UNDER "HV" CONDITIONS - When the optional HV tap change relay is not included, the ALPHA 76 may safely be tuned-up with maximum plate voltage applied so that the internal taps need not be changed. Extra care must be exercised, to avoid abusing the amplifier or tubes, to insure that (a) drive power is kept low and adjusted very carefully, with LOAD adjusted first and TUNE second at each step and that (b) PLATE current is not permitted to exceed 0.7 amp for longer than 15-20 seconds at a time, nor 1.0 amp at any time.

(1) For One Kilowatt Input With HI Plate Voltage, follow the same basic procedure as described in steps (4) through (7) except make all adjustments for a final "target" PLATE current of approximately 0.45 amp (X approx. 2.2 KV = 1000 watts input). (Reference: page 7.)

(2) For 2+ KW PEP SSB Operation, tune up in HV just as in steps (4) through (7) on page 7 for LO voltage tune-up except the final plate current goal is 1.0 amp at the end of the last LOAD/TUNE adjustment iteration. (NOT LEGAL ON ANTENNA!)

ALWAYS ADJUST LOAD CONTROL FIRST, THEN TUNE! Vary the excitation in small steps, as necessary, until the desired plate current is achieved at maximum output. Then switch exciter/transceiver to SSB and adjust mike gain as described on page 7.

NOTE! When operating at one kilowatt carrier or PEP input in the HI plate voltage condition, the maximum drive power required is only about 50 watts, typically. Severe overdrive may result in serious damage to tubes or rf tuning circuits which may not be covered by warranty.

3. ALPHA 76P and ALPHA 76C Operating Differences:

(a) Plate current values referred to in previous pages in connection with tune-up and operation of the ALPHA 76 may generally be increased by 40-50% for the three tube "P" and "C" models; corresponding grid currents will typically increase 40-50% as well. This allows both the 76P and the 76C to operate at 40-50% higher levels of peak or intermittent power input and output.

(b) The extra-duty 2.4 KVA Hipersil[®] power transformer used in model ALPHA 76C permits this model to operate at a long-term average or continuous power level approximately 50-60% greater than that of the ALPHA 76 or 76P -- about 1.5-1.6 KW d-c input and 1 KW rf output, continuous duty, versus 1.0 KW d-c input maximum (continuous or average) for the 76 and 76P.

(c) Extra caution is required in using the ALPHA 76F to guard against accidentally exceeding the long-term/CCS average d-c input rating of 1 KW. This normally is not a problem except possibly in the event of continuous key-down operation or continuous SSB transmission with heavy speech processing.

(c) PA-76C employs 15 amp, type 3AB or ABC fuses. With all models, 20 amp 3AB or ABC fuses may be substituted for 120V operation.

4. Operating Notes:

- (a) TUBES - The 8874 ceramic triodes are extremely rugged and normally operate with a large margin of safety. They will deliver outstanding service life IF not damaged by grossly excessive grid dissipation or airflow blockage (keep the intake and exhaust vent areas clear!) Do not allow average plate current per tube to exceed 0.35 amp for more than 15-30 seconds, nor ever to exceed 0.5 amp. Do not allow grid current to ever exceed full scale (150 ma); normal operation requires only 50-60 ma.
- (b) INTERLOCKS - The ALPHA 76 (all versions) is equipped with switches which shut off a-c power and short out the high voltage power supply when the cover is not securely fastened in place. THESE PROTECTIVE INTERLOCKS ARE PROVIDED TO PROTECT YOU AGAINST POTENTIALLY FATAL ELECTRIC SHOCK RESULTING FROM CONTACT WITH OPERATING VOLTAGES INSIDE THE AMPLIFIER. THE AMPLIFIER SHOULD NEVER BE ENERGIZED WITH THE COVER REMOVED AND INTERLOCKS DEFEATED EXCEPT BY THOROUGHLY TRAINED AND KNOWLEDGABLE SERVICE PERSONNEL!
- (c) FUSES - Except in rare instances of component failure, the blowing of one or both primary line fuses indicates that the maximum safe average power input capability of the amplifier has been substantially exceeded. DO NOT SUBSTITUTE OVERSIZED FUSES except as noted on the previous page.

The slo-blo fuse F3 located just behind the front panel prevents burn-out of the step-start resistors and HV rectifiers in the event of abnormal turn-on conditions or HV faults. DO NOT SUBSTITUTE a fuse of different type or rating.

- (d) PLATE OVERCURRENT RELAY - This relay functions primarily to de-energize the primary power quickly in the event of a fault in the HV circuitry or grossly excessive drive conditions. The relay should not be relied on to prevent either short- or long-term overdrive; that is the operator's responsibility. Should the overcurrent relay trip, removing all a-c power from the amplifier, it is essential to determine and correct the cause before re-applying power by actuating the ON toggle.
- (e) MAINTENANCE AND TROUBLESHOOTING - Most apparent failures and problems with the ALPHA 76 series result from operators' failure to read and thoroughly understand the contents of this manual, as well as basic linear amplifier principles -- rather than from actual equipment defects.

Amplifier interiors, particularly the high voltage d-c areas of the power supply and rf compartment, should be cleaned frequently enough (with a soft brush and a vacuum cleaner) to prevent visible accumulation of dust. If extremely dusty conditions prevail, it may be advisable to secure a thin plastic air filter, of the type used in window air conditioners, across the air intake area.

TABLE II -- TROUBLESHOOTING HINTS

<u>SYMPTOMS</u>	<u>POSSIBLE CAUSE/CURE</u>
1. Won't turn on; nothing happens when ON toggle lifted.	a) External a-c wire, fuse, or breaker open or missing. b) Cover a-c interlock open. c) Fuse F1 or F2 blown or missing.
2. Relay closes (and blower may start) but no HV or meter illumination at turn-on.	a) Step-start relay K2 not closing; possible blown fuse F3, defective +28V supply (D13-D-14 or C7?), or HV fault.
3. Blower starts, HV normal, but meter does not switch to green and amplifier will not switch to transmit.	a) Defective reed relay K6. b) Defective Q1, C8, or R29.
4. Grid meter "pins" at low drive levels	a) R28 open or damaged.
5. Low grid current, excessive input VSWR (abnormal exciter loading), low rf output.	a) Bias zener D8 damaged or open. b) R28 damaged or open (but grid current will read very high).
6. Plate current flows in receive or STBY conditions. See also no. 9 below.	a) 8874 tube leak or short, cathode to grid or heater. b) D7 defective or damaged.
7. Low drive and output power; cannot drive exciter to normal input or output levels.	a) ALC sensitivity control R40 set improperly; unplug ALC to check. See note bottom of pg.
8. Flashover in RF compartment, usually between load capacitor plates.	a) Excessive load VSWR; mismatch or wrong antenna; defective rf cables or connectors. b) Insufficiently heavy loading and/or excessive drive power. c) Dirt or other contaminant in capacitor plates. d) If chronic, capacitor plates damaged by previous arcing.
9. Plate current flows in receive or STBY <u>and</u> cannot drive amplifier; abnormal exciter loading.	a) 8874 tube short, cathode-to-grid or cathode-to-heater.
10. Distorted SSB output signal; possibly severe TVI.	a) Excessive drive power and/or inadequately-heavy loading. b) Flashover of variable capacitor on voice peaks. c) Antenna or feedline arcing on peaks. d) RF feedback from antenna into exciter or microphone line.

NOTE: If exciter manufacturer does not provide instructions for adjustment of ALC, set pot R40 for desired amplifier plate current swings on peaks and adjust mike gain for degree of ALC action desired for normal exciter operation.

SECTION 4

THEORY OF OPERATION

1. RF Amplifier Section: Tubes V1 and V2 (and V3 in models 76P and 76C) are parallel-connected in a grounded grid configuration. +28 volts of cathode bias is applied via R7 and L7 to cut off plate current during non-transmit periods; bias is reduced to an operating level of 5.1 volts when the antenna relay is actuated.

RF excitation is applied to the cathodes via a broadband, toroidal ferrite matching transformer, T2. Resistor networks R17 and (in standard model 76 only) R22 establish a nominal drive power requirement of 100 watts PEP and help provide a 50 ohm input impedance.

The plate output circuit is a full pi-L network consisting of C16, L1-L2-L3, C17, and L4. The pi-L provides harmonic suppression substantially better than a simple pi network, as well as somewhat better efficiency in this application.

An rf directional wattmeter, consisting of L9 and associated components, senses forward and reflected power in the rf output line for display on the panel meter when selected by push-buttons FWD and REFL, respectively.

Excitation voltage is detected and filtered by ALC rectifier C23-C24, D15, and associated components. The drive level at which negative-going ALC is generated (i.e., the threshold level) is set by rear-panel potentiometer R40 which back-biases D15.

Relay K4 switches the antenna straight through to the exciter when the amplifier is OFF or in STBY or receive conditions, permitting normal transceive operation. K4 switches the ALPHA 76 into the transmit configuration when an external short is placed across RELAY control jack, J3.

2. Power Supply: Transformer T1 is a 1.5 KVA continuous-service unit (2.4 KVA Hipersil[®] core in PA-76C only) which supplies all required a-c operating voltages for the amplifier.

High voltage d-c for the tube anodes is rectified by a full-wave bridge, D1-D4, and filtered by a 30 mfd., 2.7 KV capacitor consisting of C1-C6 in series. These computer-grade electrolytic capacitors are factory capacitance-matched to insure uniform a-c ripple voltage distribution and long service life.

High voltage may be reduced from the normal SSB value of 2.2-2.4 KV to approximately 1.4-1.6 KV by taking the HV rectifier input from an alternate transformer tap. A high voltage tap-change relay, K3 (standard in PA-76C, optional in other models), controlled by HI/LO toggle switch S6, permits making this selection from the front panel. In units without the HV relay, the selection is made with quick-connect lugs on the HV circuit board.

Cover interlock switch S4 prevents actuation of main power relay K1 unless the top cover is secured in place. Safety "crowbar" S5 places a low-resistance short across the HV supply (and discharges the filter capacitors) whenever the cover is open.

FWCT rectifier D13-D14, and filter capacitor C7, provide +28 V for bias and control circuitry. A 25 VAC transformer winding is "bucking" connected to provide approximately 95 VAC for the blower, resulting in a reduced noise level but virtually the same air delivery as at full voltage.

Dual primary windings on T1 permit connection for either 110-125 V or 220-250 V operation, as described in the Installation section of this manual. No wiring change is necessary for operation from either U.S. standard 120-N-120 or from typical overseas 220-250 V without "central" neutral -- two-wire systems. The third power cable (green) wire is simply a chassis safety ground.

3. Control And Metering Circuits: ON/OFF toggle switch S2 controls self-latching main power relay K1. Resistors R1 and R2 limit the initial current inrush to 12 amperes maximum, and are shorted by relay K2 when the HV filter capacitor approaches full charge (the delay is only a few tens of milliseconds). Fuse F3 protects against burn-out of R1 and/or R2 in the event of mistakes or faults which prevent K2 from closing properly.

During the required heater warm-up period, the 8874 tubes are protected against plate current flow by a 60-second (nominal) time delay circuit consisting of MOSFET Q1 and associated components. Until C8 reaches sufficient voltage to close K6 via Q1, T/R relay K4 is prevented from closing regardless of external RELAY line conditions. Hence, standby (cut-off) tube bias is maintained and rf drive cannot be applied to the tubes.

After time delay K6 closes, an external short across J3 (the RELAY control jack) closes T/R relay K4, provided that the STBY button of switch S3 is not depressed. This reduces cathode bias applied via R7 to the +5.1 volts determined by zener D8. This operating bias level permits slight plate current flow under idling conditions in the SSB (high voltage) mode; with lower plate voltage applied for CW, tune-up, or other purposes, idling plate current is close to cut off.

Plate current flow is metered across fault-current-limiting resistor R6; R38 calibrates the full-scale meter range. Grid current is similarly measured across R28 in the grid return circuit. High voltage is metered directly via precision multiplier resistors R13-R15.

Excessive plate current (as indicated by abnormal voltage drop across R6) actuates overcurrent relay K7, which trips out K1. Status indicator lamps I1 and I2, which illuminate the multimeter from behind, are controlled by Q2 and Q3 such that amber lamp I2 lights when K6 is open (during the time-delay period) and when the external RELAY line is shorted with the amplifier in OPERATE, so that the T/R relay is in the transmit position. When the time delay relay is closed but the T/R relay is not actuated (amplifier in STBY and/or external RELAY line open), the green lamp lights to signify "ready."

SECTION 5 -- ILLUSTRATIONS

FIGURE 1 - Transformer Installation or Removal

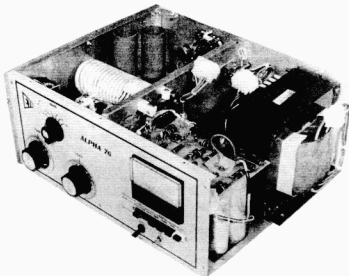

FIGURE 2 - REAR VIEW

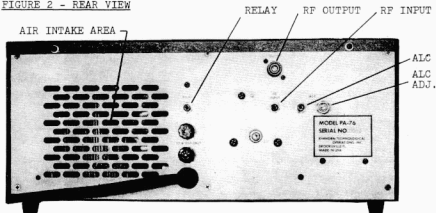
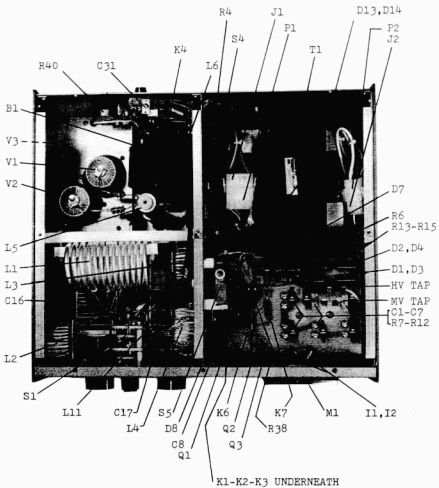
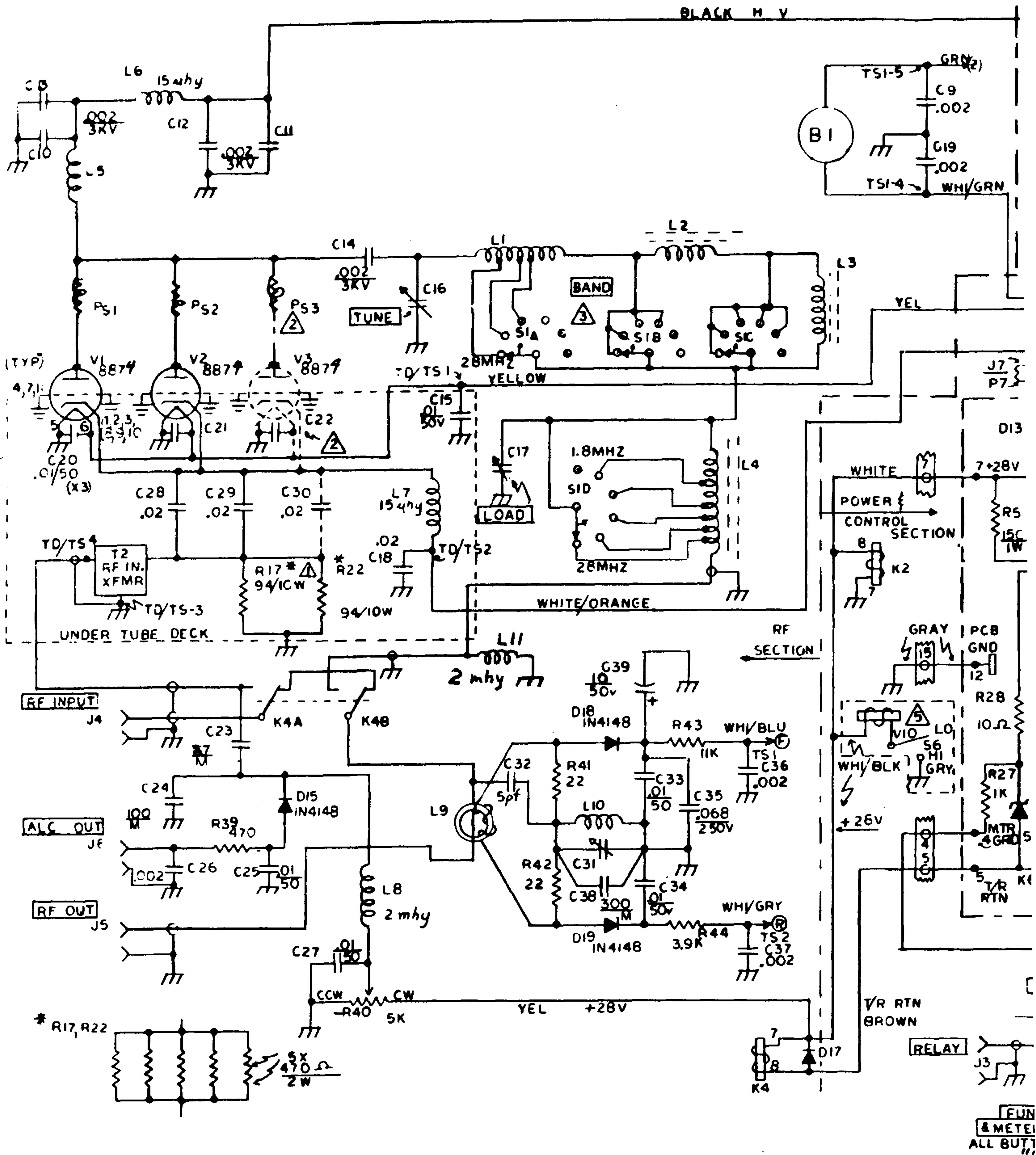

FIGURE 3 - Top View Showing Major Component Locations





NOTES:

- △ R22-5 EACH 470/2W: PA-76 ONLY
- △ PA-76 ONLY (V3 CKTY)
- △ SOME UNITS DIFFER SLIGHTLY
- △ 2K/12W EXCEPT SOME 3K/12W WITH 3.3K PARALLEL, SHORTED FOR 120V ONLY

△ OPTIONAL HV RELAY (K3)

△ XFMR LEAD COLORS APPLY TO STD PA-76 XFMR ONLY; HIPERSIL XFMR WIRE COLORS VARY

7. ALL CAPACITORS 1KV UNLESS NOTED

8. ALL RESISTORS 5 or 10% 1/4W UNLESS NOTED

9. ALL D'S IN4004 UNLESS NOTED

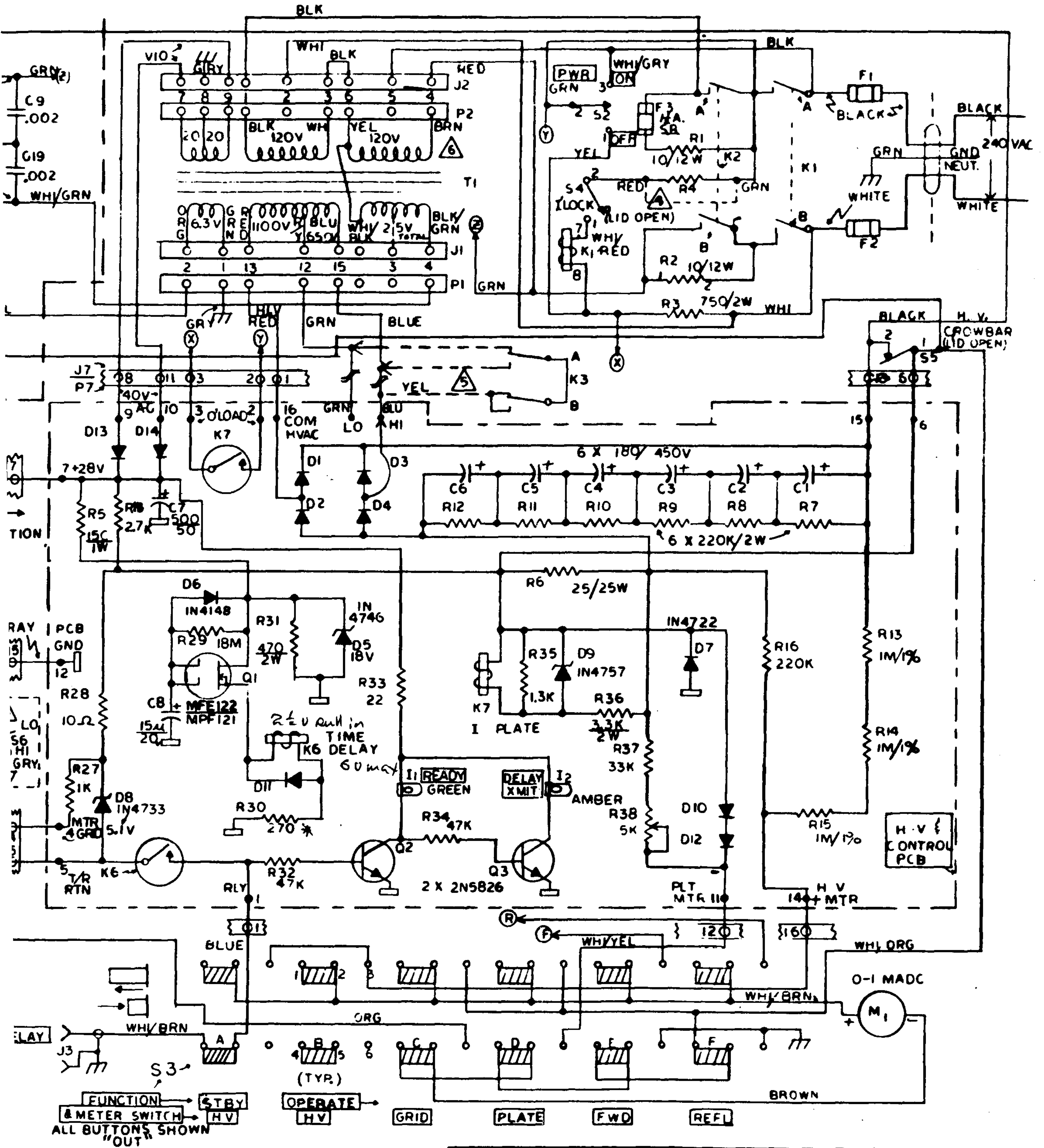

N4004 UNLESS NOTED

EHRHORN TECHNOLOGICAL OPERATIONS, INC.
 Cañon City, Colorado

9/1/76 *10/2* MODELS PA-76 AND 76C & 76P
 DWG NO: SCHEMATIC

SECTION 6 -- STANDARD ELECTRICAL PARTS

<u>SYMBOL</u>	<u>DESCRIPTION</u>	<u>SYMBOL</u>	<u>DESCRIPTION</u>
B1	Howard #3-90-8507	K6	24V form A reed, EAC #1A24AH
C1 - C6	180uf/450V elect.;	K7	5V form A reed, EAC #1A5AH
C7	CDE #FAH-180-450	L5,L6,L7	15uhy/1A rfc
C8	500uf/50V elect.	L8, L11	1 to 2.5 mhf rfc
C9, C19, C26	15uf/20V tantalum	L10	1 mhy miniature
C10-C14,C36,C37	.002uf/1 KV disc	Q1	MFE122, MPF121, or similar dual-gate
C15,C20-22,C25,	.002uf/3 KV disc	Q2, Q3	2N5826
C27,C33,C34	.01uf/50V disc	RESISTORS: All are $\frac{1}{4}$ watt, 5% carbon composition or film of value shown, except as listed below.	
C18,C28-C30	.02/500V disc	R1, R2	10ohm/12W wirewound
C23	27pf dipped SM	R3	750ohm/2W 10% comp.
C24	100pf dipped SM	R4	2K/12W wirewound
C31	100pf, ARCO 423	R5	150ohm/1W 10% comp.
C32	5pf/1KV disc	R6	25ohm/25W wirewound
C35	.068uf/250V film	R7-R12	220K/2W 10% comp.
C38	300pf dipped SM	R13-R15	1M/1% precision film
C39	10uf/50V elect.	R17, R22	Five each 470ohm/2W 10% comp. in parallel
C40		R31	470ohm/2W 10% comp.
D1-D4	3KV PIV/.5A CCS, RCC 1733	R36	3.3K/2W 10% comp.
D5	1N4746 (18V/1W)	R38	5K trimpot, linear
D6,D15,D18,D19	1N4148 or 1N914B	R40	5K linear taper, 1W
D7	1N4722 (400V/3A)	R41	
D8	1N4733 (5.1V/1W)	S1	Centralab JV9034
D9	1N4757 (51V/1W)	S2	SPDT momentary tog.
D10-D14,D17	1N4004 (400V/1A)	S3	6 station pushbutton, Switchcraft type # 65061 K 206 int'lok
D20		S4	Microswitch V3L-4-D8
F1,F2	10A/250V ceramic, type 3AB or ABC (PA-76C, 15A)	S6	SPST 3A toggle
F3	1 $\frac{1}{2}$ A slo-blo, type MDL or equiv.	V1,V2,V3	Eimac type 8874
I1, I2	#387, 28V lamp	ALL ELECTRICAL AND MECHANICAL COMPONENTS NOT LISTED ARE SPECIALLY-FABRICATED AND AVAIL- ABLE FROM ETO; SPECIFY MODEL AND SERIAL NUMBER OF AMPLIFIER PLUS CIRCUIT SYMBOL OR DESCRIP- TION TO ORDER REPLACEMENTS.	
K1	DPST/120VAC, Guardian 900-2C- 120A or 1390-2C- 120A		
K2	DPST/24VDC, Guard- ian 905-2C-24D or 1395-2C-24D		
K3	HV relay, 24VDC, Magnecraft type W158-HVX-1-24V or P-B type PRD11DY0-24		
K4	DPDT/10A,Guardian 905-2C-24D or Phillips 39C11D24		

ETO/"ALPHA" PRODUCTS WARRANTY

EHRHORN TECHNOLOGICAL OPERATIONS, INC. (ETO) WARRANTS AS FOLLOWS EACH NEW ELECTRONIC PRODUCT OF ITS MANUFACTURE:

- (1) Workmanship and all components except rf power tubes are guaranteed for EIGHTEEN MONTHS (VOMAX only, twelve months) from date of original purchase if used exclusively in licensed amateur radio service, and for ninety days if used in non-amateur service.
- (2) Power tubes are warranted by their manufacturer; ETO will assist owners in securing warranty service if requested.
- (3) Warranty does not apply to repair of damage resulting from improper maintenance or repair, misuse, neglect, abuse, or improper installation, nor to units not operated in accordance with specifications and instructions furnished by ETO, nor to units repaired or altered by persons not authorized by ETO, nor in cases where the serial number has been removed, altered, or defaced.
- (4) If a malfunction is suspected, before attempting repairs or returning equipment to ETO for service the owner shall contact selling dealer or factory service department, providing model and serial numbers plus details of equipment hook-up, accessory equipment used, operating conditions, and abnormalities observed. ETO will furnish a new part in exchange for any covered defective part or, if it is determined that factory service is required, will authorize return to factory. Equipment authorized for return shall be shipped fully prepaid and insured via United Parcel or air freight (to Colorado Springs airport only), using only FACTORY APPROVED PACKING; REMOVE POWER TRANSFORMER BEFORE SHIPPING ANY UNIT WHICH WAS ORIGINALLY SHIPPED FROM THE FACTORY WITH TRANSFORMER REMOVED!
- (5) In order to receive warranty service, owner must have returned a completed warranty registration form to ETO within 15 days of original purchase, or must provide proof of purchase date when requesting service. Warranty will be transferred to subsequent owner provided he notifies ETO in writing of his name, address, date of purchase, and the equipment model and serial.
- (6) No person is authorized to assume for ETO any liability, other than as set forth in this warranty, in connection with our products. ETO reserves the right to change its products as it deems desirable, without obligating itself to make such changes available for previously manufactured products.

(UNDER PROVISIONS OF THE FEDERAL MAGNUSON-MOSS WARRANTY ACT, THIS WARRANTY POLICY IS CLASSIFIED AS A LIMITED WARRANTY.)

EHRHORN TECHNOLOGICAL OPERATIONS, INC.

Ehrhorn Technological Operations, Inc.
4975 North 30th Street
Colorado Springs, CO 80919

4/1/77

K4XL's **BAMA**

This manual is provided **FREE OF CHARGE** from the “BoatAnchor Manual Archive” as a service to the Boatanchor community.

It was uploaded by someone who wanted to help you repair and maintain your equipment.

If you paid anyone other than BAMA for this manual, you paid someone who is making a profit from the free labor of others without asking their permission.

You may pass on copies of this manual to anyone who needs it. But do it without charge.

Thousands of files are available without charge from BAMA. Visit us at <http://bama.sbc.edu>