

OPERATING AND TECHNICAL MANUAL

HIGH FREQUENCY LINEAR POWER AMPLIFIER

ALPHA 374A



EHRHORN TECHNOLOGICAL OPERATIONS, INC.

CAÑON CITY, COLORADO 81212

1979

TABLE OF CONTENTS

SECTION 1 - General Description and Specifications . . .	1
SECTION 2 - INSTALLATION	2
Interconnections with other equipment . . .	3
Preparing blower for operation	3
SECTION 3 - OPERATION	4
Bandpass operation	5
Manual tune-up and operation	7
Operating and maintenance notes	8
Troubleshooting hints	9
SECTION 4 - THEORY OF OPERATION	10
SECTION 5 - ILLUSTRATIONS	12
Top view showing major components	12
Rear panel view	13
Enlarged view of RF output network area . .	13
Standard electrical parts list	14
Schematic diagram	15
ETO/"ALPHA" PRODUCTS WARRANTY	Inside Back Cover
FRONT PANEL VIEW, ALPHA 374A	Front Cover

EHRHORN TECHNOLOGICAL OPERATIONS, INC.
~
CAÑON CITY, COLORADO 81212

SECTION 1

GENERAL DESCRIPTION

The ALPHA 374A is a self-contained, high frequency linear power amplifier capable of continuous operation at d-c plate input powers of two kilowatts PEP/SSB and one kilowatt average or continuous carrier, with no time limit. It is manually tunable from 1.8-2.0 plus 3-22 MHz, optimized for convenience in the 160 through 15 meter amateur bands (export models also cover 10 meters).

Four additional bandswitch positions provide NO-TUNE-UP operation at full legal power on the 80-75 through 15 meter amateur bands.

SPECIFICATIONS, MODEL ALPHA 374A:

Frequency Coverage: 1.8-2.0 and 3-22 MHz manually tuned. Amateur bands 3.5-4, 7-7.3, 14-14.35, and 21-21.45 MHz without tune-up when changing bands, using internal, factory-preset tune/load circuitry. A nine-position bandswitch permits selection of any desired manual or no-tune-up range. In export versions a tenth position provides no-tune-up 10 meter operation except that rf output may be broadly "peaked" for optimum efficiency across 28-29.7 MHz using the LOAD control.

Power Input: To 2.5 kW PEP/SSB, 1 kW average or carrier, CCS.

Typical Efficiency: 50-67% depending on load, frequency, drive, etc.

Drive Power: Nominal 60-80 watts carrier, 100-140 watts PEP.

Input & Output Impedances: Nominal 50 ohms resistive, unbalanced; load VSWR 2:1 or less manually-tuned, 1.5:1 or less for bandpass.

Distortion: Third order IM more than 30 dB below 1 kW PEP output.

Harmonics: Substantially better than FCC requirements; -55 dB typical.

Tube Complement: Two Eimac 8874 ceramic, grounded-grid triodes.

Cooling: Full-cabinet ducted forced air using cushion-mounted centrifugal blower.

ALC: Negative-going, adjustable threshold. (ALC is not normally required or used with solid state transceivers using positive ALC.)

HV/LV Tap Change: Panel-controlled internal relay is standard.

Protection: Primary fuses, plate relay, a-c and HV interlocks.

Primary Power: 220-250V/10A or 110-130V/20A, 50-60 Hz, 1 phase.

Size: 7.5" h x 17" w x 14.75" d (19 x 43 x 38 cm).

Weight: 65 lb (30 kg) net; 75 lb (34 kg) shipping in two cartons.

SECTION 2

INSTALLATION

1. Unpacking: Carefully remove amplifier and transformer from cartons; **SAVE PACKING MATERIAL FOR RE-USE -- SHIPMENT OF YOUR ALPHA IN OTHER THAN FACTORY PACKING MAY RESULT IN DAMAGE NOT COVERED UNDER WARRANTY.**

Inspect closely for evidence of shipping damage; if found, notify delivering carrier and seller at once. Complete warranty registration form and mail to ETO at once.

2. Transformer Installation: The cover of the amplifier is easily removed. Remove the three flat head Phillips screws from the front edge on top, two pan head screws from the rear flange of the top cover, and five pan head screws from each end of the cover -- then lift it carefully off. (If your amplifier has a flat head screw in the center of the top surface of the cover, REMOVE IT ONLY IF THE SLOTS ARE CLEAR AND THE SCREW UNPAINTED.)

Orient the transformer so that both multi-pin, molded plugs on the transformer harness point toward the front of the amplifier; move the corresponding mating connectors in the amplifier itself temporarily out of the way. Carefully lower the transformer into position so that the 1/4"-20 tapped mounting holes in its base line up with corresponding holes in the amplifier base plate. Install the 1/4"-20 bolts and washers provided, and tighten.

Check both pairs of connectors visually for proper mating orientation (avoid excessive harness bending or twisting, as it may cause damage to wires or connector pins) and mate them firmly, pushing until the integral latches engage.

3. Electrical Installation: The amplifier is normally shipped from the factory wired for 220-250V operation. If it is to be operated instead on 110-130V lines, change over the connections as described below before replacing the cabinet cover.

Changeover to 110-125V Operation - Locate the six-terminal barrier strip on the right side of the center chassis partition, above and to the left of the transformer. With short jumper wires only between lugs #2 and #3, the amplifier is connected for 240V power supply. Substituting instead a jumper between terminal #1 and #2, another between #3 and #4, and a third between #5 and #6, re-connects for 120V power source. (See sketches below.)



CONNECTIONS FOR 240V



CONNECTIONS FOR 120V

Power Cable Connection - The green wire of the amplifier power cable is a chassis safety ground, and must always (and only) be connected to the safety ground of the a-c mains -- NEVER to one of the "hot" power wires. The black and white wires are interchangeable and connect to the two "hot" service conductors.

4. Physical Location: Your ALPHA must be located so that intake of cool air through the rear panel, and exhaust of warm air through the top cover perforations, is not impeded in any way. A minimum of 4 to 6 inches of clearance should be allowed behind and above the amplifier for air circulation. Be careful not to block the top-cover exhaust openings with log books or equipment.

5. RF And Control Connections: Interconnection of the ALPHA for operation with any popular transceiver or exciter is extremely simple. Connect the rear panel jacks as follows:

RF INPUT - Use an appropriate plug and RG-58C/U or similar small 50 ohm coaxial cable to connect to transceiver or exciter "rf output" or "antenna" connector. KEEP CABLE AS SHORT AS POSSIBLE -- PREFERABLY NOT LONGER THAN 2½ TO 3 FEET.

RF OUTPUT - Use a standard PL-259 ("UHF" type) plug and RG-8A/U or similar coaxial cable (50 ohm) to connect to antenna system.

RELAY - Use a standard "phono-type" patch cable to connect this jack to transceiver or exciter contacts which are "open" on receive and "shorted" on transmit ("N.O." = "normally open"). Nearly all transceivers provide such contacts via either phono-type jacks or other accessory connector on the rear panel. (See AUX.)

NOTE: When the amplifier is OFF, or in the RECEIVE condition with no short across its RELAY line, the RF OUTPUT connector is internally connected directly to the RF INPUT, providing normal "transceive-type" antenna input to the receiver.

ALC - For use with tube-type transceivers having negative-going ALC systems with external input jacks, simply patch this jack to the mating one on the transceiver or exciter with a standard "phono"-type cable. Nearly all modern solid state (broadband) transceivers utilize positive-going internal ALC, with a detector at the rf output point. This internal system normally functions adequately to control SSB drive power to the amplifier; in fact, most such exciter/transceivers provide no external ALC input jack and it is entirely unnecessary to make any ALC connection.

6. Blower: The cooling blower is mounted on an "absorbent foam" cushioning pad which dramatically reduces transmission of mechanical noise. Two 10-32 Phillips head screws secure the blower motor to the amplifier rear panel for safe shipment, and must be removed for quietest operation (see Fig. 2). Remove both screws, as well as the rubber strips wedged between the rear panel and the blower motor, and save for future shipping. SERIOUS DAMAGE TO AMPLIFIER MAY RESULT IF AMPLIFIER IS SHIPPED WITHOUT THESE SCREWS AND RUBBER SHIMS PROPERLY RE-INSTALLED.

SECTION 3

OPERATION

1. Control Functions:

BAND - Selects the desired MANUAL or BANDPASS (no-tune-up) frequency range of the amplifier.

TUNE - Controls amplifier operating frequency when a MANUAL range is in use (chart of approximate starting settings follows).

LOAD - Controls amplifier loading when a MANUAL range is in use (chart of approximate settings follows). Allows broadly peaking 10 meter output 28-29.7 MHz on export models only.

PUSH BUTTONS -

ON: Depress momentarily to apply a-c power to amplifier, or to restore a-c power after an overload or fault trip-off.

OFF: Depress to remove a-c power from amplifier.

HV: Multimeter monitors high voltage; 3000 volts d-c full scale.

GRID: Multimeter monitors grid current; 150 mA full scale.

FWD: Multimeter monitors forward RF power; 2000 W full scale.

REFL: Multimeter monitors reflected RF power; 200 W full scale.

CW: Selects "low" plate voltage for CW/FSK/SSTV and other types of emission, including SSB, up to 1 KW d-c plate input.

SSB: Selects "high" plate voltage for 2+ KW PEP/SSB input.

OUT = STBY: When both the CW and SSB buttons are out, the amplifier is in STANDBY. Antenna relay is disabled, permitting straight-through operation of transceiver/exciter.

ALC - Rear panel screwdriver adjustment sets the drive level at which ALC voltage begins to go negative from zero. Use a small insulated screwdriver to avoid accidental shorting.

2. Tune-Up Procedure:

(a) GENERAL - The objective of "tune-up" is to adjust the amplifier (and its drive) so that it will deliver maximum available power output at the desired level of plate d-c power input, or at the available level of rf drive power, whichever is lower.

When the amplifier is adjusted for maximum attainable rf power output for a specific, fixed level of rf carrier drive power, it will deliver the best combination of efficiency and linearity possible at that drive level.

If operating drive power is greater than the tune-up level, flattopping, "splatter," and excessive grid current will result.

If drive power is less than the tune-up level, amplifier efficiency will be lower than normal (true of any linear).

It is therefore essential that drive power always be adjusted to a level suitable for the way in which the amplifier has been tuned up (whether manually or factory pre-set). Achievement of normal amplifier grid current is the most sensitive indication of proper drive level from the exciter.

IMPORTANT NOTE: Tune-up of an amplifier establishes a ratio of d-c plate voltage to d-c plate current (HV/I_p) for which optimum performance occurs. When your ALPHA is properly tuned up for maximum legal power input of 1 KW in the CW (low voltage) mode, approximate values are $HV = 1400V$ and $I_p = 0.7A$, so that power input $P_i = 1400 \times 0.7 = 980$ watts and $HV/I_p = 1400/0.7 = 2000$.

When you then switch to the SSB mode where $HV = 2100V$ approximately, your ALPHA is automatically adjusted optimally for plate current of 1.05 amperes ($HV/I_p = 2100/1.05 = 2000$). Since the panel meters are average-reading and cannot follow instantaneous plate current variations with SSB/voice modulation, the ALPHA 374A "PLATE CURRENT" meter will not indicate 1+ ampere when this desired level is reached on voice crests, but will typically swing to approximately 30-50% of the actual d-c plate current peak, indicating the highest average d-c plate current as defined by FCC.

One kilowatt of average d-c input, which is "maximum legal power" under FCC rules, corresponds to highest PLATE CURRENT meter swings of approximately 0.47 ampere if HV is simultaneously 2100V ($2100 \times 0.47 = 987$ watts average input). The actual peak or envelope-crest value of plate current under these conditions is approximately 0.9 to 1.2 ampere, yielding an actual PEP (peak envelope power) plate input of approximately $2100 \times (0.9 - 1.2) = 1890$ to 2520 watts ... roughly equivalent to the "rule-of-thumb" 2 KW PEP which is often (mistakenly) referred to as "maximum legal power."

Because grid current drops off rapidly with too-low drive power and soars abruptly with over-drive, the achievement of grid current in the normal range specified is an excellent indicator of proper drive level to an otherwise properly-adjusted linear.

- (b) INITIAL TURN-ON - Place amplifier in STANDBY (both the CW and SSB buttons out; both show black.)
- (1) Press HV button; multimeter scale is now 0-3000V d-c.
 - (2) Press ON button and release; MULTIMETER should promptly swing to 1.5 KV ± 100V (mid-scale) and panel meters should immediately illuminate pale red or amber. Blower should start immediately and exhaust air should be detectable flowing from top cover vents. IF ANY OF ABOVE DOES NOT OCCUR, PRESS OFF IMMEDIATELY AND CORRECT THE PROBLEM.
 - (3) When the tube warm-up delay is completed in 45 to 90 seconds, the meters will change to pale blue or green, indicating "ready to transmit."
- (c) BANDPASS (NO-TUNE-UP) OPERATION - Bandpass operation on the amateur 80-75 through 15 meter bands requires no adjustment of amplifier TUNE or LOAD controls. It is merely necessary to

- (1) Insure that VSWR of the connected load does not exceed approximately 1.5:1 (4% reflected power),
- (2) Select the desired BANDPASS position of the BAND switch.
- (3) Adjust exciter output power to the level which produces grid current multimeter indications of about 50-90 mA with steady carrier or maximum swings to about 50 mA with normal SSB/voice modulation.

LOAD VSWR: Use a reliable SWR bridge or RF wattmeter, such as the Drake WH7 or Bird 43, to determine that reflected power does not exceed 4% of forward power (SWR 1.5:1 or lower); leave amplifier in STANDBY and use only exciter power for this test.

If a good external RF meter is not available, the ALPHA's built-in rf wattmeter may be used. With amplifier in STANDBY and exciter operating, check that MULTIMETER needle deflection in REFL position to insure that it does not exceed the deflection in FWD; this indicates 10% or lower reflected power, or a VSWR under 2:1 which is safe for initial low-power adjustment.

Then proceed as outlined below, WITH THE FOLLOWING EXCEPTION: BEFORE switching the amplifier to the SSB mode or using it for an extended period in any mode, re-check the ratio of REFL to FWD power with the amplifier delivering approximately 500 watts FWD. A REFL indication of 20 watts or less (between the 0.1 and 0.3 marks on the red RF power scale) indicates VSWR of 1.5:1 or lower, which is safe for full power BANDPASS operation.

BAND SELECT: Set the BAND knob to the wide scale mark labeled 3.5, 7, 14, or 21 (MHz), as desired.

OPERATING ADJUSTMENT: Press amplifier CW button (LV), make certain that exciter rf output control is set to zero, and place exciter in the appropriate mode to deliver a steady carrier -- usually "CW" or "TUNE." Press amplifier GRID button.

Very slowly increase exciter carrier output from zero until either (a) PLATE CURRENT meter indicates 0.5 ampere (mid-scale) or (b) MULTIMETER indicates 50 mA GRID CURRENT (1/3 scale). Re-check load VSWR; FWD power will typically be at least 200 watts at 0.5 ampere plate current.

Continue to slowly increase drive until either amplifier PLATE CURRENT reaches 0.7 A or GRID current reaches 100 mA. Normal grid current is approximately 40-90 mA, however values up to 100 mA are acceptable. If GRID current reaches these limits before the desired value of PLATE CURRENT is achieved, drive power should not be increased further. In such a case, switching to MANUAL tune/load as described below will permit adjustment for full rated power operation.

At this point your ALPHA is properly set up for operation at approximately 1 KW input on CW, SSTV, or RTTY. For 1 KW PEP SSB input, simply adjust SSB drive level out of exciter to the point where amplifier GRID current meter swings are approximately 50 mA (1/3 scale) maximum.

HIGH POWER SSB ADJUSTMENT: After completion of adjustment for 1 KW operation as above, return exciter to "receive" or "stand-by" mode. Press amplifier SSB (HV) button and confirm that, with MULTIMETER HV button depressed, HV indication is 2.2-2.4 KV. Switch exciter to SSB transmit and slowly increase its SSB output level (while speaking normally into mike) until either (a) highest swings of the PLATE CURRENT meter reach approximately 0.45 ampere (corresponding to about 1000 watts average d-c plate input -- maximum FCC legal power), or the highest swings of the MULTIMETER with the GRID button depressed reach 50 mA. Greater GRID current swings indicate overdrive.

- (d) MANUAL TUNE-UP: INITIAL ADJUSTMENTS - Place amplifier in STAND-BY. Set controls to the preliminary points shown in Table I below, depending on the intended operating frequency.

TABLE I -- PRELIMINARY SETTINGS FOR INITIAL MANUAL TUNE-UP

<u>FREQ. MHZ</u>	<u>BAND</u>	<u>TUNE</u>	<u>LOAD</u>	<u>FREQ.</u>	<u>BAND</u>	<u>TUNE</u>	<u>LOAD</u>
1.8	1.8	58	43	7.1	7	50	45
2.0	1.8	41	53	14.15	14	16	75
3.6	3.5	75	20	21.20	21	10	82
3.9	3.5	62	35	28.7*	28*	N/A	80*

* Factory-provided 28 MHz coverage (semi no-tune-up) is included in export versions only.

- (1) Press CW button and switch exciter (with its rf output control set to zero) to CW or TUNE; the ALPHA panel meters should turn pale amber or red, indicating "transmit."
- (2) Very slowly increase exciter carrier output until amplifier PLATE CURRENT meter indicates half-scale -- 0.5 A. Press FWD and carefully adjust LOAD for maximum RF WATTS indication on the multimeter. Then adjust TUNE for maximum RF WATTS meter indication. Repeat the process of alternately peaking first LOAD, then TUNE, until no further increase in FWD rf power indication can be achieved.
- (3) Note the PLATE CURRENT meter reading; the desired value for one kilowatt d-c input is approximately 0.7 A (since $0.7 \text{ A} \times 1400 \text{ V} = 980 \text{ watts d-c input}$).
- (4) If the plate current in step (3) was less than 0.7 A, increase exciter carrier output slightly and repeat the LOAD-TUNE adjustment process of steps (2) and (3) again. If the plate current in step (3) was greater than 0.7 A, slightly decrease exciter output and repeat the process.
- (5) Continue the procedure of step (4) until, after the final LOAD-TUNE adjustments, the PLATE CURRENT is as desired.

OPERATING ADJUSTMENT: Your ALPHA is now correctly adjusted for operation at one kilowatt d-c input using the CW (LV) tap. Final set up and excitation adjustments should be performed exactly as described in the last two paragraphs of preceding section (c), above.

3. Operating Notes:

- (a) TUBES - The 8874 ceramic triodes are extremely rugged and normally operate with a large margin of safety. They will deliver outstanding service life IF not damaged by grossly excessive grid dissipation or airflow blockage (keep the intake and exhaust air vent areas clear!) Do not allow average plate current PER TUBE to exceed 0.35 amp for more than 15 seconds, nor EVER to exceed 0.5 amp. Do not allow grid current to ever exceed full scale (150 mA); normal operation requires only 40-90 mA.
- (b) INTERLOCKS - All ALPHA amplifiers are equipped with switches intended to shut off a-c power and short out the high voltage power supply when the cover is not securely fastened in place. These protective interlocks are provided to protect you against POTENTIALLY FATAL ELECTRIC SHOCK resulting from contact with lethal voltages inside the amplifier. The amplifier SHOULD NEVER BE ENERGIZED WITH THE COVER REMOVED except by thoroughly knowledgeable service personnel!
- (c) FUSES - Except in rare instances of component failure, the blowing of one or both primary line fuses indicates that the maximum safe average power capability of the amplifier has been substantially exceeded. USE ONLY 10A/250 VOLT RATED CERAMIC FUSES (except 15A for ALPHA 76CA and ALPHA 78); up to 20A ceramic fuses may be substituted for operation from 120V line only.**
- (d) PLATE OVERCURRENT RELAY - This relay serves primarily to de-energize primary circuits quickly in the event of a major HV fault or grossly excessive drive conditions. The relay should not be relied on to prevent damage due to either short- or long-term overdrive; that is the operator's responsibility. Should the overcurrent relay trip, thus removing a-c power from the amplifier, it is essential to determine and correct the cause before re-applying power by pressing the ON button.
- (e) MAINTENANCE AND TROUBLESHOOTING - Most problems and apparent failures with ALPHA amplifiers result from operators' failure to read and thoroughly understand the contents of the instruction manual -- as well as basic linear amplifier principles -- rather than from actual equipment defects.

The amplifier interior, particularly high voltage d-c areas of the power supply and rf compartment, should be cleaned frequently enough (with a soft brush and vacuum cleaner) to prevent visible accumulation of dust. If extremely dusty conditions prevail, it may be advisable to secure a thin plastic-foam air filter, of the type commonly used in window air conditioners, across the air intake perforations at the rear of the cabinet.

- ** Additional fuse information: The slow-blow fuse (F3) located just behind the front sub-panel on the partition is intended to protect the HV rectifiers and step-start resistors in the event of abnormal turn-on conditions or HV faults. DO NOT SUBSTITUTE a fuse of higher current rating under any conditions.

TABLE II -- TROUBLESHOOTING HINTS

<u>SYMPTOMS</u>	<u>POSSIBLE CAUSE/CURE</u>
1. Won't turn on; nothing happens when ON button pushed.	a) External a-c wire, fuse, or breaker open or missing. b) Cover a-c interlock open. c) Fuse F1 or F2 blown or missing.
2. Relay closes (and blower may start) but no HV or meter illumination at turn-on.	a) Step-start relay K2 not closing; possible blown fuse F3, defective +28V supply (D13-D-14 or C7?), or HV fault.
3. Blower starts, HV normal, but meters do not switch to green and amplifier will not switch to transmit.	a) Defective reed relay K6. b) Defective Q1, C8, or R29.
4. Grid meter "pins" at low drive levels.	a) R28 open or damaged.
5. Low grid current, excessive input VSWR (abnormal exciter loading), low rf output.	a) Bias zener D8 damaged or open. b) R28 damaged or open (but grid current will read very high).
6. Plate current flows in receive or STBY conditions. See also no. 9 below.	a) 8874 tube leak or short, cathode to grid or heater. b) D7 defective or damaged.
7. Low drive and output power; cannot drive exciter to normal input or output levels.	a) ALC sensitivity control R40 set improperly; unplug ALC to check. See note bottom of pg.
8. Flashover in RF compartment, usually between load capacitor plates.	a) Excessive load VSWR; mismatch or wrong antenna; defective rf cables or connectors. b) Insufficiently heavy loading and/or excessive drive power. c) Dirt or other contaminant in capacitor plates. d) If chronic, capacitor plates damaged by previous arcing.
9. Plate current flows in receive or STBY <u>and</u> cannot drive amplifier; abnormal exciter loading.	a) 8874 tube short, cathode-to-grid or cathode-to-heater.
10. Distorted SSB output signal; possibly severe TVI.	a) Excessive drive power and/or inadequately-heavy loading. b) Flashover of variable capacitor on voice peaks. c) Antenna or feedline arcing on peaks. d) RF feedback from antenna into exciter or microphone line.

NOTE: If exciter manufacturer does not provide instructions for adjustment of ALC, set pot R40 for desired amplifier plate current swings on peaks and adjust mike gain for degree of ALC action desired for normal exciter operation.

SECTION 4

THEORY OF OPERATION

1. RF Amplifier Section: Tubes V1 and V2 are parallel-connected in a grounded grid configuration. +28 volts of cathode bias is applied via R7 and L7 to cut off plate current during non-transmit periods; bias is reduced to the operating level of 5 volts when the antenna relay is actuated.

RF excitation is applied to the cathodes via an input matching network, including a broadband, toroidal ferrite transformer, which is carefully designed to present to the exciter a nominal 50 ohm load with linear characteristics. (Changing this input network may result in excessive input VSWR and/or distortion.)

The plate output network (switched by the four sections of S1A-S1D) is a full pi-L network. When a MANUAL tuning range is selected, the bandswitch connects the manual tune and load capacitors C16 and C17 to appropriate taps on the pi and L coils, resulting in a conventional pi-L. When one of the BANDPASS (no-tune-up) ranges is selected, additional variable and fixed capacitors (and additional inductor taps) provide the special values of C and L required for efficient no-tune-up operation across that particular amateur band, without the need for any TUNE or LOAD adjustments by the operator when changing bands.

In the 28 MHz position provided only on export models, the front panel LOAD control may be used to broadly "peak" output and efficiency at any point in the 28-29.7 MHz range. (TUNE has no effect.)

An RF directional wattmeter, consisting of L9 and associated components, senses forward and reflected power in the output line, for display by the MULTIMETER when the appropriate button is "in."

ALC rectifier C23-C24, D15, and associated components generate a negative-going ALC voltage when excitation voltage exceeds the bias threshold set by trimpot R40 (accessible from rear panel).

T/R relay K4 switches the antenna "straight through" to the exciter when the amplifier is in OFF, STBY, or receive conditions, permitting normal transceiver-only operation. K4 switches the ALPHA into transmit configuration when an external short is placed across RELAY jack J3.

2. Power Supply: T1 is a 1.5 KVA continuous service transformer which supplies all required a-c operating voltages for the amplifier.

High voltage d-c for the tube anodes is rectified by full wave bridge rectifier D1-D4, and filtered by a 30 mfd, 2.7 KV capacitor consisting of C1-C6. C1 through C6 are computer-grade units, factory matched and burned in to insure low ripple and long life.

Relay K3 selects high or low voltage taps from T1 and is controlled by front panel CW/SSB push button switches.

Cover interlock switch S4 prevents actuation of main power relay K1 unless the cover is secured in place. Additional operator protection is provided by safety "crowbar" S5, which shorts the high voltage supply and discharges the filters when the cover is opened.

D13-D14 and C7 provide +28 VDC for bias and control, including time delay and T/R circuits.

Dual primaries on T1 permit connection for either 117 V or 234 V nominal lines, as described in the INSTALLATION section of this manual. No wiring change is necessary for operation from U.S. standard 117-N-117 V or from typical overseas 234 V nominal without the "central" neutral ... two-wire systems. The third power cable (green) wire is a chassis safety ground.

3. Control and Metering Circuits: ON/OFF push buttons S2 control self-latching main power relay K1. R1 and R2 limit initial current in-rush to about 12 amperes maximum, and are shorted by relay K2 as soon as the HV filter capacitor is charged (a few milliseconds.) F3 protects the HV rectifiers and R1/R2 in the event of faults or errors which prevent K2 from closing normally.

The 8874 tubes are protected against operation during their required (60 second nominal) heater warm-up period by the time delay circuit consisting of Q1 and associated components. When C8 charges sufficiently to turn Q1 "on," K6 closes (via Q4 in some models), enabling the circuit of T/R relay K4. Until K6 closes, K4 cannot operate, thus insuring that cutoff bias is maintained on the tubes.

After delay relay K6 closes, an external short placed across the RELAY jack will actuate T/R relay K4 only if either the CW or the SSB button is depressed; if both are "out," the amplifier remains in standby mode. When K4 is actuated, tube bias is reduced to the 5.1 volt level established by zener D8. This level permits slight plate current flow when idling in the SSB (high voltage) condition; with the lower "CW" voltage idling plate current is close to cut-off.

Plate current is metered directly by M2. Grid current is measured across R28 in the grid return path, and high voltage is metered directly via precision multiplier resistors R13-R15

Substantially-excessive plate current (as evidenced by abnormal IR voltage drop across R6) actuates overcurrent relay K7, which trips out K1. Meter lamps I1 through I4, which are controlled by Q2 and Q3, illuminate the meters pale amber when K6 is open (during the warm-up delay) and when the RELAY line is shorted so that the amplifier is in the transmit condition. When the ALPHA is "timed in" but in STANDBY or receive mode, the meters illuminate green or blue, signifying "ready."

SECTION 5 -- ILLUSTRATIONS

FIGURE 1 - Top View Showing Major Component Locations

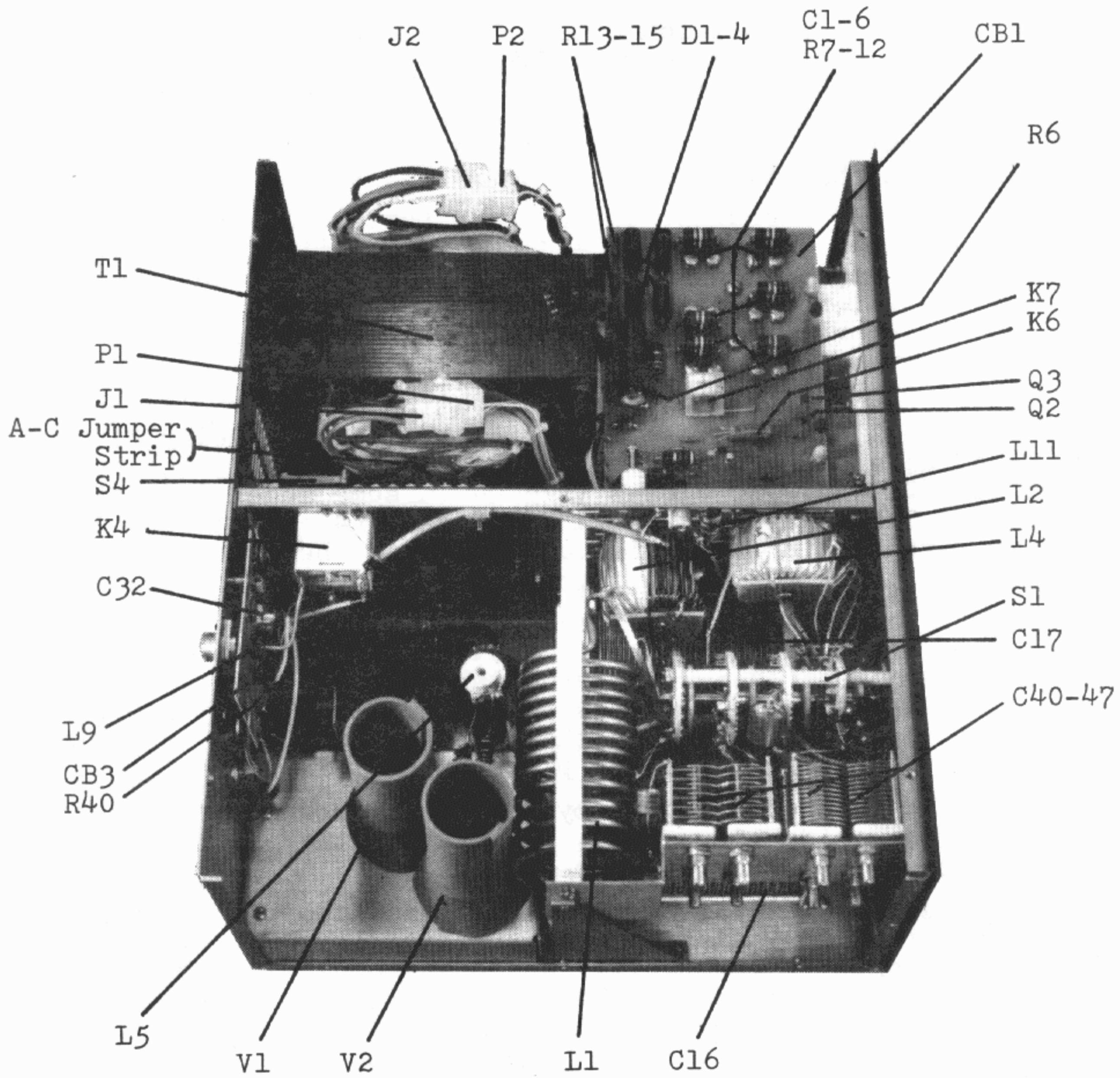

SECTION 5 -- ILLUSTRATIONS

FIGURE 2 - Rear View

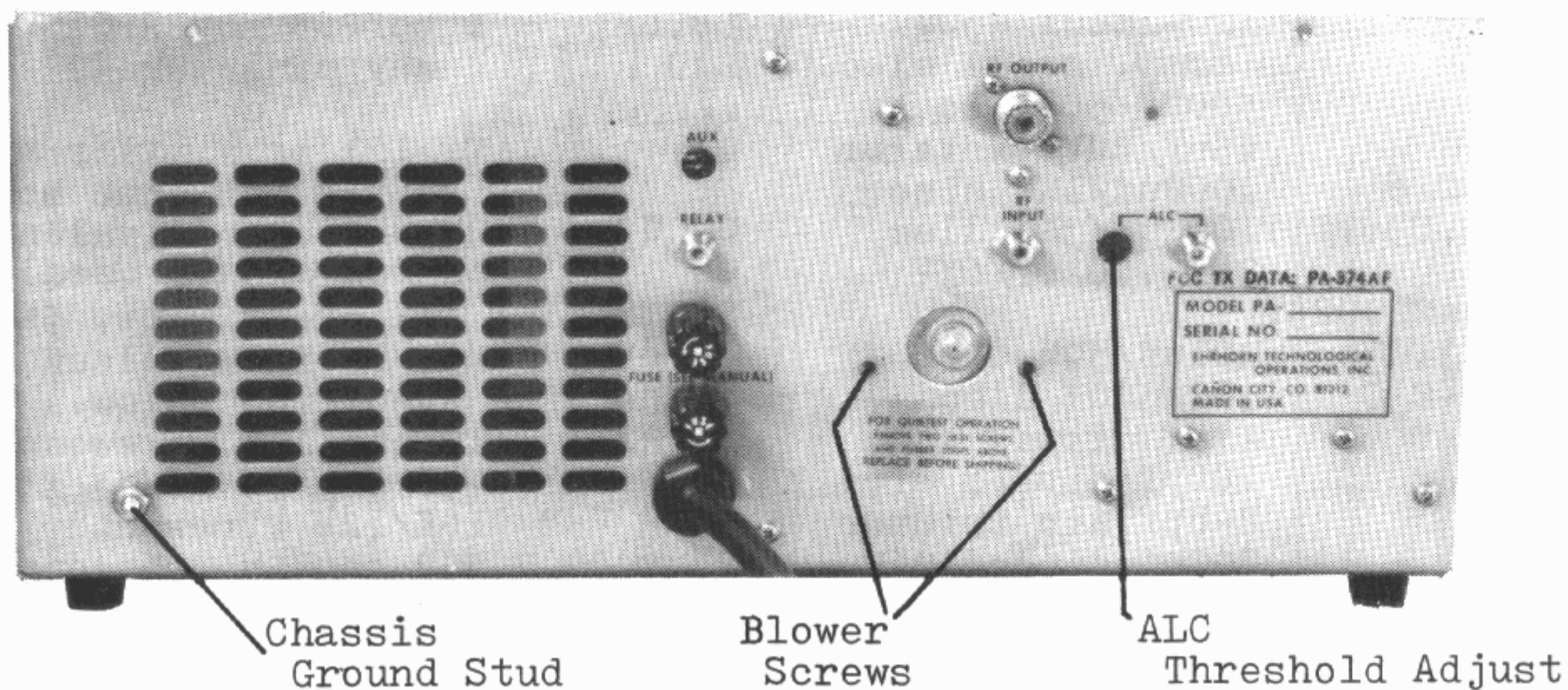
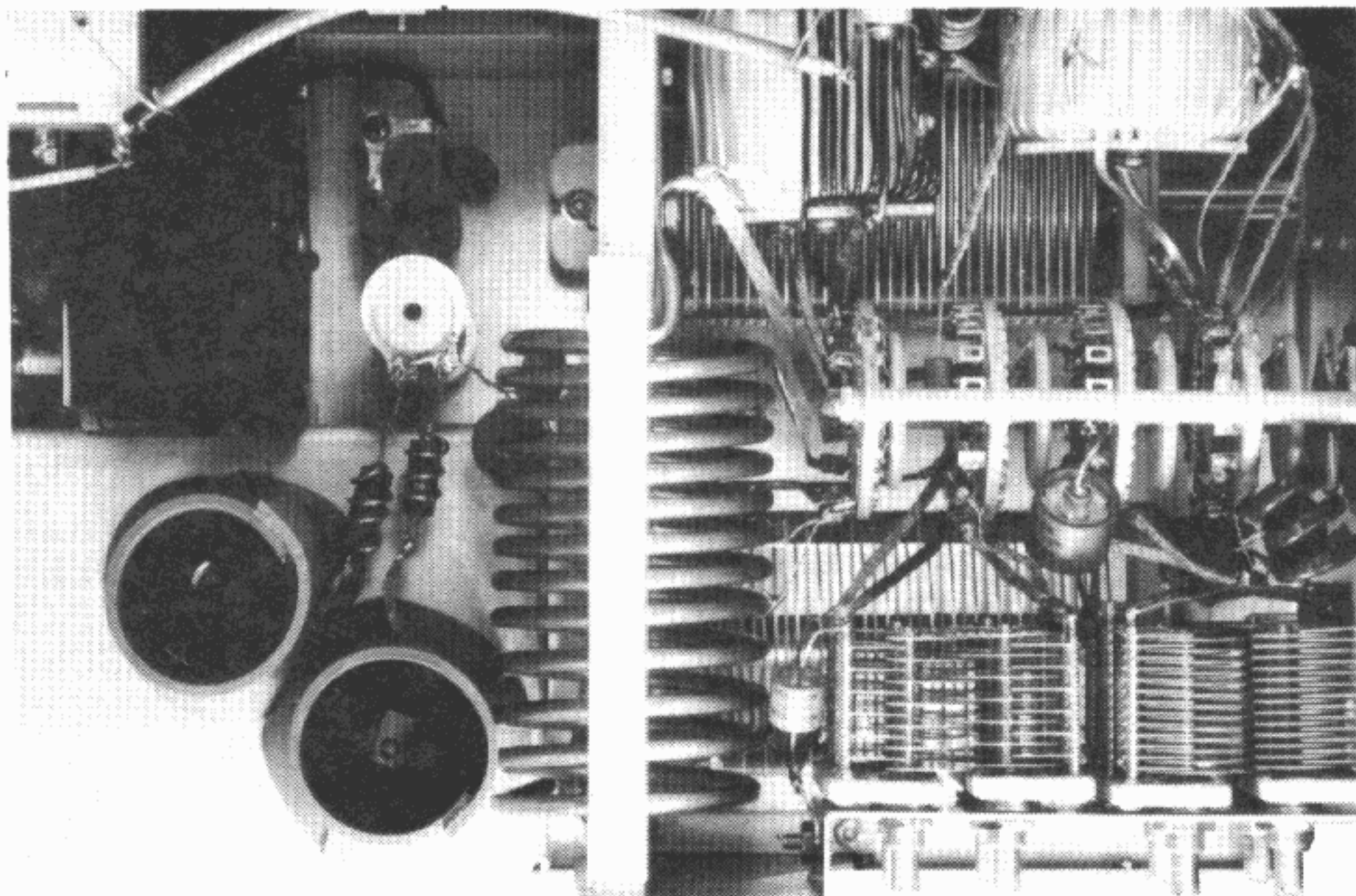
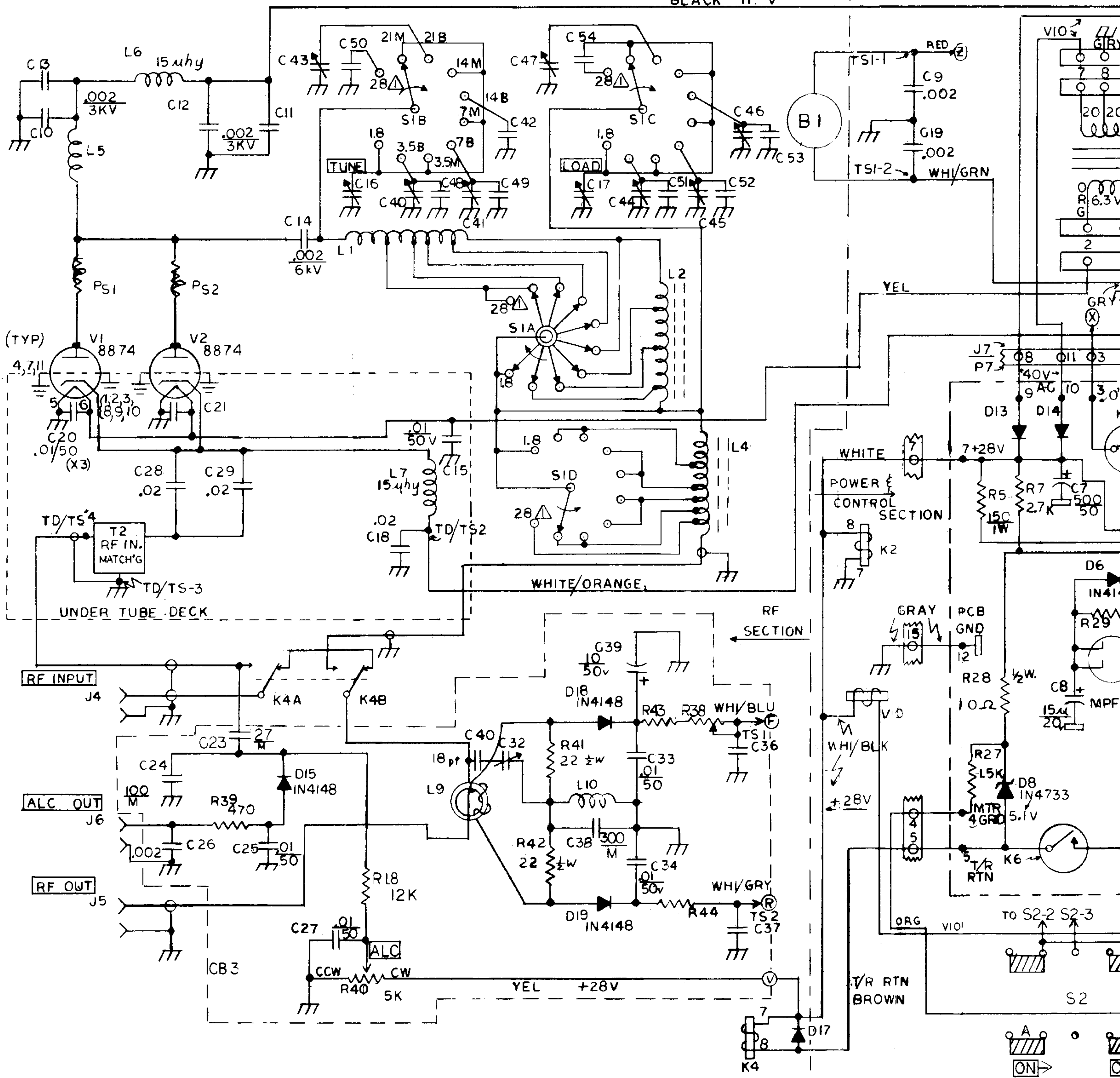

FIGURE 3 - Enlarged View of RF Output Network Area



SECTION 6 -- STANDARD ELECTRICAL PARTS

<u>SYMBOL</u>	<u>DESCRIPTION</u>	<u>SYMBOL</u>	<u>DESCRIPTION</u>
B1	Howard #3-90-8507	L5,L6,L7	15uhy/1A RFC
C1-C6	120-180uf/450V comp. grade elec.	L8,L11	1 to 2.5 mhy RFC
C7	500uf/50V elect.	L10	1 mhy miniature
C8	15uf/20V tantalum	Q1	MPF121 or similar MOSFET; 2N6027 PUT some models
C9,C19,C26	.002uf/1KV disc	Q2,Q3	2N5826 or equivalent
C10-C13,C36,C37	.002uf/3KV disc	Q4	2N5061 SCR (if used)
C14	2 x .002uf/6KV	RESISTORS: All are 1/4 watt, 5% carbon comp. or film unless otherwise specified below.	
C15,C20-22,C25, C27,C33,C34,C41	1.01uf/50V disc	R1,R2	10 ohm/12W wirewound
C18,C28-C30	.02/500V disc	R3	750 ohm/2W 10% comp.
C23	27pf dipped mica	R4	10K/12W wirewound
C24	100pf dipped mica	R5	150 ohm/1W 10% comp.
C32	2-8pf air trimmer	R6	25 ohm/25W wirewound
C38	300pf dipped S.M.	R7-R12	2 x 120K/2W 5% comp.
C39	10uf/50V elect.	R13-R15	1M/1% 3/4W precision
C40	18 pf/1 KV disc	R16	180K/1/4w
D1-D4	3KV PIV/.5A CCS, RCC 1733	R18	10-15K
D5	1N4746 (18V/1W)	R31	470 ohm/2W comp.
D6,D15,D18,D19	1N4148 or 1N914B	R32,R34	4.7K
D7	1N4722 or 1N5404	R36	3.3K/2W 10% comp.
D8	1N4733 (5.1V/1W)	R38,R40	5K trimpot, linear
D9	1N4757 (51V/1W)	R41,R42	22 ohm/1/2W 5% carbon
D10-D14,D17	1N4004 (400V/1A)	R43	
D20		R44	1.8K
F1, F2	10A/250V, type 3AB or ABC (78 & 76CA only, 15A)	R28	10 ohm/1/2 watt/5%
F3	1 1/2A slo-blo, type MDL or equiv.	S1	Centralab JV9034
I1-I4	Spcl, 28V lamp	S2,S3,S6	8 station special push button assembly
K1	DPST/120VAC, Guard- ian 1390-2C-120A	S4	Microswitch V3L-4-D8
K2	DPST/24VDC, Guard- ian 1395-2C-24D	V1,V2	Eimac type 8874
K3	HV relay, 24VDC, PB #PRD11DY0-24	ALL COMPONENTS SUBJECT TO CHANGE WITHOUT NOTICE. COMPONENTS NOT LISTED ARE SPECIALS AVAILABLE FROM ETO. SPECIFY MODEL AND SERIAL NUMBER OF AMPLIFIER PLUS CIRCUIT SYMBOL OR DESCRIPTION WHEN ORDERING REPLACEMENTS.	
K4	DPDT/10A		
K6	5 VDC coil, SPST N.O.		
K7	24 VDC coil, SPST N.O.		



NOTES:

- 1. 28 MHZ "E" SUFFIX ONLY
- 2.
- 3. ALL D's IN4004 UNLESS NOTED
- 4.



5. XFMR LEAD COLORS APPLY TO STD PA-76 XFMR ONLY; HIPERSIL XFMR WIRE COLORS VARY

7.

8. ALL RESISTORS 5 or 10% 1/4W UNLESS NOTED

FUNCTION & METER SWITCH ALL BUTTONS SHOWN "OUT"

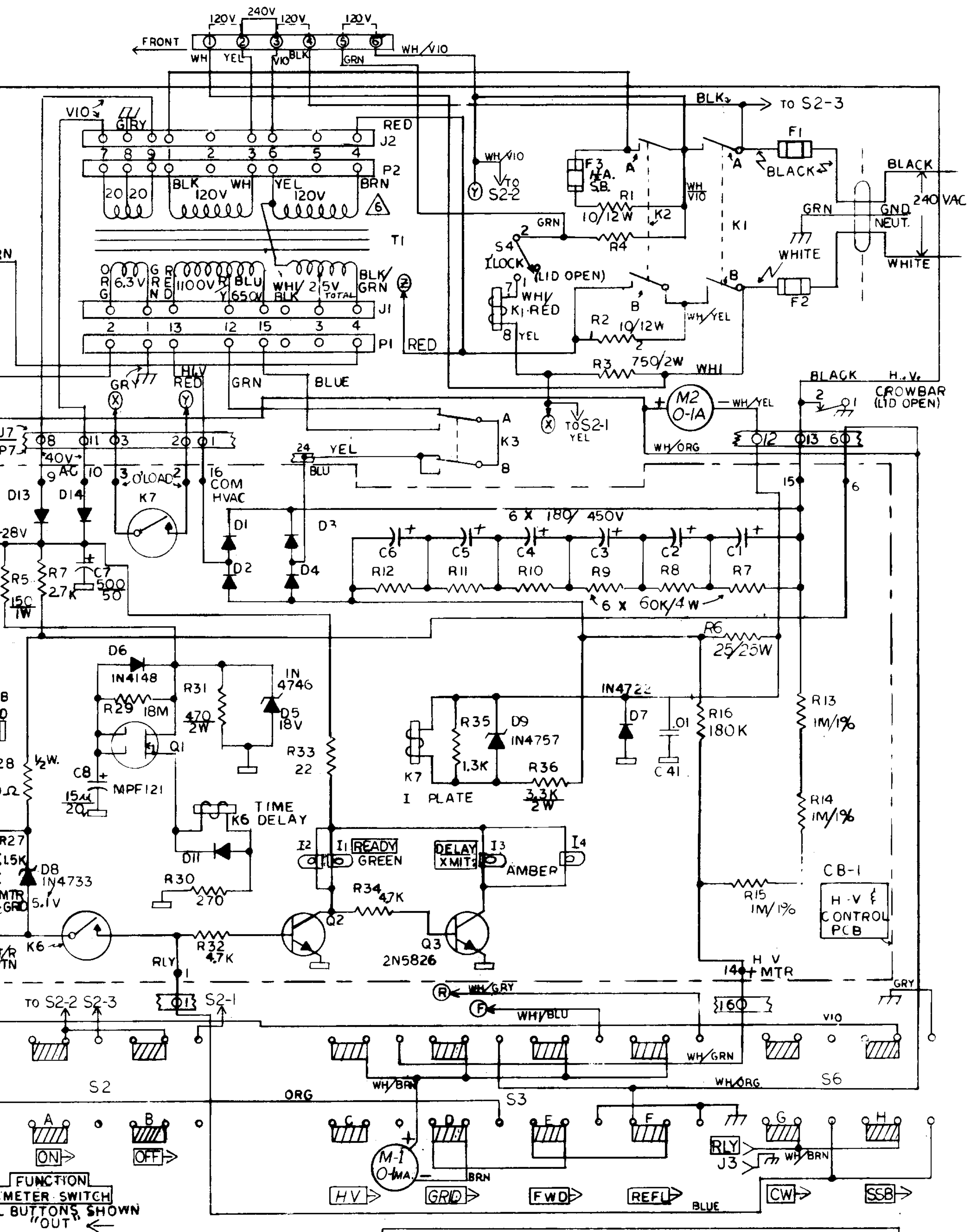

EHRHORN TECHNOLOGICAL OPERATIONS, INC.
 CAÑON CITY, CO. 81212

9/1/76
 4/14/78

Dwg. No.: SCHEMATIC
 More Information on Reverse

K4XL's **BAMA**

This manual is provided **FREE OF CHARGE** from the "BoatAnchor Manual Archive" as a service to the Boatanchor community.

It was uploaded by someone who wanted to help you repair and maintain your equipment.

If you paid anyone other than BAMA for this manual, you paid someone who is making a profit from the free labor of others without asking their permission.

You may pass on copies of this manual to anyone who needs it. But do it without charge.

Thousands of files are available without charge from BAMA. Visit us at <http://bama.sbc.edu>